

3.3 S-Bus Room Controllers configurable via PG5 and LON Room Controllers configurable via LNS tools

Dedicated room controller

Room controllers with a preconfigured regulation and control program which can be comprehensively parameterised via network communication and tailored to meet individual needs. Fully independent functionality is guaranteed even without a bus connection.

3.3.1 Project planning and engineering

In addition to the freely programmable controllers, the range of products for room-specific applications also includes dedicated SBC room controllers.

Main features

- ▶ **Application software included on delivery**
The room controllers can be parameterised via network communication and fully independent functionality is still guaranteed without a bus connection.
- ▶ **Efficient integration for suitable applications**
Use of HVAC applications in zones and room automation systems which adjust the I/O mix and integrated applications precisely to the specific application. As the room controllers are not fully programmable, unsuitable applications should be implemented with a solution which includes the "E-Line".
- ▶ **S-Bus room controllers are integrated into the Saia world**
The Saia FUPLA (FBoxes) enable engineering in the standard SBC environment and exploit the benefits of the Saia PG5 Controls Suite.

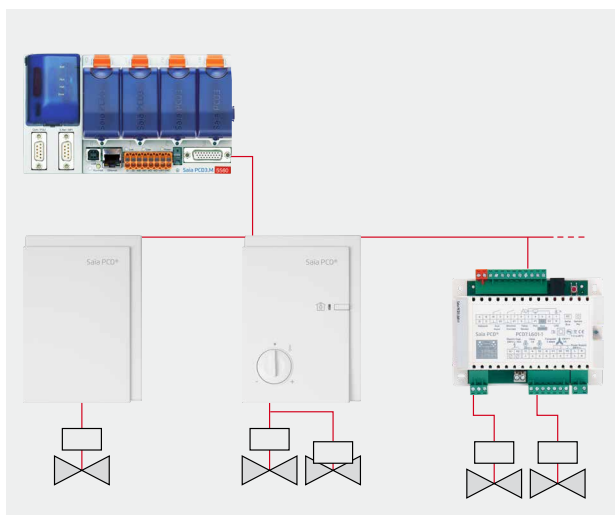

Parameterised via bus with Saia PG5 Controls Suite



Engineering information

Commissioning the SBC S-Bus and LON room controller

If the room controller is used as part of a SBC S-Bus network, addressing and configuration is carried out by the Saia PCD Master using the Saia PG5 Controls Suite. Practical FBoxes simplify commissioning.



The FBox setup and room controller service pin are used for the addressing process. It is recommended pre-addressing the room controller in the office.



If the room controller is used in an Lon network, the configuration is performed with a LonWORKS® tool such as the NL220 or LONMAKER®.

Integrating the SBC S-Bus room control system with S-Engineering using function modules (FBoxes)

- ▶ Programming and debugging environments are combined in the same tool.
- ▶ Complex user programs are created by simply placing and linking FBoxes with no extensive programming knowledge required.
- ▶ Online visualisation of the process values and online parameter adjustment directly at the FBoxes simplify the commissioning process.

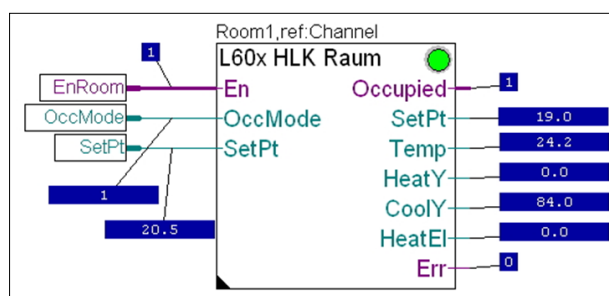

Online visualisation of the HVAC room FBox.

- ▶ The parameter windows of each FBox can be used to display online and directly adjust all setpoint values, actual values and statuses of the controller.
- ▶ Detailed, context-sensitive FBox information, clear descriptions and graphic representations in the function chart editor (FUPLA) provide clear, easy to read programs.
- ▶ It is possible to switch all control parameters to a control system using the PCD controller and thus reduce running costs.

Efficiency in project realisation

The FBoxes shorten the "Engineering time" and simplify the commissioning process, as the configuration data can be sent via the communication interface to up to 250 controllers in a single step. The automatic detection of the communication speed also simplifies the commissioning process.

Multiple application possibilities

Application programs for various types of systems are already pre-programmed in the controller and can be activated using the parameterisation.

Parameterisable application program

If the application supplied does not match the project requirements, the application program for different system types can be activated and parameterised via PG5 FBoxes or S-Web. The application software already contains several user programs for systems such as combined radiators/cooling ceiling systems.

Description	Online Value	Modify Value
RoomController PCD7_L60xV2HLK Konf		
Gruppenfunktion		
Von Stationsadresse	1	1
Bis Stationsadresse	250	250
Schreiben	...	ausführen
Stationsadresse in Bearbeitung	-1	
Einzelstation		
Stationsadresse	32	32
Lesen	OK	ausführen
Schreiben	...	ausführen
Raumbedieneinheit		
Anwendung		

Configurable using the PG5 Controls Suite

Description	Online Value	Modify Value
Hardware		
Regelparameter		
Basissollwert	22.0	19.0
Sollwert Minimum	12.0	15.0
Sollwert Maximum	35.0	29.0
Totband Komfort in °K	2.0	1.0
Totband StandBy in °K	4.0	4.0
Totband Reduziert in °K	6.0	10.0
Nachlauf Komfortbetrieb x10min	0	2
Kühlen		
Heizen		

The control parameters (PI) for the specific applications can be adjusted and optimised

Fully independent functionality guaranteed even with no bus connection

Once the application programs in the controller have been parameterised, it is possible to run a fully independent operation without a PCD.

The controller will therefore continue to operate uninterrupted even if communication with the Saia PCD automation station is disrupted. All the set configuration parameters are written to the EEPROM and remain stored there even with no operating voltage.

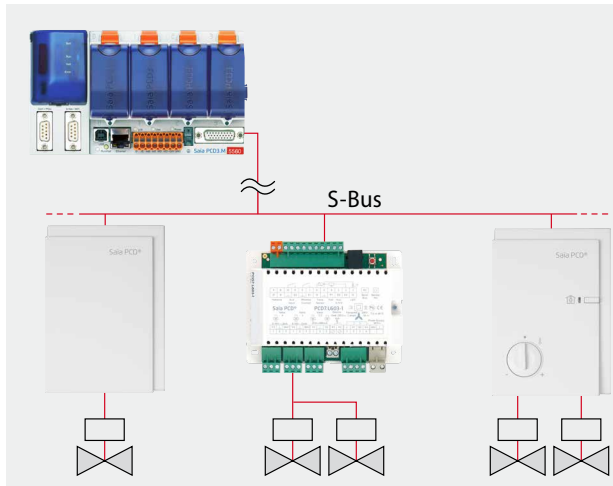

Functionality is also guaranteed in the event of a bus fault.

SBC S-Web

S-Web Editor macros simplify the efficient setup process of web-based commissioning, operation and service operating concepts.

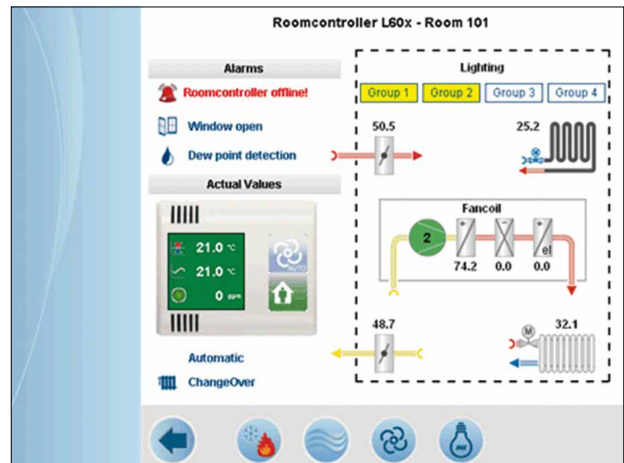

Visualisation and operation of the room parameters using the web server

This makes local operation using a PC workstation possible. The password protected control screens are loaded direct from the web server integrated in the automation station and displayed.

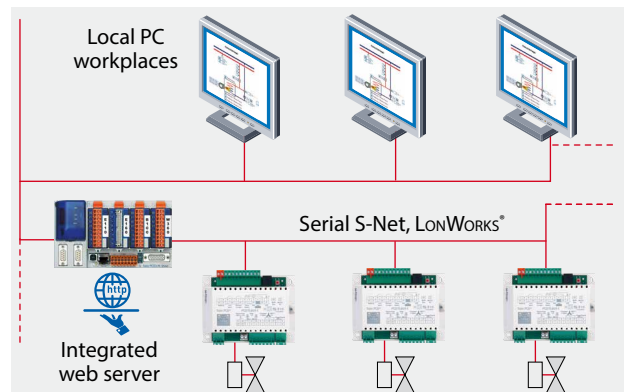

Local user prompts from PC workstation.

Project planning information

Bus terminating resistor and bus cable for serial S-Net (S-Bus/RS-485)

S-Bus cables must be installed as a line. Stub lines are not permitted and both ends of the cable must be terminated with a resistor (approx. 120 Ω) between the D and /D cables. The best signal quality is achieved using an active bus connection with a resistor to +5V and GND.

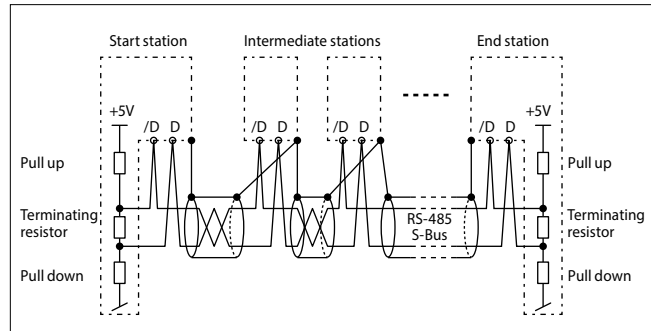

Schematic illustration of an S-Bus/ RS-485 bus

! With S-Bus controllers, the 111 configuration register can be used to activate the integrated active bus terminating resistor or an external PCD7.T161/2 termination box can be used.

Bus cable: A 2-strand twisted and shielded bus cable with cable strands of at least 0.5 mm² must be used.

Bus shielding: The shielding of each S-Bus segment may only be connected with the electrical system ground at one point.

To avoid problems with large potential differences between the room controllers, the shielding of the S-Bus cable should be connected with the GND of the room controller.

For more information, see S-Bus manual 26-739 (at www.sbc-support.com).

Maximum number of room controllers

The maximum number of room controllers that can be managed by a PCD system depends on the maximum electrical load of the serial S-Net, the bus system cycle time and the resources used by the functional objects.

PCD7.L79xN

Resources: approx. 2 kB (Program memory,) per controller, max. 40 registers per controller, max. 16 flags per controller

Bus cycle time per controller: approx. 15 ms

PCD7.L60x-1 (when using all FBoxes)

Resources: approx. 10 kB (Program memory,) per controller, max. 95 registers per controller, max. 36 flags per controller

Bus cycle time per controller: approx. 80 ms

At a communication speed of 38,400 baud, the communication time for a controller is approx. 15 ms or 80 ms. If the PCD program requires longer than 15 ms or 80 ms per PCD cycle, this value must be used as the basis of the calculation used to estimate the communication cycle. For additional information please refer to chapter 1.1.

Communication cycle = "15 ms or 80 ms per controller" × "Number of controllers".

Recommendation: max. 4 S-Bus interfaces with up to 25 room controllers per interface so that resources are sufficient in most cases and the communication cycle time remains < 2 seconds

Types of use and modes of operation

The function of the room controller is based on various types of use or modes of operation.

Each of the selectable modes of operation can be assigned different control parameters.

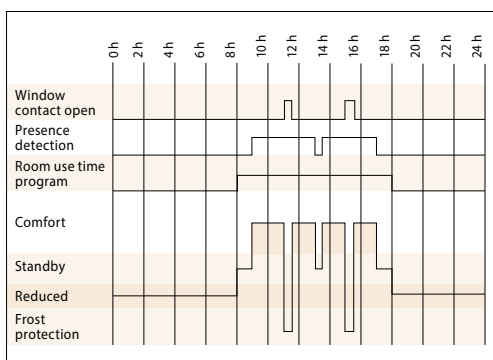

Example: Operating mode switchover

Safety mode/Frost protection

No heating or cooling energy is fed into the room. This state is desirable if a window is open. The room controller keeps the room temperature above the preset frost line of 8° C.



Non-use/reduced

Reduced operation mode which is used when the room is unoccupied for long periods. The specified setpoint value offset is not active in this operation mode.



Standby

The room is prepared for use but no presence has yet been registered in the room. As long as the room is not classified as occupied by the presence function, the room controller maintains the room temperature within the specified limits at the standby temperature.



Use/comfort

The room is used and should be brought to the comfort temperature.

This state can be reached by pressing the presence button, reacting to an external presence detector or a parameter on the network side.



Control parameters

The adjacent illustration depicts a selection of the most important adjustable control parameters of a PCD7.L60x-1 controller. Additional parameters such as reset times, threshold values, etc. can also be adjusted.

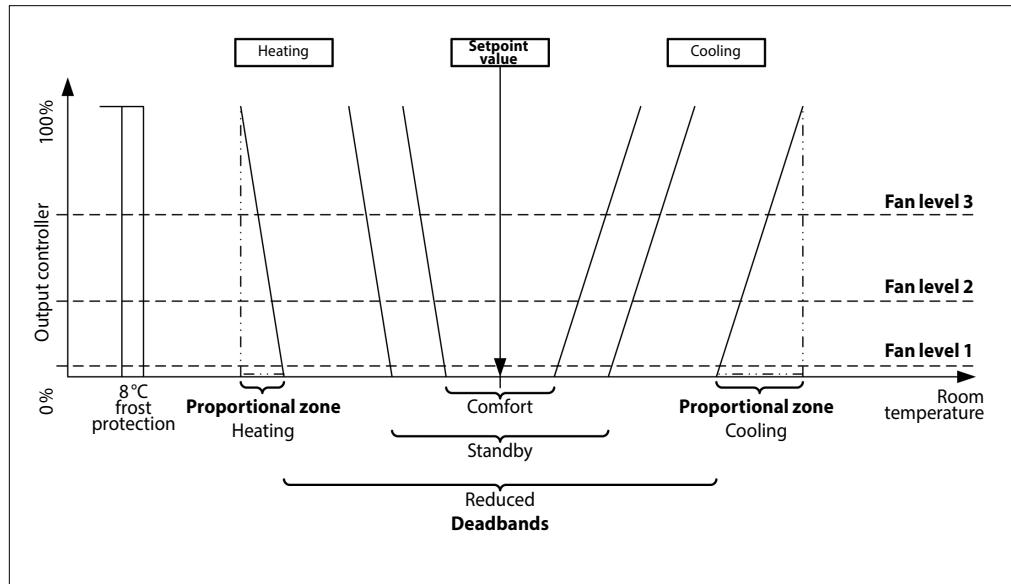

Example Selection of control parameters PCD7.L60x-1

Control devices and compact room controller installation information

- ▶ Do not install the control device /compact room controller near windows or doors due to potential draughts. The recommended position is on an opposite wall at a height of approx. 1.5 m.
- ▶ Do not install it near to heat sources such as heating systems, fridges, lights, etc. Avoid direct sunlight or direct light from bright lighting.
- ▶ Do not locate the control device /compact room controller in draughts produced by air conditioning and ventilation systems.

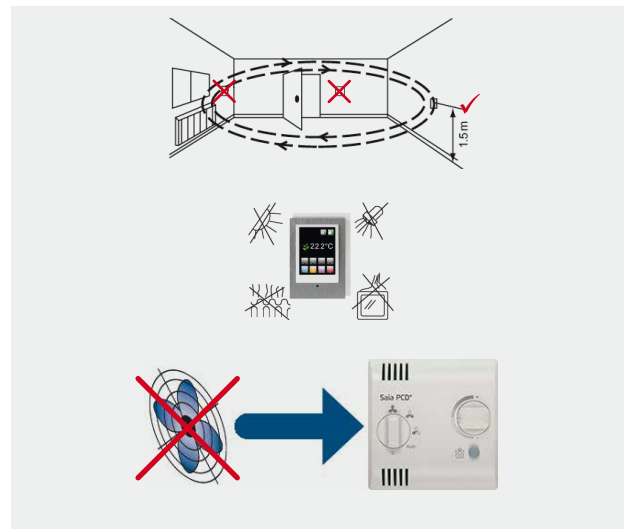

Planning reserves

If the predefined application is insufficient, free outputs can also be controlled for fully independent function directly via the Saia PCD program using the S-Bus.

The room controller can also be configured as a single RIO unit (Remote Input Output) by completely switching off the fully independent function. The Saia PCD station then controls all the inputs and outputs.

The resulting dependency of the availability of the S-Bus communication and the increase in the S-Bus cycle time should be taken into account during the planning stage.

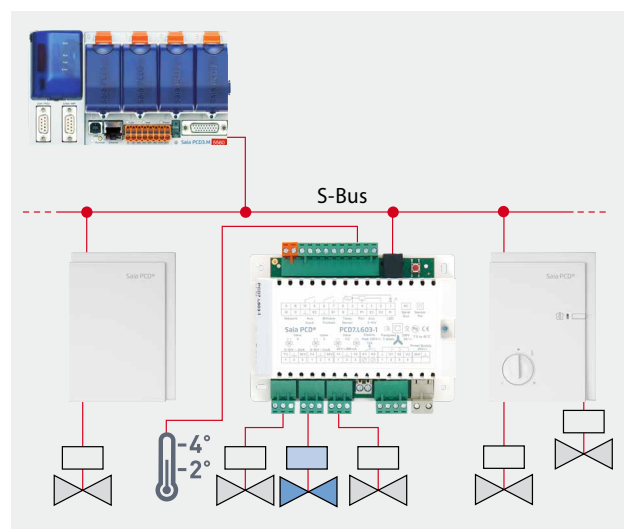

Control of free outputs via Saia PCD®

3.3.2 Compact room controller PCD7.L79xN

The series of compact room controllers is particularly suitable for simple systems which involve heating and/or cooling.

The PCD7.L79xN series room controllers include the control of presence and setpoint values, the room temperature sensor and the valve or flap control in a single housing. The pre-configured regulation and control program is part of the basic software and can be parameterised via the network communication and adjusted to the individual requirements.



Parameterised via bus with S-Engineering tools

Efficient installation

The compact room controller can be installed directly onto a wall or in a flush-mounted box. A junction box is not required, which also simplifies the installation process.

The plug-in housing (electronics) on the mounting plate with the terminals enables an easy exchange of the device with no complex and fault-prone rewiring required.

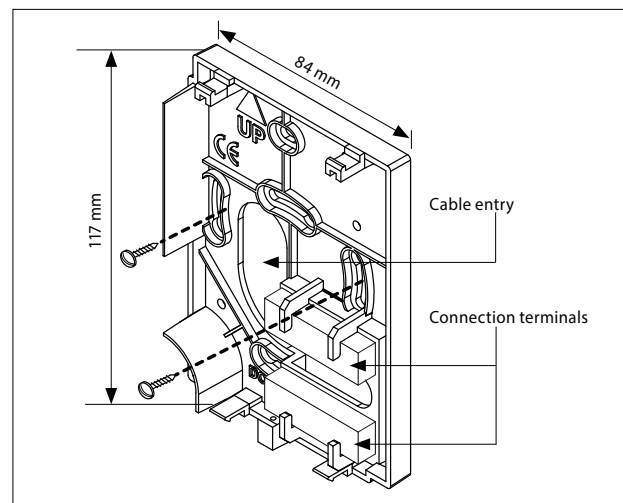



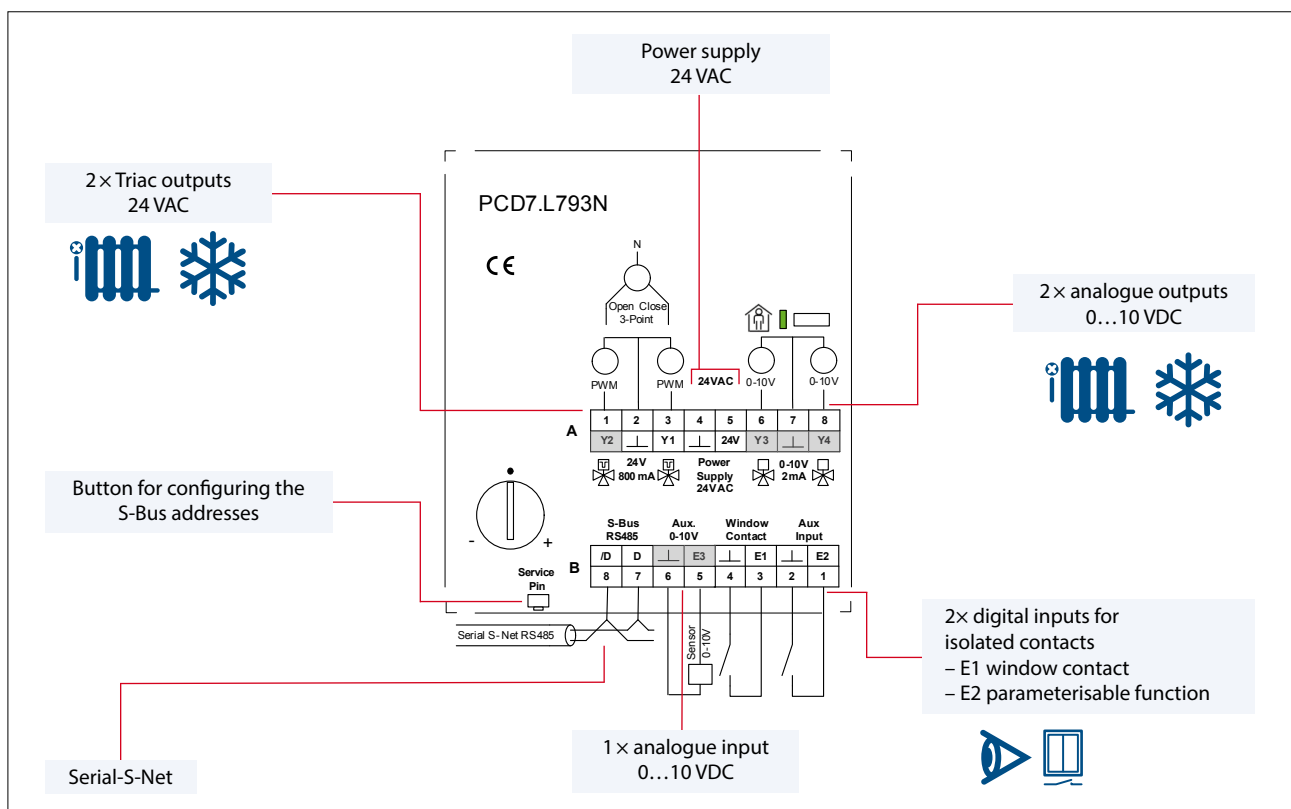

Mounting plate

Terminal assignment (example PCD7.L793N)



Product overview of the PCD7.L79xN series

	PCD7.L790N	PCD7.L791N	PCD7.L792N	PCD7.L793N
I/O				
Digital inputs	1× window contact and 1× multi-functional	1× window contact and 1× multi-functional	1× window contact and 1× multi-functional	1× window contact and 1× multi-functional
Digital outputs (PWM)	1× Triac 24 VAC	2× Triac 24 VAC	2× Triac 24 VAC	2× Triac 24 VAC
Analogue inputs	---	---	---	1× 0...10 VDC
Analogue outputs	---	---	---	2× 0...10 VDC
Integrated hardware				
Internal temperature sensor	NTC 10 kΩ	NTC 10 kΩ	NTC 10 kΩ	NTC 10 kΩ
Setpoint value setting	---	---	Yes	Yes
Presence button with LED	---	---	Yes	Yes
Actuated valve types and drives (Count independent)				
Digital output 24 VAC	1× thermal valve	2× thermal valve or 1× 3-point valve	2× thermal valve or 1× 3-point valve	2× thermal valve or 1× 3-point valve
Analogue output 0...10 VDC	---	---	---	2× 0...10 VDC valve or 1× 6-way valve or 1× VVS drive

Applications

2 pipes for heating, cooling or changeover	Yes	Yes	Yes	Yes
2 × 2 pipes for heating, cooling or changeover	---	Yes	Yes	Yes
4 pipes for heating and cooling	---	Yes	Yes	Yes
RIO	Yes	Yes	Yes	Yes

Application examples:

Radiator/cooling ceiling, underfloor heating/cooling ceiling combination (or as individual units), changeover operation (e.g. for cooling/heating ceiling)

General specifications

Power supply	24 VAC / requires an external electrical back-up fuse
Temperature detection internal sensor	NTC 10 kΩ / 0...40°C
Type of control	P or PI control
Communications interfaces	SBC S-Bus / RS-485 interface / data mode / 4,800, 9,600, 19,200, 38,400, 115,200 bit/s with automatic detection on restart. Bus terminating resistors are installed by the customer - integrated into the PCD7.L79xN and activated by the software.
Power consumption	1.5 W without actuators
TRIAC output specification	24 VAC / 800 mA maximum total current for both TRIAC
TRIAC direction of operation	Direction of action invertible / default setting: Normally open
Output specification 0...10 VDC	0...10 VDC / max. load 2 mA
Housing	Plastic, white, surface installation, protection class IP20
Dimensions	84 × 117 × 31 mm (W × H × D)
Temperature range	5...45°C, 80% r.H.

Manual and FBox library



<http://sbc.do/jkgyJL4>

3.3.3 Combinable room control system with S-Bus and LonWORKS® PCD7.L6xx

For room automation with combinable room control units and possibility of air quality control.

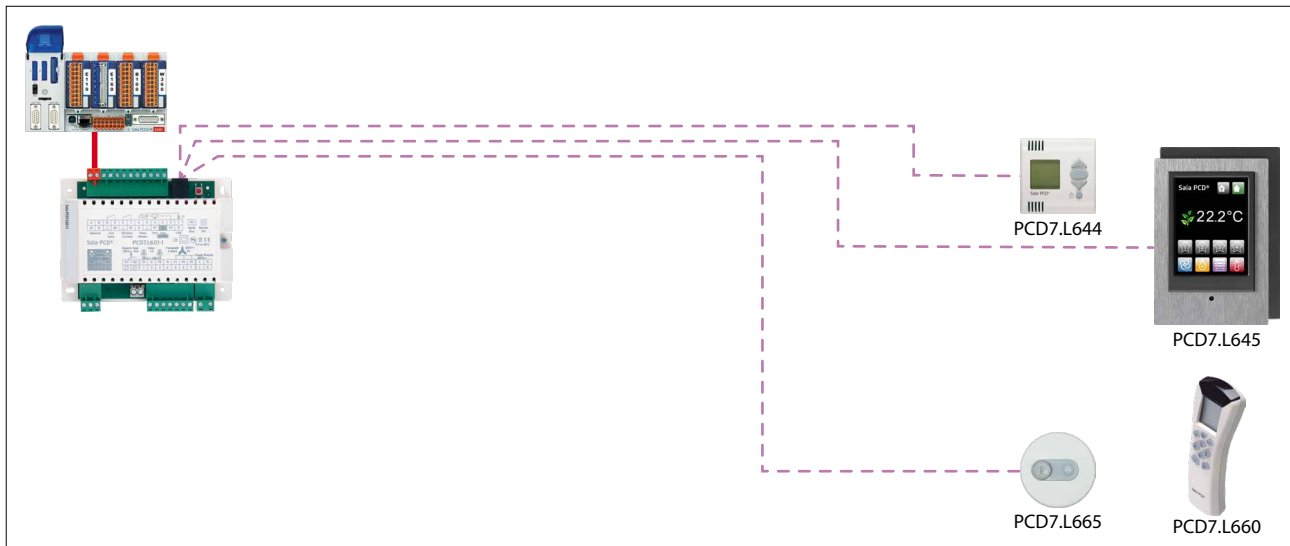









The PCD7.L6xx combinable room control system based on serial S-Net or LonWORKS® networks is used for HVAC applications primarily in fan coil devices, radiator/cooling ceiling combinations and variable air volume systems (VAV). The various room control unit options enable users to create individual operating concepts.

Features

- ▶ Comprehensive range of applications possible using parameterisable application programs
- ▶ Room controller for communication via serial S-Net or LonWORKS®
- ▶ Can be combined with various room control unit options
- ▶ The Lon room controllers fulfil the "Fan Coil Unit Object (8020)" application profile of LonMark®.

Product overview S-Bus and LonWorks® room controller

System catalogue
product families PCD7

	S-Bus				LonWorks®				
									
Power supply	230 VAC +10%/–15%	230 VAC +10%/–15%	24 VAC +10%/–10%	230 VAC +10%/–15%	230 VAC +10%/–15%	230 VAC +10%/–15%	230 VAC +10%/–15%	230 VAC +10%/–15%	230 VAC +10%/–15%
Inputs	L600-1	L601-1	L603-1	L604-1	L610	L611	L614*	L615*	L616*
Digital inputs	1x window contact and 1x multi-functional	1x window contact and 1x multi-functional	1x window contact and 1x multi-functional	1x window contact and 1x multi-functional	4x multi-functional	1x window contact and 1x multi-functional	4x multi-functional	4x multi-functional	4x multi-functional
Operating state response	Yes	Yes	Yes	Yes	Yes	Yes	Yes	---	Yes
Analogue inputs 0...10 VDC	---	1x 0...10 VDC	1x 0...10 VDC	1x 0...10 VDC	---	---	1x 0...10 VDC	2x 0...10 VDC	1x 0...10 VDC
Temperature sensor	1x NTC 10 kOhm	1x NTC 10 kOhm	1x NTC 10 kOhm	1x NTC 10 kOhm	1x NTC 10 kOhm	1x NTC 10 kOhm	1x NTC 10 kOhm	2x NTC 10 kOhm	1x NTC 10 kOhm
Setpoint value adjuster (10 kOhm potentiometer)	Yes	Yes	Yes	Yes	Yes	Yes	Yes	---	Yes
Outputs	L600-1	L601-1	L603-1	L604-1	L610	L611	L614*	L615*	L616*
Digital outputs TRIAC	2x 230 VAC (total max. 800 mA)	2x 230 VAC (total max. 800 mA)	2x 24 VAC (total max. 800 mA)	2x 24 VAC ¹⁾	2x 230 VAC (total max. 800 mA)	2x 230 VAC (total max. 800 mA)	2x 24 VAC ¹⁾	4x 230 VAC (total max. 800 mA)	2x 230 VAC (total max. 800 mA)
Relay outputs 3-level	1x 230 VAC (3 A)	1x 230 VAC (3 A)	1x 230 VAC (3 A)	1x 230 VAC (3 A)	1x 230 VAC (3 A)	1x 230 VAC (3 A)	1x 230 VAC (3 A)	---	1x 230 VAC (3 A)
Relay outputs 1-level	1x 230 VAC (10 A)	1x 230 VAC (10 A)	1x 230 VAC (10 A)	1x 230 VAC (10 A)	1x 230 VAC (10 A)	1x 230 VAC (10 A)	1x 230 VAC (10 A)	2x 230 VAC (10 A)	1x 230 VAC (10 A)
Analogue outputs (total max. 2 mA)	---	2x 0...10 VDC	2x 0...10 VDC	2x 0...10 VDC	---	2x 0...10 VDC	2x 0...10 VDC	2x 0...10 VDC	2x 0...10 VDC
Analogue outputs with additional 24 VAC power supply	---	---	Yes	Yes ¹⁾	---	---	Yes ¹⁾	---	---
Extension modules	L600-1	L601-1	L603-1	L604-1	L610	L611	L614*	L615*	L616*
Light modules	Yes	Yes	Yes	Yes	---	Ja ⁴⁾	---	Ja ²⁾	---
Shade modules	Yes	Yes	Yes	Yes	---	Ja ³⁾	---	---	---
Possible applications	L600-1	L601-1	L603-1	L604-1	L610	L611	L614*	L615*	L616*
Electrical heating only	Yes	Yes	Yes	Yes	Yes	Yes	Yes	Yes	Yes
2 pipes for heating or "changeover"	Yes	Yes	Yes	Yes	Yes	Yes	Yes	Yes	Yes
2 pipes for cooling or "changeover" with electric heating	Yes	Yes	Yes	Yes	Yes	Yes	Yes	Yes	Yes
4 pipes for heating and cooling	Yes	Yes	Yes	Yes	Yes	Yes	Yes	Yes	Yes
4 pipes for heating and cooling and electric heating (secondary)	Yes	Yes	Yes	Yes	Yes	Yes	Yes	Yes	Yes
4 pipes for heating and cooling and electric heating (primary)	---	---	---	---	Yes	Yes	Yes	Yes	v
2 x 2 pipes for heating, cooling or "changeover"	Yes	Yes	Yes	Yes	---	---	---	---	---
RIO	Yes	Yes	Yes	Yes	---	---	---	---	---
Direct control of outputs	---	---	---	---	Yes	---	Yes	---	Yes
Special functions	L600-1	L601-1	L603-1	L604-1	L610	L611	L614*	L615*	L616*
Air quality control (CO ₂)	---	Yes	Yes	Yes	---	---	Yes	---	Ja
Master / Slave	Yes	Yes	Yes	Yes	---	---	---	---	---

Controlled valves and required I/O

- Thermal valve:** 1 digital output (TRIAC PWM)
0...10 V valve: 1 analogue output (0...10 VDC)
3-point valve: 2 digital outputs (TRIAC PWM)
6-way valve: 1 analogue output (0...10 VDC) → can only be connected to one 6-way valve

Controlled drives and required I/O

- VAV-drive:** 1 analogue output (0...10 VDC)
3-stage fan: 1 relay output 3-stage
Fan with variable speed: 1 analogue output (0...10 VDC) → PCD7.L601-1...L604-1 and PCD7.L614...L616 devices only
Electric heating: 1 relay output 1-stage

Application examples: Fan coil, chilled beam, air quality control (combined with heating and second level cooling (radiator/cooling ceiling-, underfloor heating/cooling ceiling combination, changeover operation (e.g. for cooling/heating ceiling), VAV

¹⁾ PCD7.L6x4-1: The total power consumption of valves may not exceed max. 7W, output voltage: 24 VAC; –15% / +35%.

²⁾ Without automatic function

³⁾ Without blind slats rotation

⁴⁾ Without dimmers

*In preparation, see Chapter C1 "Product status"

Terminal assignment (example PCD7.L601-1)

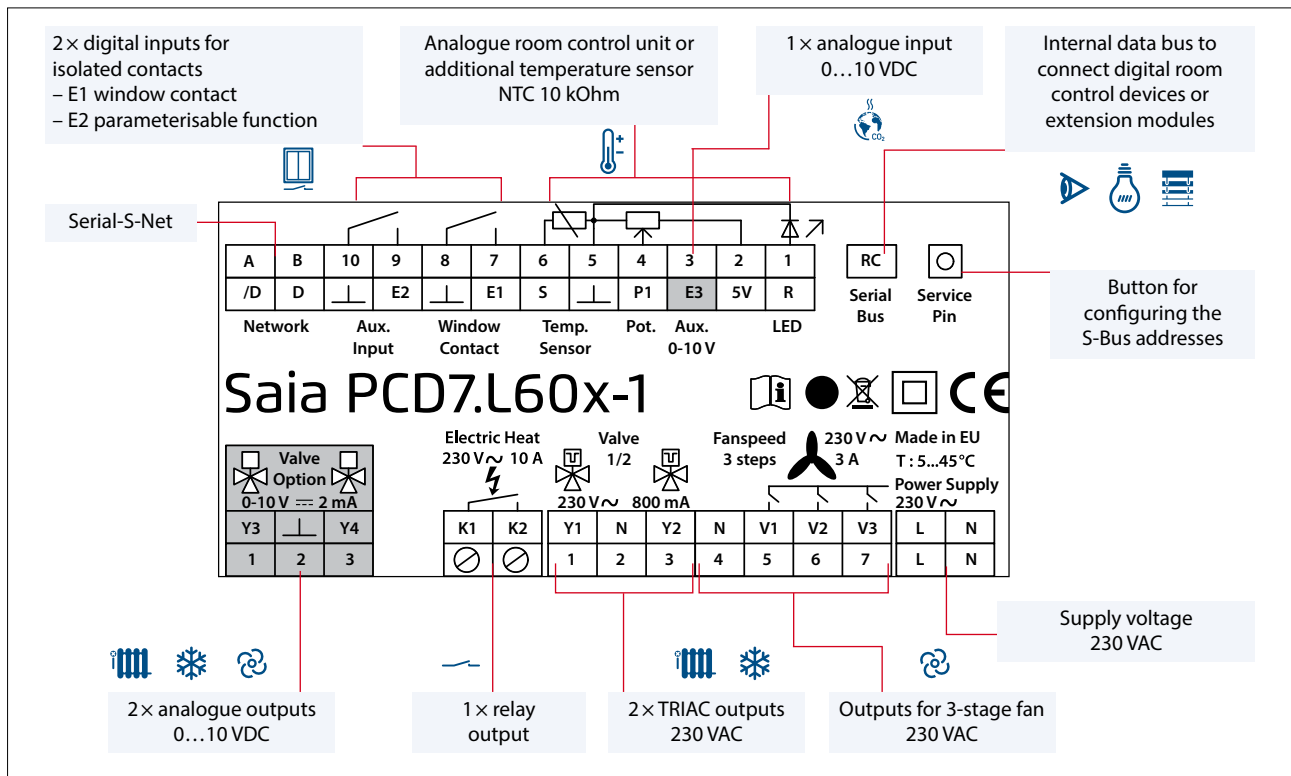

Technical Data

TRIAC output specification	10 mA...800 mA, maximum total current of both TRIACs
Current draw	Without actuator approx. 10 mA to 100 mA requires an external electrical back-up fuse
Protection	The module has to be installed in a locked box with aerations – minimum size: 240 × 145 × 100 mm
Dimensions W × H × D	132 × 95 × 45 mm
Temperature range	5...45°C, 80% RH

Communication with S-Bus

Interface	RS-485, max. cable length of bus cable depends on baud rate, under ideal conditions up to max. 1200 m
Transmission rate	4800, 9600, 19'200, 38'400, 115'200 bit/s with automatic detection on restart
Log	SBC S-Bus data mode (slave) Bus terminating resistors must be installed by the customer – with integrated L60x these can be activated by software.

Communication with LonWORKS®

Interface	FTT 10a
Transmission rate	78 kBit/s
Topology	Free topology max. 500 m, bus topology max. 2700 m
Number of Lon nodes	Max. 64 per segment, over 32,000 in one domain / in accordance with LonMARK® 8020 profile

Dimensions for

- ▶ PCD7.L60x-1
- ▶ PCD7.L61x

Mounting

- ▶ On 35 mm DIN rail
- ▶ Or with min. 2 × Ø 3 mm screws on an even surface

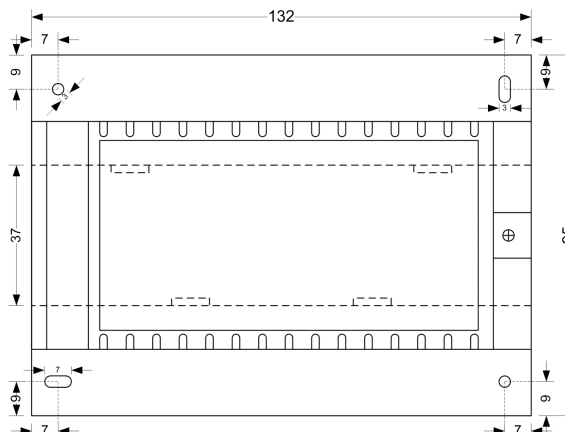

Manuals and
FBox library
<http://sbc.do/xmfBWij9>



3.3.4 Operation systems for combinable room control system PCD7.L6xx

Individual operating concepts can be implemented using the combination room control system:

- ▶ Simple connection via the internal RC-Bus to the RJ-9 connector
- ▶ LONWORKS® room control unit of external manufacturers via LON-BUS
- ▶ Web-based room control units via HTTP

Analogue room control units

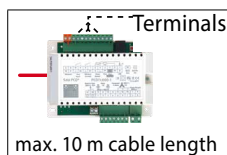

	PCD7. L630	PCD7. L631	PCD7. L632
Temperature sensor	NTC 10 kΩ		
Setpoint value adjuster	---	Poti 10 kΩ linear	
Presence sensor	---	---	Contact to GND
Response	---	---	LED

Temperature sensor	NTC 10 kΩ		
Setpoint value adjuster	---	Poti 10 kΩ linear	
Presence sensor	---	---	Contact to GND
Response	---	---	LED

Digital room devices

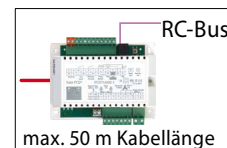

	PCD7. L640	PCD7. L641	PCD7. L642	PCD7. L644
Temperature sensor	•	•	•	•
Setpoint value adjuster	•	•	•	•
Presence sensor	---	•	•	•
Response	---	•	•	•
Fan control	---	---	•	•
Display menu for: HVAC functions	---	---	---	Parameterisable

Temperature sensor	•	•	•	•
Setpoint value adjuster	•	•	•	•
Presence sensor	---	•	•	•
Response	---	•	•	•
Fan control	---	---	•	•
Display menu for: HVAC functions	---	---	---	Parameterisable

Dimensions and installation options

PCD7.L63x, PCD7.L64x, PCD7.L651, PCD7.L663

Housing colour: RAL 9016

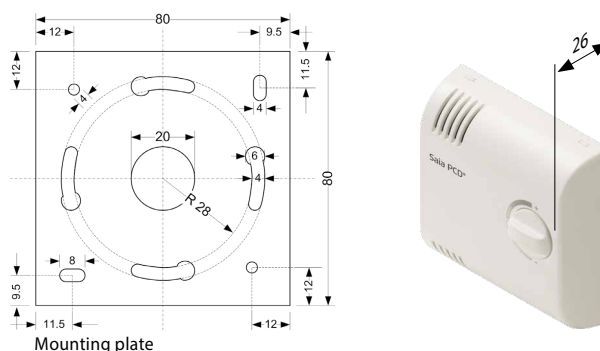

	PCD7.L645W/B	Dimensions and installation options
<p>3.2" touch screen room control unit PCD7. L645W/B</p> <p>max. 10 m cable length</p>		
Control for: setpoint value, fan and presence		
If, for example, a function is no longer to be displayed, access to specific menus can be prohibited with a password and hidden.		





- ▶ Automatic adjustment of the dimmable backlight depending on the actual brightness in the room ensures optimum reading comfort
- ▶ Screen standby timer for setting the time after which the screen will dim following the last action
- ▶ Star keys to define user settings and to call them up at a push of a button if required (up to 4 predefined scenarios can be saved)

PCD7.L645W: White housing (Pantone Q 716-3-5), 1 white and 1 aluminium front panel
 PCD7.L645B: Black housing (RAL 9011), 1 black and 1 aluminium front panel

Some projects require individual design in terms of shape and colour. The PCD7.L645W/B offers the option of replacing the front panel. The scale drawing for production on page 8-1 of the 27-605 manual is provided for manufacturing customised front panels.

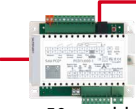

Portable room control units with display and function keys

Control devices	PCD7. L660	PCD7. L662		
				
Receivers	PCD7. L661	PCD7. L663	PCD7. L665*	
				
			max. 50 m cable length	
Wall mounted control device	Including for fixed installation		—	
Communication / IR (infrared)	Unidirectional		•	
Communication / radio			Bidirectional	
Temperature sensor	•	•	—	
Setpoint value adjustment	•	•	•	
Presence control	•	•	Movement sensor	
Fan control	•	•	•	
Brightness sensor	—		•	
Supply voltage control device	2 × AAA 1.5 V Micro		—	
Temperature range	+5...45°C, 80% r.H.			

EnOcean radio receiver PCD7.L651* for connecting Thermokon room control devices and EnOcean wireless switches



max. 50 m cable length

More detailed information on the compatibility of the EnOcean receivers can be found in the PCD7.L651 manual

Example of EnOcean wireless switch for controlling lights and Venetian blinds (compatible with various control programs of various manufacturers)



Example of EnOcean room control devices for controlling HVAC

Communicative room control units

Individual solutions using web-based room control units

System requirements:

- ▶ Room controller with communication to PCD via S-Net, LONWORKS® for HVAC control.
- ▶ PCD with corresponding interface and interface for connecting to the desired control device, e.g. web panel, PC, iPhone, etc.

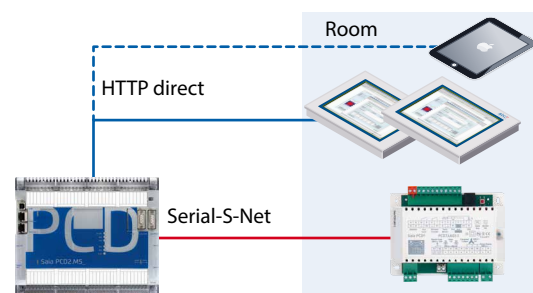
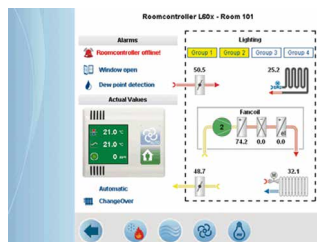

Direct connection of the room control units from the external supplier via LONWORKS®

System requirements:

- ▶ Room controller with LONWORKS® interface.
- ▶ For making additional connections to the automation station, the
 - PCD3.M
 - PCD2.M5
 - PCD1.M2 can be connected via the LON over IP or via an external FTT10/IP router..

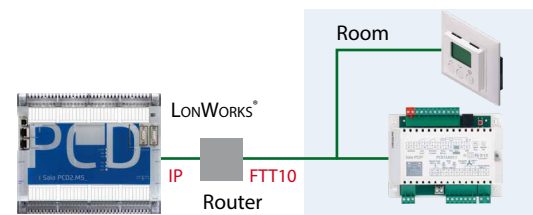

*In preparation, see Chapter C1 "Status: Product launch and availability"