

# ControlsNews

The customer magazine of Controls Division



saia-burgess

BTL Certificate for Saia®PCD3 with BACnet®

Telecommunication in automation

Further steps: IT & PLC = Saia®PCD

Better interfaces with Saia®Web-HMI



**Jürgen Lauber**  
Divisional Manager, Saia-Burgess Controls

## A good nose

Dear Reader

In the HMI field, what role does a nose play? None, really. When you do need a nose as a man machine interface, it's probably already too late, because the smell is accompanied by flames and billowing smoke. But in a figurative sense, a good nose also has special importance in automation. A company with a good nose for what will be the future developments, expectations and technologies of its markets stays one crucial step ahead of its competitors.

When we decided early on to equip all device series (even old ones) with Ethernet, we put our entrepreneurial nose for trends and developments to the test. Success has proved us right.

Once we had the scent, we immediately started tracking web technology. From 2001, all new controller CPUs were equipped with an integral web server as standard, and at no extra cost. Now, more than half our active customers make use of this ability to create control, visualization and service functions on a standard Windows® PC, via the web-browser.

Now we have picked up a new scent. The display quality of mobile phones with Windows® is undoubtedly raising requirements and expectations at the field level of automation. For small, low-cost panels, the future will also lie in the simplest networkability and a more comfortable screen design.

We are confident that the Saia®Web-Panels with micro-browser technology presented in this magazine will provide further proof of our good nose. We develop new products, not me-too products.

However, this path of technical entrepreneurship is not always the easiest one – neither for ourselves, nor for the first users. The first ones to use a new technology and translate it into concrete solutions are making an investment to safeguard their future. We invite you to follow our example. ■

### The Cover

The eyes, ears, fingers and the mouth are the human interfaces to the automation world. The nose does not belong in this category, but it's never the less important in automation.



Saia-Burgess Controls Ltd  
Bahnhofstrasse 18  
CH-3280 Murten  
Switzerland

T +41 26 672 71 11  
F +41 26 672 74 99

www.start-controls.com  
pcd@saia-burgess.com

# Contents

## BASIC PRODUCTS

Saia® Web-HMI – See me, feel me, touch me...	2
Saia® S-Web-Editor version 5.10	4
New flash memory modules	6
Product Preview 2007	7
Saia®PCD3.Compact	7
Saia®PCD2 New	7
News	7
Windows® and PLC technology, the winning alliance	8
Energy meters: on the mains and networkable	10

## INFRASTRUCTURE AUTOMATION Saia®DDC Plus

Application light/shade	11
Saia®PCD3 controller gets BTL logo	12
Easier integration, thanks to BACnet® in Den Helder (NL)	12
Flexible BACnet® topologies with Saia®PCD3	13
Visi.Plus version 1.4	14
Saia®DDC.Plus system catalogue	14

## MACHINE CONTROL

Yes, you CAN!	15
Saia®F-Box-Builder editor function	16

## TECHNICAL SUPPORT

FAQ Manager	17
News	17
New PC software	19
New firmware	19
New documents since Controls News 8	19

## TECHNOLOGY AND TRENDS

Telecommunication in automation	20
---------------------------------	----

## DIVISION-INFO AND REFERENCE APPLICATION

Own production area for control panels	22
New Internet presence www.start-controls.com	22
China and Controls?	23
Freedom of the Seas, the world biggest cruise ship with Saia®PCD	23

## LOCAL NEWS 25/26



New Saia®PCD Web-Panel portfolio 2



Windows®-compatible PLC technology 8



BTL certificate for Saia®PCD3 with BACnet® 12



Saia®PCD with CAN 15



New Internet presence for S-B Controls 22

## See me, feel me, touch me....

Like "Tommy" in The Who's monumental rock opera, users of the new Saia®PCD Web-Panels will also experience the intensity of new senses ... this time in automation. These web-based HMI devices are designed to suit small or complex applications, and they make seeing, feeling and touching seamlessly possible.



Saia NT-OS



Windows CE

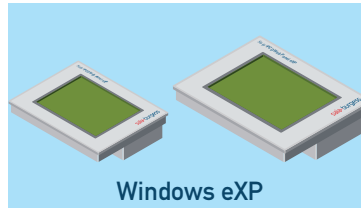

Windows eXP



Windows XP

### Saia® Web-HMI

In infrastructure and factory automation, a requirement for lean, easy-to-understand visualization can increasingly be assumed.

Even more than machine manufacturers, system integrators are confronted by a challenge: how to translate into reality the widely claimed but often misapplied concept of intuitive operability. Rather than creating unique visualization approaches and optimizing them for an application, system integrators must satisfy every day anew the widely differing mentalities of end customers, and transpose them into individual cases.

For better or worse, it seems that there is probably no more subjective concept in the otherwise rational world of automation than "intuitive operability".

As a producer of HMI solutions, Saia-Burgess Controls provides the fundamentals.

It is not just the design capabilities of an HMI toolbox that make for successful customer solutions. Instead, many aspects have to be taken into consideration

before one can offer an attractive product that is both sustainable and repeatable.

We have studied some of these aspects on your behalf...

#### See me...

First impressions of an HMI solution are often crucial in deciding basic attitudes to our customers' products. The HMI portfolio of Saia-Burgess Controls presents itself as an elegant, neutral framework for the application. During development, the guiding principle of its design and technology could have been summed up in four words: reduce to the max.

We were careful to ensure continuity of look and application neutrality: from the slim, local operator station to the remote supervision device; from colour specification to form and lines: design defines function – especially at first sight.

Would you, as an OEM, like to be sure that your own corporate identity is being used on-site? Contact us ...

#### Feel me...

Compactness is sought after, especially when screens are small. Industrial quality, fanless, hard-diskless systems, a lack of moving parts to produce little heat, and a mechanically sophisticated housing...

HMI solutions from Saia-Burgess Controls – from the 3.5" MicroBrowser panel to the 15" eXP panel – feel compact, solid and robust.

#### Touch me...

Function keys or TouchScreen – what do you prefer? Both?

Small screens often need function keys for frequently used functions. However, even compact HMI devices should not be deprived of the quality seal of TouchScreen operation, which is both convenient and easy for users to understand.

HMI devices from Saia-Burgess Controls offer function keys as standard on small and medium-sized screens, or as an option with the TouchScreen. CE and eXP devices can be loaded at a touch of the screen – touch me!

#### ... scale me!

Seamless HMI solutions from our company – whether they are handheld PDAs with small, 3.5" screens, or Windows-based HMI panels – all use the same project formats and can be selected as preferred. The visualization project is supplied to the PCD on demand by the web server. Display takes place locally on the panel, independently of the operating system. Saia®NT.OS, Windows® Mobile, Windows® CE and Embedded Windows® XP allow you to use additional – possibly external – resources on site.

Network and domain connection? Wireless LAN connection? You want maintenance and service manuals as online PDF files – i.e. provided by the controller as and when required? Application videos? Display on different HMI devices simultaneously? Different information contents from one controller at the same time?

You have a wide variety of requirements for different applications, and for different versions of the same application, but for your entire portfolio?

Saia-Burgess Controls HMI solutions are continuously scaleable and expandable; combinable and interchangeable.

### Anti-collision system for cranes

With the help of Saia® micro-browser panels, AGS/Fitec offers complete solutions for visualizing, safeguarding and controlling the interference zones and blocked ranges of all types of crane.

This clear, intuitive display, which uses the colour touch-screen of a micro-browser, shows a dynamic synopsis of the crane and, for supervision, an overview of all individual cranes. More than 700 parameters are configured from the panel.



**... tool me!**

Continuity awaits the user even when editing the solution. With the Saia®S-Web editor (now available in version 5.10) visuals can be edited quickly and interactively, and will remain compatible with all Saia®S-Web HMI devices. Programming knowledge of HTML or Java is not required.

You create your display interactively on the screen in WYSIWYG format. Whether for operation, visualization, management, or general oversight – just create the display page you want. Once edited, this page can be displayed on all devices.

**... connect me!**

Connections are established via Ethernet, USB or a serial port – finished!

**... operate me!**

Visualization on Saia®S-Web devices requires no special configuration, no downloading of the project to the target device, and therefore no sharing of source files either.

Your project remains protected. During power-up and the establishment of a connection, the PCD controller first sends the Saia® IMaster applet to any unrecognized visualization device. This applet contains all the tools needed for display. Your newly connected service laptop therefore automatically becomes a visualization station and control panel

for the application. Display and operability are uniformly the same.

**... save me!**

Within the visualization project, the customer decides who receives what access or viewing rights. Through password levels and the local Ethernet infrastructure, either local or Internet-connected sub-networks can be used. The PCD stores and manages these passwords and access levels for the protection of the application.

**... choose me!**

Since HMIs may be used for application control, visualization or management, the type of solution is determined by requirements. Micro-browser panels based on Saia's own operating system (Saia®NT.OS) are low-cost, reliable panels for local operation. As the foundation of our HMI range, they cover single panel/multiple machine applications, and even multiple panel/single machine applications.

Larger screens and display capabilities, or the integration of existing files and documents, are supported by Saia®CE or eXP panels. They provide users with access to the Windows environment, allowing networking and integration within Windows infrastructures. The visualization project remains the same; the choice of operating system is determined by the level of complexity.

**Visualization and monitoring of drying systems for wood**

SECEA is an Italian company with a reputation as a world leader in the production of drying systems for wood. Web-based visualization is used for displaying, monitoring and operating the drying process. The panel used is the Saia®Micro-Browser. Comfort Line colour panel with a personalized front cover-sheet. Function keys are used for navigation.



**Control and monitoring of automatic warehouse systems**

Kardex is one of the world's leading manufacturers of automatic warehouse systems. Depending on the type of machine, panels used for visualization and operation range from text-based Saia® panels (for simple applications) to micro-browser touch-panels (for more demanding ones) and Saia®CE panels (for the most demanding applications). Scalable and expandable service tools, developed by Saia-Burgess Controls to match the PCD and the web-based HMI solution, are used by non-programmers at the customer's location to maintain, back-up, administer and update controller programs.



**... read me!**

The use of Unicode and international character sets also allows Chinese, Arabic and Cyrillic text to be displayed and used in the project. The "see me" effect comes alive and works best when a local application can be seen to switch to the local language during run-time.





**... inform me!**

Would you like to know more about seamless HMIs? Go to our website [www.start-controls.com](http://www.start-controls.com) ■

# Saia® S-Web editor version 5.10

The first version (4.01.00) was launched in early 2005. At the beginning of November 2006, the 4th edition of the S-Web editor, version 5.10.00, will be released. Alongside numerous small additions, alarm management is one of the most important new functions.



-  Graphical Java objects
-  Macro management
-  Trend curves
-  Alarm management
-  Language management



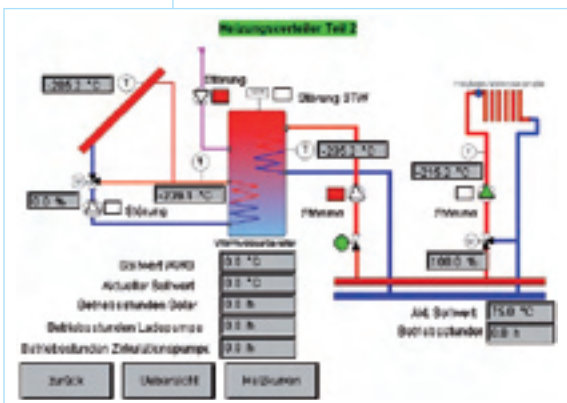

The S-Web editor - and with it our innovative web-based HMI concept – enjoy great popularity. Ever more customers recognize its advantages and benefit from using it in their projects. The number of users is growing rapidly and has already exceeded 240.

### Web page editing with ease and efficiency

A big advantage of the S-Web editor is its easy, intuitive operation. Just a brief introduction is sufficient for users to be able to construct their own web-based user interfaces.

With the basic objects provided, simple HMI pages can be edited quickly and efficiently.

Existing system images, logos, pictograms, etc. can be transferred directly in the form of GIF graphics, without having to redraw them.

Appealing, functionally designed web pages are the public face of any machine or system. They also support efficient, safe operation. It is therefore important to define a standard design and control concept, before starting on the actual work. Editing templates and using them is helpful. If the maxim “edit once and use often” is followed, valuable time will be saved when editing web pages.

This is perfectly supported by the web editor with background and foreground pages.

The «Background Teq» appears in the background of the current web page. It can be used to produce page templates with uniform design elements, such as company logos and/or uniform control concepts (e.g. navigation menus).

The «Foreground Teq» appears in the foreground and covers the current web page. It is ideally suited to the cyclic monitoring of states in the background, while overlaying/displaying appropriate events in the foreground. This is a very easy method for the event-controlled overlaying of error or other messages on the current view.

Compared with other HMI editors, the web editor can be used to edit and use any number of templates. This offers a high level of flexibility and simultaneously reduces the engineering cost. Within a single project, control concepts can very easily be implemented to match different operators or system parts.



Background template



This view uses the background page



The foreground page can be used to overlay messages

News Ticker

New documentation  
Saia® S-Web-Editor



Curious about the new version of our Saia® S-Web-Editor? Then simply download our newest documentation under:  
[http://www.sbc-support.ch/ti/26-453\\_E.pdf](http://www.sbc-support.ch/ti/26-453_E.pdf)

New in version 5.10

There are many useful additions. Key features of some are listed below. Alongside the trend function, powerful alarm management is the main highlight.

Alarm capture and management

Process signals are monitored and alarms captured independently of the web browser in the PCD controller. Activation takes place and parameters are set with the CSF (Call System Function) or SFC (System Function Call) commands for xx7. A Fupla FBox library is also available for PCD-Classic.

Alarms are stored permanently in the PCD controller in lists that include their status (pending or dropped), date and time stamp, and acknowledgement status. Multilingual alarm texts can be stored in CSV files.

Up to 10 alarm lists can be defined and maintained in each PCD controller. How much memory is reserved for the alarms database depends on the type of PCD used and does not exceed 64 kBytes. Up to 4200 entries can be stored in the alarms database.

Several macros are available for displaying and processing alarm lists in the web browser. Alarms can be acknowledged and deleted. Filter and sort functions support the operator when processing these lists. The alarm history can also be stored as a CSV file on the browser PC and, for example, sent by e-mail for further analysis.



More interesting news

- Unicode allows multilingual HMI pages to be produced using Asiatic and Cyrillic character sets.
- "Hide/Disable" can now also be applied to group objects.
- "Password" macro with inactivity timeout and automatic logout.
- With the "ListControl" macro, users select an individual element from a predefined list.
- "TableControl" allows the tabular display and entry of values, text, states, etc.
- The "teqJumpEvent\_onPPO" macro forces an automatic page change by the PLC application.
- "MultiLine Painter" allows multiline text to be entered.
- Thanks to the "Zoom Function", this editor can be used for the precision editing of pages for low resolution web panels (e.g. the micro-browser panel with 1/4 VGA).
- Optimized download procedure for Java applets regarding memory resources and download times.
- For other details, see Technical Information 26/453.

Do you require a special function that goes beyond the standard ones?

No problem. We will write a custom macro for you, specially tailored to your needs.

What happens next?

The next official release of the S-Web editor is planned for mid 2007. The main emphasis of this version will be on even better integration within the PG5 Controls Suite, and on extension of the macro concept. ■

# Proven PLC technology combines with new memory and data structures for integration into the IT world

The requirements for memory structures in the controller setting differ from those in the IT world in many respects. This often makes data structures so incompatible that appropriate data exchange is impossible without specific software drivers. PCD3 devices, with their new flash memory modules and integral FTP or web servers, close this gap.

## IT-compatible data structures and interfaces

The new flash memory modules (SD flash cards) can be used to increase data memory in PCD controllers by up to 4 GBytes. This allows savings on external memory systems (such as data loggers or even PC systems). The PLC operating system has integral FTP and web servers that allow data to be exchanged with a higher ranking system, without the addition of specific software drivers. In this way, machines or installations equipped with the PCD3 can be integrated into existing IT systems (e.g. ERP systems) at any time and at no added expense. SD flash cards can also be removed from the PCD3 during operation, in order to copy their data with a commercial SD card reader to a PC system.

## Almost unlimited memory capacity for a variety of applications

The large memory capacity of the PCD3 controller also allows it long periods of independence from any higher ranking PC system. Any chosen process points (temperature, pressure, power consumption, system messages, etc.) can be recorded in its flash memory modules.

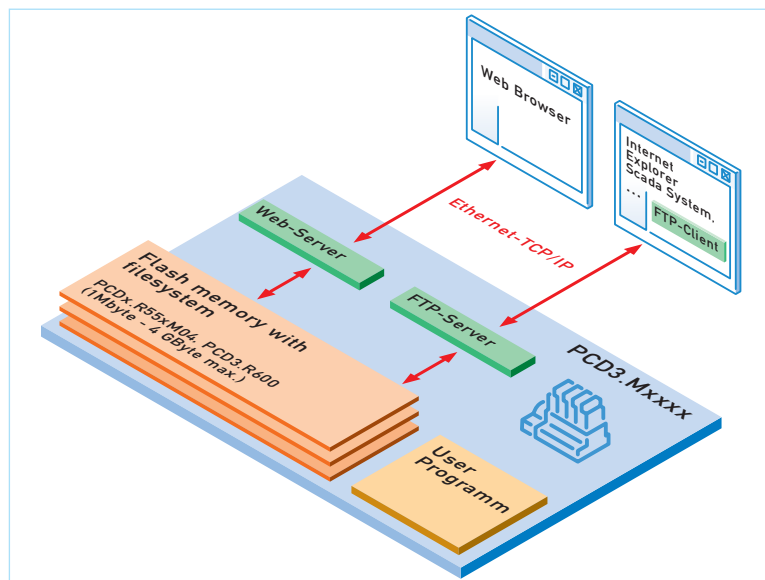

To do this, powerful IL commands and convenient Fupla FBoxes are available to users.

Memory can also be used by the web server to access web pages, GIF graphics, help files, etc. Basically, the file system in flash memory can be used to store any files or information required. An entire PG5 project can even be saved to it. This means that the most recent project status is stored directly on the machine/installation. The PCD's many different communications drivers for foreign systems (Modbus, Profibus, EIB, etc.) make it an ideal data concentrator and gateway for higher ranking systems.

copied by an FTP client to an office PC for long-term archiving. ■

## Advantages with PCD3

Thanks to the flash memory modules, no additional data logging systems are required for long-term data registration. A standard tool (FTP client) is used for exchanging data with the higher ranking system. The costs of additional tools or drivers are avoided.

## Practical example: long-term data registration in a cold-storage facility for quality control

A major store chain in Germany uses PCD3 systems to control a large cold-storage facility. The warehouse has a cooling area of approx. 15,000 m<sup>2</sup> and an overall cooling output of approx. 1.9 MW. The goods represent a value of several million Euros. For quality control purposes, room temperatures are recorded on a Saia® flash card over an extended time period. Recorded data is regularly

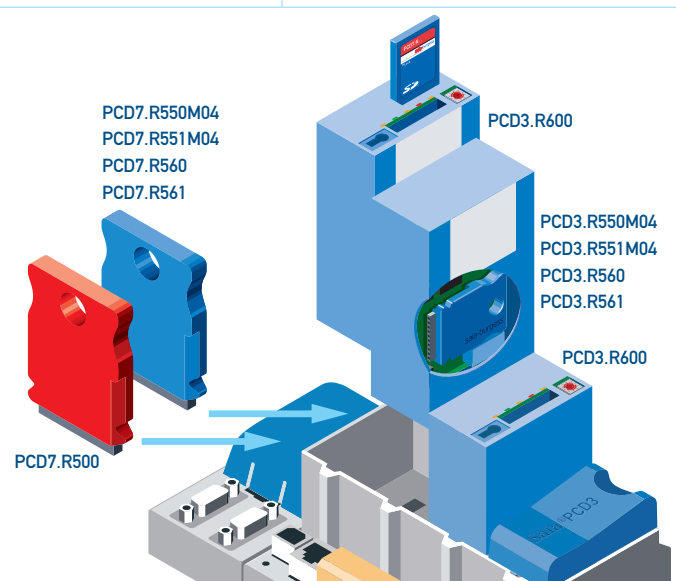
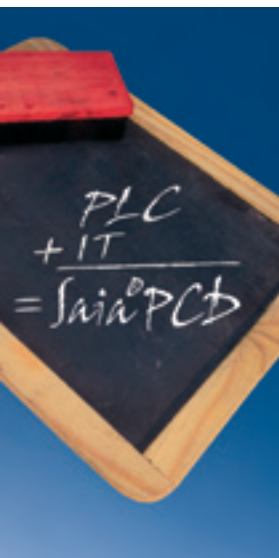

The new flash memory modules at a glance.



## Product Preview 2007

### Saia®PCD3.Compact General Purpose

#### Compact Power...

Compactness does not have to mean less capacity or less power – quite the opposite, at least in the case of the PCD3.Compact.

Based on proven, powerful PCD3 technology, the PCD3.Compact was developed as a general purpose controller.

20 digital inputs of which six are also configurable as counter inputs, 12 digital outputs, 4 analogue inputs and 2 analogue outputs (current/voltage) cover the demands of many applications. The 4 analogue inputs are configurable as current and voltage inputs (also -10...+10 VDC). The on-board memory, equipped with the new Saia®File system, is amply proportioned and large enough to include visualization projects stored on the PCD.

As communications ports, there are Ethernet with http direct support, USB and RS485 available on-board. In addition, there is a slot for an optional PCD7.

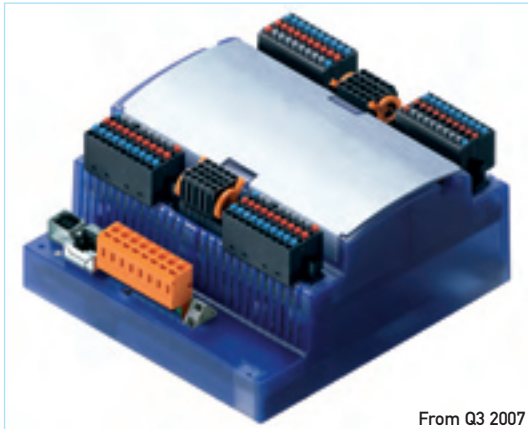

From Q3 2007

F1xx interface extension module. A choice of 5 F1 modules is provided, with various interfaces.

The elegant, removable housing cover allows access to the lithium battery (included in standard equipment) and the optional, plug-in F1 communications module.

Through the optional I/O connector system with LEDs, I/O status can be signalled locally to the PCD3.Compact. ■

### Saia®PCD2 New

#### Not just a futuristic design

Design studies are complete and today we can already show you what the Saia®PCD2 New will look like in future.

A semi-transparent cover over the central section forms the front of the Saia®PCD2 New. Two plug-in side sections allow speedy assembly or disassembly of I/O modules and module wiring – without any laborious removal of the housing cover.

The central section is screwed tight, to protect microelectronics. For communications modules, prestamped,

snap-out openings have been provided. Two slots are available for flash cards. Thanks to the guide rail in the central section, it has been possible to position the flash modules lying down.

Regarding technology, the Saia®PCD2 New is again very attractive. Expandable up to four serial ports and equipped with two RJ45 Ethernet connections, including switch, the Saia®PCD2 New is a communications prodigy. FTP access is supported, just like web access via http-direct.

6 digital inputs and 2 outputs are also available on-board. The possibility of configuring inputs in quadrature and running outputs as pulse width modulation (PWM) outputs even enables the Saia®PCD2 New to be used as an economic solution for machine and system construction. ■



From Q2 2007

## News

### PCD3.F2xx

New interface modules  
PCD3.F2xx for PCD3

These new modules allow the PCD3 to be extended with up to 8 serial interfaces. The modules are available either equipped with a fixed interface, or with a slot to receive an additional PCD7.F1xx interface module.

- PCD3.F210: RS422/485 fixed equipment
- PCD3.F221: RS232 fixed equipment

Protocols supported:

- Mode C (Modem, Belimo MP-Bus, EIB, Modbus, ...)
- S-Bus Data Mode

Modules are available for supply to pilot customers and will be supported in the PG5 from version 1.4.120. ■

### Memory Enlargement

PCD3 user memory doubled

With hardware version D, on-board memory (RAM & flash) was doubled as follows:

- PCD3.M3x20 unchanged at 128kBytes
- PCD3.M3x30 now with 512kBytes
- PCD3.M5x40 now with 1MBytes

From firmware versions ≥ \$28 and PG5 SP1.4.120, the larger memory will be supported. From early 2007, CPUs will be supplied ex factory with the new firmware. ■

### Industrial GSM, ISDN and analogue modems

Modems for mounting on DIN rail



The following types can be delivered from stock:

- Q.M716-KS1, 33.6kbps analogue modem
- Q.M726-RS1, ISDN modem
- Q.M736-AS2, GSM modem

DIN rail devices are compatible with PCD2.T8xx modems and can be used with the PG5 modem FBox library. ■

## News Ticker

### New: S-Web-Connect

The new Saia®S-Web-Connect combines S-Connect and Web-Connect in one product with a standardized user interface, enhanced performance and modern .Net look.

S-Web-Connect is now identical on Windows® CE and Windows® eXP and can be extended via plug-ins with the latest .Net 2.0 API. S-Web-Connect is ideal for easy-to-produce communications between applications and Saia®PCDs.

### PCD service made easier

To simplify service activities, Saia-Burgess Controls offers a modular, multi-lingual service application. Its integral script language and the possibility of incorporating existing web editor masks let you adapt this service application individually to projects. Updating of firmware, web editor masks and PLC programs is also possible without PG5/STEP®7.

### PG5 1.4 ServicePack 2

PG5 1.4.120 released. The new, official version PG5 1.4.120 (inc. SP2) has been published and made available for downloading under [www.sbc-support.ch](http://www.sbc-support.ch) (Product information/PG5). The new version supports the memory extensions of Saia®PCDs, the new PCD3.F210/221 communications modules and up to eight serial interfaces. OEM symbol files from Visi+ and Excel can be linked directly into the PG5 project, which simplifies automatic symbol exchange.

## Windows® and PLC Technology, the winning alliance

At a stroke, PC/Windows® platforms connect with the controller level: The PCD range of PLCs, with their modern CPUs, can work hand-in-hand with Windows®. These controllers have Windows®-compatible PLC technology, which means they include the standard Windows® interfaces. They not only have Ethernet and USB, but also web-based communications built on .NET or Java standards, and can therefore do without add-on hardware. Such interfaces no longer need the ballast of special field-bus cards, driver software, OPC servers, etc.



All too often, the question of whether to use PLC or PC technology in automation reveals a sectarian divide. However, if one considers the matter coolly and objectively, a combination of both approaches makes sense, because it opens up a wide range of new functionality and possibilities, without compromising the robustness of the control solution. In view of this, Saia-Burgess Controls offers Windows®-based HMIs, controllers and interface solutions that coordinate with each other perfectly to provide a bridge onto the Windows® world. By opening up its PCD range of controllers to Windows®, Saia-Burgess Controls has strengthened its claim to be a partner both for the committed PLC user and the enthusiastic PC programmer.

Saia-Burgess Controls has carefully designed the PCD range for Windows®-compatible connection. This is shown not only by the presence of standard PC interfaces (Ethernet and USB), but also by the PCD controllers' communications mechanisms, which can be used from Windows® directly, seamlessly and without additional software. They make it particularly easy to connect the controller level to PC applications – without licensed software drivers, OPC servers, or whatever.

### Windows®-compatible connection of field level

An essential argument in favour of using a soft PLC is the simplicity and speed with which data is exchanged between the controller and the PC ap-

plication. Since everything runs in the same memory, access mechanisms are efficient and trouble-free. In fact, connecting a traditional PLC to a PC is not always easy: there are additional field-bus cards to be sorted out, special software drivers or OPC servers to arrange, all of which ultimately still require licences. This is because most PLC manufacturers only direct their controllers' interfaces at the field level, and ignore established PC/Windows® interfaces, or only provide them in the form of costly add-on modules. However, Saia-Burgess Controls has taken its PCD range one step further, offering Windows®-compatible interfaces at all levels. This makes it easy for Visual-Basic/C# or Java programmers to access PLC data from PC applications.

### Communication via Ethernet, USB and serial ports

First consideration should be given to hardware level interfaces. All recent PCD controllers are now equipped with standard PC interfaces: Ethernet and USB. This provides guaranteed connection with modern interfaces, even at the lowest level. To complete the picture, all PCD CPUs also have traditional RS232/485 interfaces. No added software is needed for web-based communications (like a standard browser) on PCD controllers via an Ethernet port. Anyone who wants to use web technology to access the USB interface or a serial port can achieve this by installing a Web-Connect communications server on the PC. Web-Connect diverts any web access by the Windows® operating system (Browser, .NET/Java applications, etc.) to the USB and serial ports. Its function is transparent for both users and programmers.

### Web-based data exchange with web server and .NET classes

PCD controllers provide access to actual PLC data through an integral web server. This web server includes a CGI interface, allowing PLC data to be read or written with a simple URL (address information). This can be done 'manually' with a browser, or via standard programming languages. In fact, functions within the Java and .NET software platforms make light work of handling web contents (web contents

here are the PLC data of a PCD with web server). For example, with the WebRequest class, the new .NET platform allows files to be downloaded just by specifying the URL. In this way, data blocks, registers, flags, and even inputs or outputs can be read or written via the PCD's CGI interface. The advantage here is that no additional software components (e.g. special drivers, etc.) have to be present. Windows® already provides everything necessary for communication with PCD controllers.

### Web-based data exchange with files and .NET classes

Alongside the fundamental PLC data, PCD controllers offer a file system that can be accessed both internally and externally. Files can be edited, deleted, read or written from the PLC program. The file system is also externally accessible – e.g. from a PC. Using the same communications mechanisms as the CGI interface, files can, for example, be downloaded with the .NET WebRequest class. In addition, the file system can be accessed via the FTP protocol, which also makes file operations possible with standard FTP clients.

### Access with S-Connect and native PLC protocol

Those who prefer not to use a web server and CGI interface to access the PLC will like the S-Connect package. S-Connect offers communication based on S-Bus, built on .NET, and capable of using the .NET languages: Visual-Basic, C# or even C++. Essentially, S-Connect consists of a DLL that can be easily integrated into Visual-Studio projects. S-Connect therefore allows PLC data to be read or written with only a few, simple lines of program. Once integrated into a .NET application, S-Connect enables direct communication with PCD controllers, bypassing Web-Connect. As a result, there is no need to install Web-Connect on the target PC.

### Further information:

- Web Server manual classic: [www.sbc-support.ch/manuals/26-790\\_E.pdf](http://www.sbc-support.ch/manuals/26-790_E.pdf)  
xx7: [www.sbc-support.ch/manuals/26-775\\_E.pdf](http://www.sbc-support.ch/manuals/26-775_E.pdf)
- Windows System Information: [www.sbc-support.ch/ti/26-456\\_E.pdf](http://www.sbc-support.ch/ti/26-456_E.pdf)
- eWin Web Panel flyer: [www.sbc-support.ch/ti/26-424\\_E.pdf](http://www.sbc-support.ch/ti/26-424_E.pdf)

### Windows® platform and controller level from one source

Windows® offers immense functional diversity, which already implies a certain complexity. Things are not made simpler by the high level of modularity in embedded Windows® operating systems, such as Windows® CE or Windows® XP embedded. Embedded Windows® systems are individually tailor-made by the manufacturer to the platform concerned. Ultimately, the producer decides which functions the adapted Windows® will offer, and which it will not. When Java and .NET platforms also come on the scene, double-checks are needed to see whether the product in question actually provides the required (Windows®) functionality. To get round this kind of problem and build from the

outset on a runnable solution, Saia-Burgess Controls offers the appropriate Windows® platform alongside proven PCD controllers. Whether they use CE or embedded XP - Windows®-based control panels from Saia-Burgess Controls are best prepared for perfect interplay between control panel and PLC, and offer the openness of a standard Windows® platform. ■

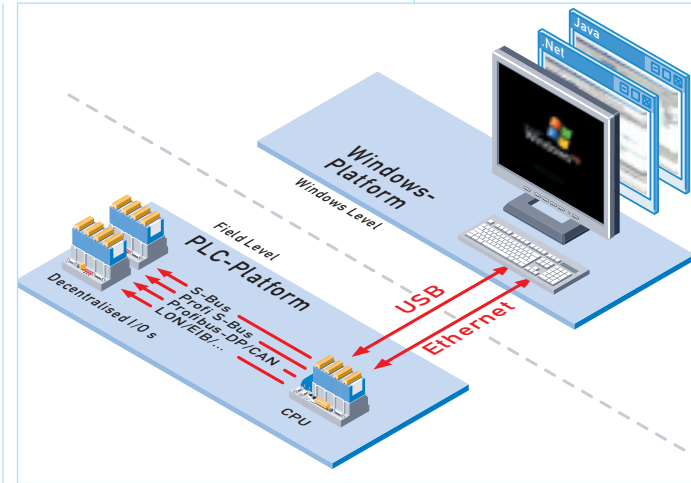

### How to: Set PLC outputs with a standard browser

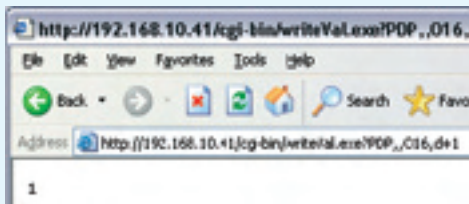

Set output 16 with standard browser

Even a simple, standard browser can be used to poll and set PLC data from PCD controllers. To do this, just enter the address of the controller, followed by a CGI command, in the browser's address field. With PCD controllers, CGI instructions are always initiated in the /cgi-bin/ directory. The required action will then take place.



### How to: Implement PLC communications with S-Connect

S-Connect from Saia-Burgess Controls is integrated into .NET applications and allows trouble-free access to PLC data, using the PCD's own S-Bus protocol.

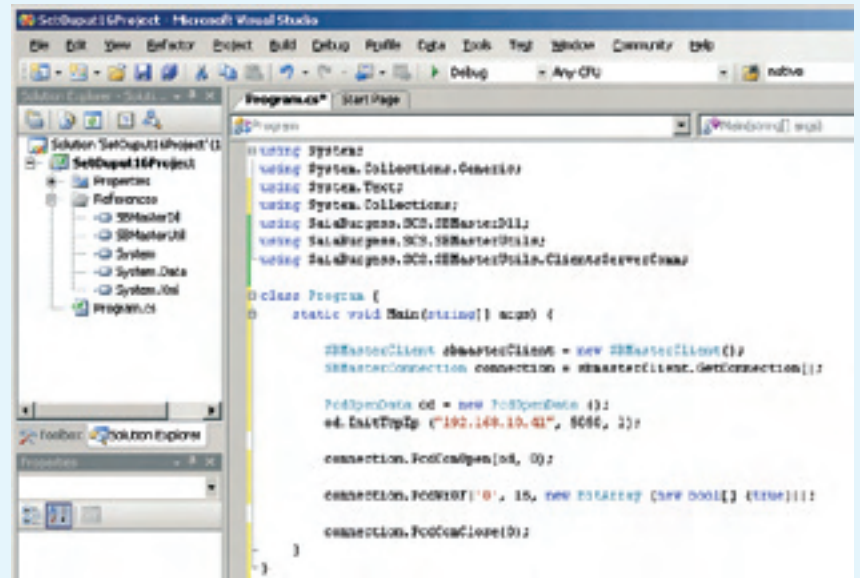

Set output 16 with S-Connect and C#

### How to: Access PLC data with .NET standard classes

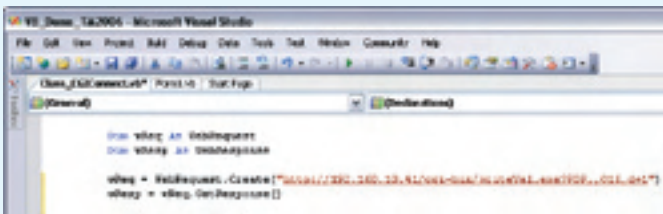

Set output 16 with Visual-Basic

.NET provides the WebRequest class, which can be used to access PLC data in exactly the same way as with a standard browser – except using Visual-Basic or C#.

### How to: Exchange data via files and .NET standard classes

With the .NET WebRequest class, complete files can also be loaded from a PCD controller.

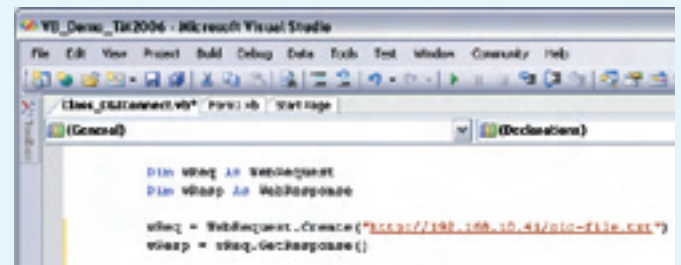

Load file from PCD with Visual-Basic

# Energy meters – on the mains and networkable

Product announcement Saia®S-Bus interface for networking energy meters

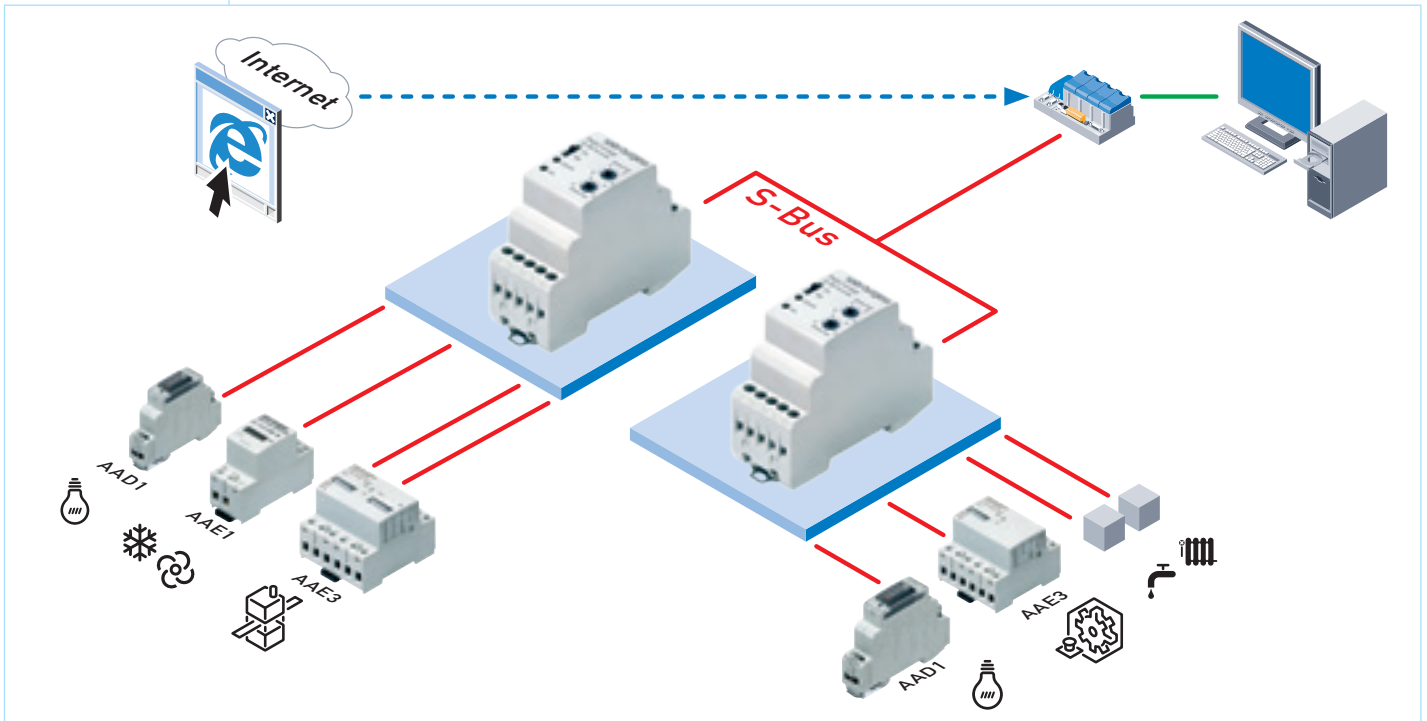

Whether in shopping malls, residential complexes, camping sites or marinas, rising energy costs have led to an increasing demand for consumption-based charging, in preference to the all-inclusive invoicing of energy costs.

This desire is understandable, but if it were applied to a shopping mall with 100 or more businesses, it is quite certain that the expense of installing and reading conventional energy meters would be greater than any benefit.

This is why Saia-Burgess Controls Ltd offers a range of small, economical energy meters. Alongside their built-in counting mechanism, they also have a count pulse output for central energy registration in a Saia®PCD, with automatic processing of individual invoices by PC. In addition, ongoing consumption is indicated via LED.

These energy meters are shock and vibration resistant, and cannot be tampered with, either manually or by using strong magnets. As a result, correct accounting of electricity costs is guaranteed at all times.

In spring 2007, Saia-Burgess Controls will add an S-Bus interface to the range. Networking will then be achieved via the Saia®S-Bus, rather than wiring individual count pulse outputs in parallel.

The wiring costs of larger projects, for example in building automation, can therefore be significantly reduced.

Up to 100 interface modules can each have 4 energy meters connected. This allows up to 400 electrical consumption values to be transferred simultaneously across the Saia®S-Bus to a higher ranking Saia®PCD controller. Here, an FBox software module supports the further processing of data for the individual invoicing of consumers.

An ideal solution at a competitive price. ■

## Energy meters from Saia-Burgess Controls: a success story



Only recently, Saia-Burgess Controls began launching a new range of energy meters on the market. All staff members involved in the project clearly saw that, with rising energy costs, increasing importance was attached to capturing and controlling power consumption data. Today's product range comprises compact, 1-phase and 3-phase energy meters. Our customers have given these products, in both the calibrated and uncalibrated versions, an enthusiastic reception. Part of this success is also due to their being "Made in Switzerland", a quality seal that guarantees the robustness and reliability of these energy meters.

These attributes have been rewarded by our customers.

In the first half of 2006, sales rose by 50 percent.

# INFRASTRUCTURE AUTOMATION

## Application light / shade

### Integral solution for electrical plant

With its light and shade modules, Saia-Burgess Controls intends to do full justice to the term “inter-plant”. These modules, which have been specially adapted for the light and shade field, bring HEAVAC and electrical plant closer together.

By combining digital inputs and powerful outputs on a single module, even time-critical processes (such as louver adjustment) can easily be solved with an autonomous mode of operation.

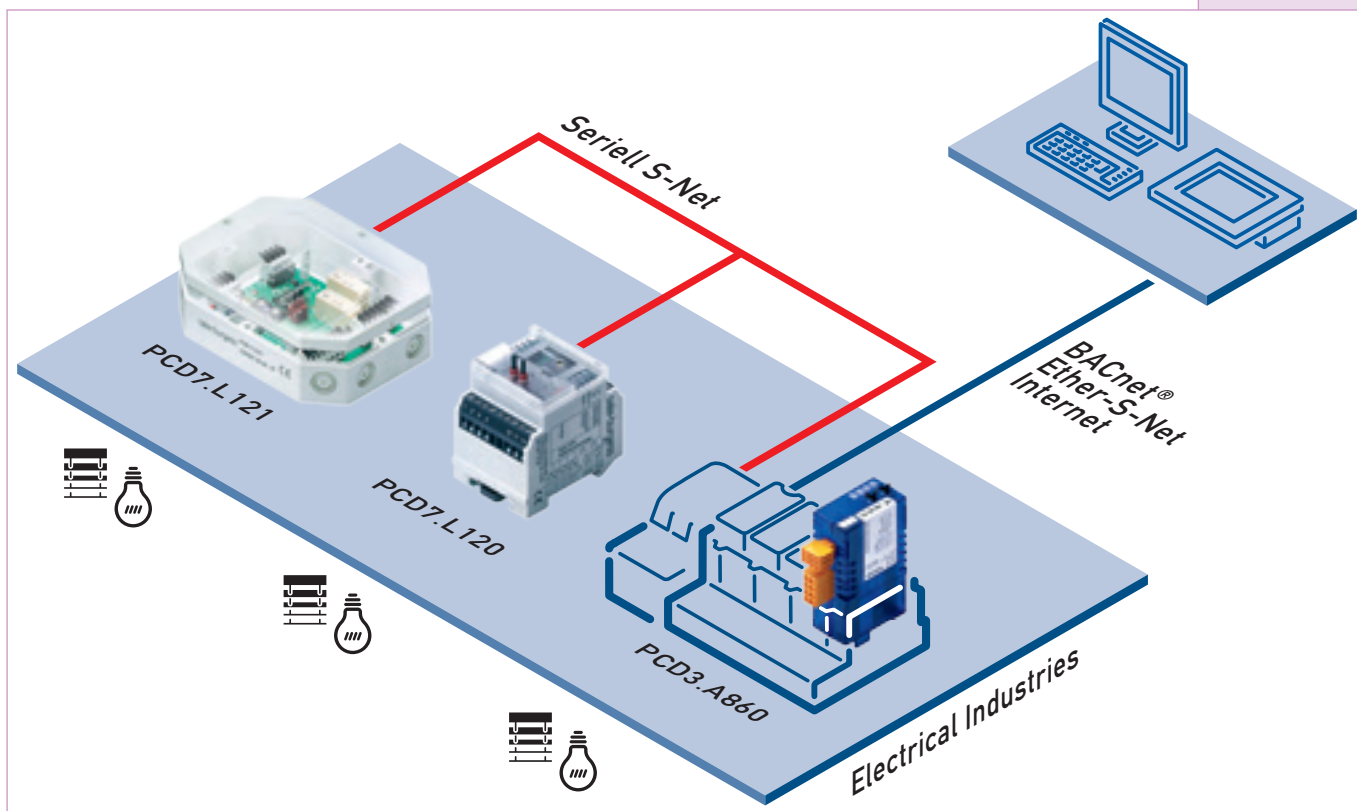

#### Module features

- Selectable applications: light/shade or RIO mode
- Application solution for autonomous operation, or as Serial S-Net slave module
- Network connection to RIO module or PCD3 base station with Ethernet. Ether-S-Net, BACnet®, etc.
- Web connection and control via master station
- Intelligent modules with direct action on input information
- Integral power relay with manual control
- Prefabricated cable for ease of installation

#### Light, shade and RIO mode functions

Room automation comprises not only temperature, humidity and air quality regulation, but also the control of light and insulation. Temperature-controlled ventilation, shade and light control all have an important influence on the wellbeing of the users of a room. Saia-Burgess offers a standard, total solution for room automation, from temperature regulation to the control of light and shade functions. Multifunctional applications modules allow three different modes to be used: light, shade or RIO mode. This offers users the greatest possible flexibility in practice.

All applications modules have a network connection that allows central, remote access by groups or overall systems. This allows central control for higher ranking room requirements, depending on the weather situation, light conditions, or time-dependent effects.

The positive contribution this makes to the energy efficiency of a building is considerable. ■

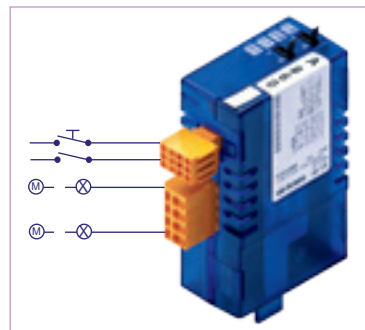

The PCD3.A860 new light and shade module is now available

Product Information

Flash memory modules with BACnet® option, file system, program and data backup

Pluggable flash memory modules PCD7.R5xx on slot M1 or M2 of PCD3.M5x CPUs

- PCD7.R560  
Flash module with BACnet® option
- PCD7.R561  
Flash module with BACnet® option, 1MByte file system and 1MByte program backup



With type designation PCD3.R5xx such modules can also be fitted into CPU I/O slots #0...#3. These modules allow memory extension with PCD3.M3x CPUs.

- PCD3.R560  
Flash module with BACnet® option
- PCD3.R561  
Flash module with BACnet® option, 1MByte file system and 1MByte program backup



## Saia®PCD3 controller gets BTL logo

After the successful conclusion of testing at WSPLab in Stuttgart (the certified BACnet® test laboratory) and approval from BIG-EU (BACnet® Interest Group Europe), the following PCD3 controllers now bear the BTL Logo:

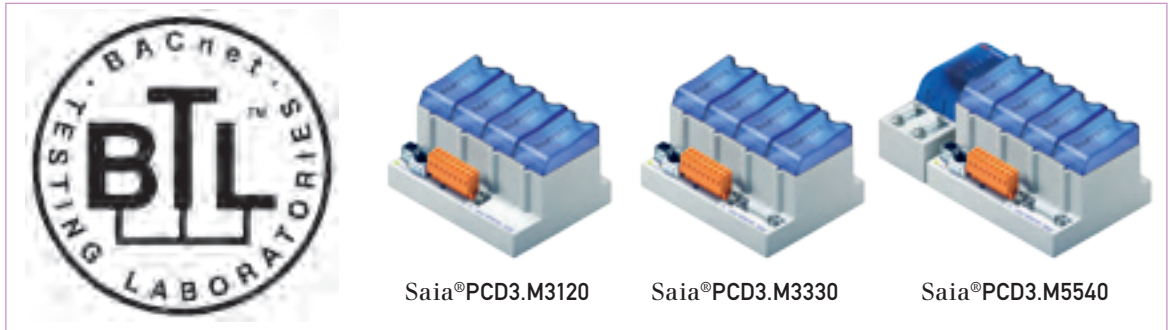

The logo can be found directly on flash modules PCD7.R560 and PCD7.R561, and on modules PCD5.R560 and PCD3.R561. A detailed description of functionality can be consulted in the

document: «Protocol Implementation Conformance Statement» (PICS) Doc #26-848. ■

## Easier integration, thanks to BACnet® in Den Helder

In the company headquarters of "Woningstichting Den Helder", BACnet® has provided the perfect connection for devices from Daikin, Remeha and Saia Burgess Controls, achieving a pleasant climate and maximum energy efficiency.

The building, which dates from 1925, was totally renovated in 2005 and provided with a structural extension. The old part of the building retained the existing heating system from Remeha Quinto. The new part of the building was provided with a VRVII system from Daikin. This system also covers the ventilation section in the old building. All ventilation equipment

can be read and operated via Daikin's D-BACS gateway for BACnet®. The Saia®PCD3's powerful BACnet® client function therefore allows the seamless integration of ventilation within an energy-optimized heating and ventilation concept, implemented with a Saia®PCD3 substation and Saia®Visi+ management station. ■



Outside view of the renovated company headquarters of "Woningstichting Den Helder"



Switch cabinet with Saia®PCD3 BACnet® station (top left) and Daikin's D-BACS gateway (bottom right)

# Flexible BACnet® topologies with Saia®PCD3

The Saia®PCD3 is extremely flexible and can be used in a wide variety of network topologies. The following three examples demonstrate this characteristic.

### Example 1

This example concerns a distributed IP network, in which different Saia®PCD3s communicate with each other and with a BACnet® management station via BACnet®/IP. Since the network is divided into several IP subnetworks, the Saia®PCD3's BBMD functionality (BACnet® Broadcast Management Device) is utilized here. All the PCD3's available communications modes can still be accessed, therefore allowing the simultaneous connection via RS 485 of a serial S-Bus subnetwork with various Saia®PCD/PCS stations.

The PCD3's client functionality allows freely programmable exchange of data with other BACnet® servers. These may themselves be PCD3s, but can also be products with a BACnet® interface from other suppliers within multi-vendor systems.

Since BACnet® stations find themselves automatically at the start of communication via broadcast telegrams, the programming of stations in a complex BACnet®/IP network is almost the same as for a single subnetwork.

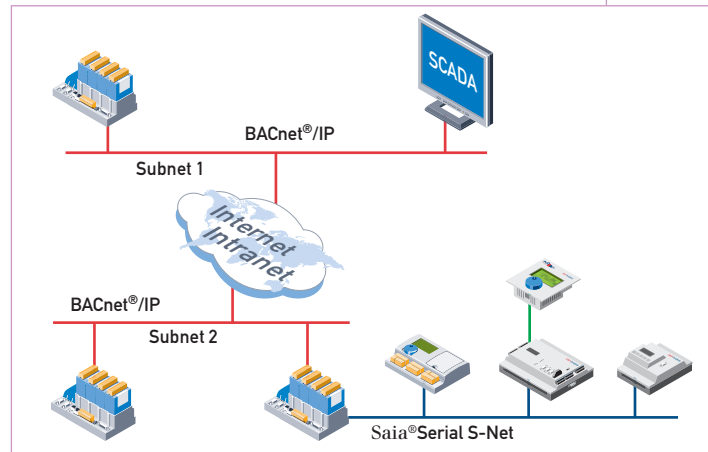

### Example 2

The possibilities with modem communications are shown here.

A remote IP network comprises two PCD3s, connected via Ethernet cable. Alarms can be sent via a common modem, and a management station polls history data periodically.

To send a BACnet® alarm message (green arrow) the station 0 can itself dial up the modem connection to the management station. Station 1 can remotely operate station 0's modem driver and so transmit its own alarms to the management station.

If for any reason no connection is possible with the management station, an SMS (red arrow) is sent from station 0 to a predefined alarm destination.

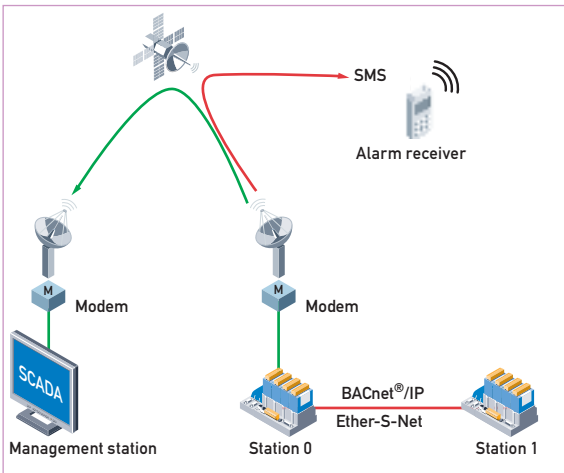

### Example 3

This example shows how data on a Saia®PCD3 can be simultaneously and synchronously displayed and controlled.

Any choice of BACnet® client can be used to represent data via BACnet®/IP, in just the same way as the entire family of Saia®PCD web panels with HTTP direct. However, added to this is support for serial connections, such as the RS232 connection of a Saia®PCD7.D230, or Saia®Serial-S-Bus for a Saia®PCD Web-Panel MB (with micro browser). This offers the possibility of scalable control to match whichever project is concerned, even with BACnet®! ■

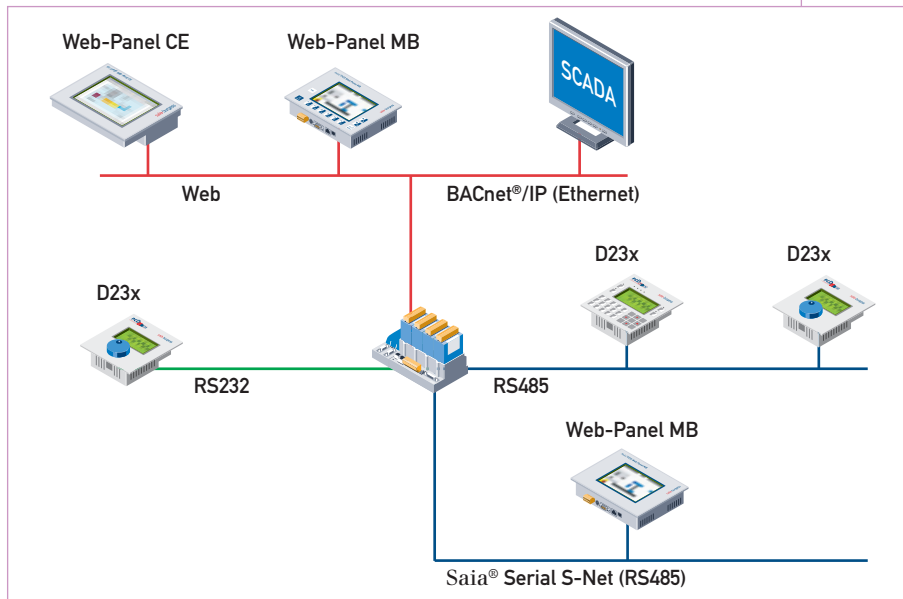

News Ticker

New cables with 90° bent connectors for PCD2.K106, PCD3.K106 and PCD3.K116



PCD3 manual control module with cable and bent connector

The redesign of the connector allows unlimited use of PCD3 manual control modules on all slots. System integrators can use them to optimize PCD3 configurations and costs. From January 2007 this new version will replace completely the previous one.

# ViSi+ Version 1.4

The Saia®Visi.Plus building management system has been further improved and new functions have been added.

Summary of main new functions:

- Additional graphical objects: such as options fields, radio buttons and drop-down lists
- Additions to Alarm Manager and Remote Alarms
- Extended print function
- Auto-answer mode (event-controlled alarms from automation to management levels)
- S-Driver transfers text and data blocks
- Free adjustment of monitor resolution (important for web applications)

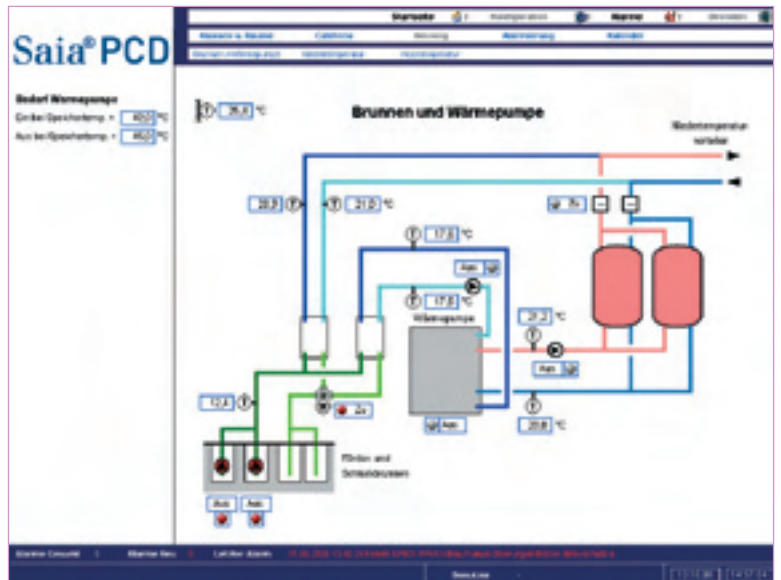

Visi.Plus Version 1.4 is equipped with a runtime USB dongle. This will be needed just for the runtime version. As before, project design will

still be possible without dongle protection.

From October 2006, a beta 1.4 test version is available on [www.visiplus.org](http://www.visiplus.org).

The deadline for the official version is January 2007. ■

# Saia®DDC.Plus system catalogue

“The standard work on building automation” is how the technical press described the 154-page Saia®DDC.Plus system catalogue.



The new edition of the catalogue clearly and rigorously sets out product, system and concept solutions for building automation. System integrators and planners in particular will appreciate the practical, straightforward way it presents possibilities offered by the wide range of Saia-Burgess Controls products, displaying them in text, pictures and diagrams.

Inter-plant system solutions, communications capabilities via web-based control and automation systems, even management systems: all are described in concrete terms. Remote input/output modules, room control systems, and control box coupler modules are indispensable additions to the portfolio. A large chapter is also dedicated to flexible programming systems. These make configuration and programming

much easier, not least because of their comprehensive libraries and graphical capabilities.

This standard work on building automation is currently available in German and English. From December 2006 it will also be available in French. ■



# MACHINE CONTROL

## Yes, You CAN!

Anyone who has already implemented CAN in production machines or equipment, will still want to be able to use it in any new generation of machines or equipment. Anyone who has done without CAN up until now, will not want to start afresh with it today. Anyone who has used CAN to produce complete automation systems in project business will, in the meantime, be plainly on the wrong technical track.

This summarizes, in a few sentences, our viewpoint regarding CAN. The way in which we have implemented CAN in our organization and product range derives from this viewpoint.

We direct ourselves explicitly towards customers who already use CAN today in a production device, and not towards entry-level CAN users.

### What do existing CAN users need?

#### 1. Compatibility with their own past

CAN users want to be able to map all the specific features that "their" CAN system has developed over the years onto a new generation. This must also be possible without special firmware, and without dependence on the hardware supplier. Unlike Profibus or Interbus, CAN was always the bus of creative and cost-sensitive applications.

To meet this requirement from the bottom up, we have produced a truly open CAN implementation in the Saia®PCD.

Three different CAN operating modes can be used simultaneously:

#### 1. CAN Data Mapping

For applications where only cyclic process data has to be exchanged between two CAN devices.

#### 2. CAN Basic Services (BasicCAN)

Allows simple handling of CAN communication in the user program with the help of send and receive queues.

#### 3. CAN Direct Access (FullCAN)

Offers the full functionality of the CAN controller, thanks to direct hardware accessing of all 32 Buffers.

With these three operating modes, CAN open functions can also be generated directly from the user program, alongside many proprietary protocols.

In the Saia®PCD Classic software setting, CAN configuration takes place with the help of the Saia®CAN configurator, which can be integrated as an add-on tool into Saia®PG5 programming software. CSFs (classic system functions) can be used both for configuration and for the CAN function. For Basic Services Mode additional Saia®FUPLA FBoxes are available for the CAN function.

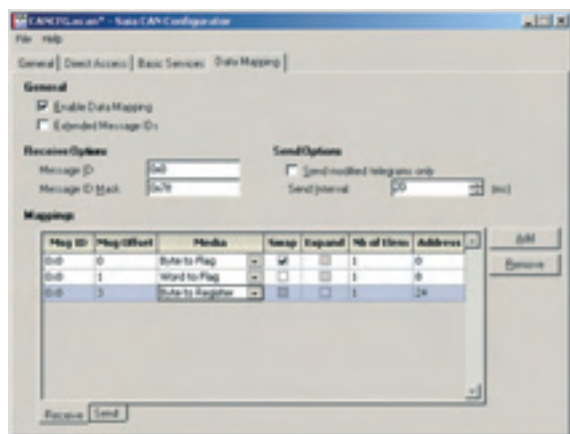

CAN configuration with Saia®PG 5 Controls Suite

Anyone who uses Siemens® STEP®7 as a software environment already works with SFBs (system functions) for the configuration and programming of CAN operating modes.

Address	Block Call	Loc. Name	Type	Access	Comment
4.0.0	Net ID	NET	0		Net ID/ID-Filter
2.0.0	Transmit	TRM	0		Transmit request in Profibus and CAN
4.0.0	Receive	RCV	16B		Receive
4.0.0	Profibus	PRO	0		Profibus interface (ID: Master: 40-47)
4.0.0	Profibus	PRO	0		Profibus interface (ID: Master: 40-47)
4.0.0	Profibus	PRO	0		Profibus interface (ID: Master: 40-47)
4.0.0	Profibus	PRO	0		Profibus interface (ID: Master: 40-47)
4.0.0	Profibus	PRO	0		Profibus interface (ID: Master: 40-47)

#### 2. Motivation for change of supplier or system

Since we had no CAN products in our programme until recently, a decision for Saia®PCD CAN will always be a decision against an existing supplier, or against an established system concept. The PCD5 range, stuffed with IT technology and communications capabilities, is our trump card here. The fact that we also combine CAN with Siemens® STEP®7 on a single PLC CPU is, for many, another powerful argument.

### From past experience, the motivation to change is particularly strong in the following cases.

- CAN-PC cards have been used previously. The intention for the future is that regulation and time-critical control functions should run independently of a PC. Nor should there be any further need for additional hardware or special firmware drivers in the PC/Windows device.
- Proprietary controllers are used, but replacement is imminent due to their age. Since the last in-house system development, demands on controllers have increased enormously. It is then often clear that a completely new development would be too risky, costly and laborious.

With CAN, USB, Ethernet, RS232, RS485 and Profibus on-board, the Saia® PCD3.M634x is a communications genius. The standard transmission format with 11 bits (CAN2.0A) and extended transmission format with 29 bits (CAN2.0B) are supported. For the CAN bus, a transmission rate of up to 1 MBit/s can be configured. For the application program, 1 MByte of RAM is provided, with 1 MByte as backup memory. ■



OEM-specific version of Saia®PCD 3.

All sensors and actuators used previously in the various machine types can be connected via CAN with compatible functions and connections.

PCD 3 M634x standard controller

# Build your own control environment – even at software level... with the Saia®F-Box Builder editor function

Ideal for OEM customers and system developers. Extend the hardware manufacturer's standard library of graphical application modules by adding your own perfectly tailored function blocks.

Although the ZIP function is included as standard in the Saia® PG5 Controls Suite, before you can develop your own graphical function blocks, the Saia®F-Box Builder editor function must be enabled.

This function is only enabled after thorough training, to ensure that your investment will bear fruit. Although the majority of our customers do not use the editor option for themselves, those customers who have extended the Saia® standard library with function block libraries constructed by themselves are, evidently, very successful with them. It pays to invest!

Two typical application examples from machine building are described below:

### Motion Library – Idea (I):

The «Mythos» stamp press is a VOLUMETRIC COLD-PRESS.

More than 10 motion axes are controlled by one PCD2 controller with synchronized PCD2.H32x motion interfaces.

Motion control is programmed with FBoxes in FUPLA – created by the client.



Thanks to Saia®FBox-Builder, the client's development know-how has been protected and the whole application made easier to commission and service.

### Polystyrene (EPS) machines:

A major German machine manufacturer encapsulated key know-how and critical processes within its own FBox library. Thanks to the easy graphical programming environment provided by Saia®PG5, the same service personnel who install the machines can now also carry out basic modifications and

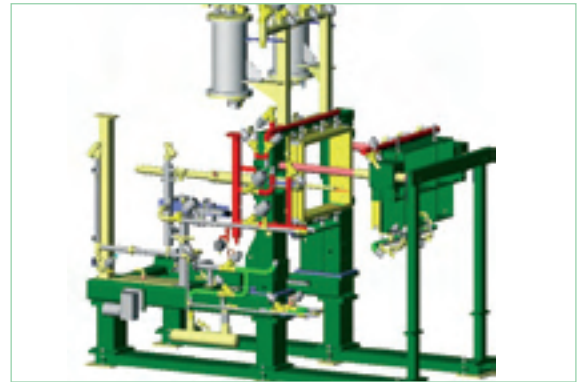

adaptations to machine logic. Service personnel also use the Saia®PG5 for commissioning and fine tuning the machine.

A PLC programmer is no longer required to travel from site to site to make changes to the machine logic.

The system is so efficient and attractive that the company has switched completely from Siemens Step®7 to Saia®PG5.

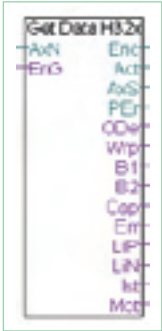

PCD2.H32x Library



FUPLA Page

Have we awakened your interest? Read more about Saia®FBox Builder in our System Information document ([http://www.sbc-support.ch/ti/26422\\_D.pdf](http://www.sbc-support.ch/ti/26422_D.pdf)) or look at the tutorials under [www.start-controls.com/fbox/](http://www.start-controls.com/fbox/). ■

### Why FBoxes and Saia®FBox-Builder?

- Programmers' work can be reused in many projects, rather than being edited from scratch each time
- Staff require no special training to realize projects. Fewer capacity bottlenecks. Minimization of risk from staff changes
- Company automation standards can be set and maintained. Programs can be used safely and easily across boundaries between departments, businesses and countries
- Even the hardest, most complex functions in the fields of communication, motion, networks and data processing can safely be used without previous knowledge
- Reduction of programming complexity by packaging into graphical blocks with high functionality
- Manipulation and know-how protection : Text version of original program cannot be read or modified by unauthorized people
- Unforeseen costs and commissioning delays are avoided. Once FBoxes have been developed, tested and documented, they are eliminated as a source of system errors
- Reduced maintenance and service expenditure : Even staff with basic qualifications quickly find their way around the graphical environment and can use the convenient, secure commissioning operations of Saia®FBoxes

# TECHNICAL SUPPORT

## FAQ Manager

In the FAQ Manager under [www.sbc-support.ch/faq](http://www.sbc-support.ch/faq) approximately 600 FAQs can currently be viewed. A few examples of useful FAQs are given below:

### PCD3 with MP-Bus interface PCD3.F180 – Error: No card echo

Problem: error message “No card echo” in the single master FBox of the MP-Bus library.

Possible causes:

- The PCD5.F180 module is not in slot 0
- Channel 1 has not been selected
- A gateway or S-Bus master port has been configured at channel 1
- Missing F180 module. Open cassette and check presence of module
- Use of an unofficial firmware version, e.g. \$26
- Faulty PCD5.F180 module

Source: FAQ 100611

### Are there .dxf files or other CAD drawings of PCD systems

For the PCD5 there are .dxf files and EPLAN macros (PCD5.Mxxx0 page on [www.sbc-support.ch](http://www.sbc-support.ch)). Why don't all products have these files? We faced widely differing requests. There are a great many CAD systems on the market and we therefore decided to build up experience with PCD5 and EPLAN, and check whether the demand justified the considerable expense. Files are available for downloading free-of-charge.

Source: FAQ 100444 ■



## News

### Incompatibility of PCD3.Mxxx0 with PG5 1.3 and PG5 1.4

For most PCD5 CPUs, a main memory extension is in preparation and will be available from hardware version D (already circulating) and firmware 050 (Q1 2007). Sadly, for PG5 1.3.100/110/120 and 1.4.100/110 there is incompatibility with PCD5 CPUs that have the above version or later ones. With the PG5 versions mentioned, it is not possible to load the hardware configuration into CPUs that support the extended memory. Both service packs PG5 1.4.120 and PG5 1.5.150 correct this incompatibility. We urgently recommend updating all your computers at the first opportunity. Otherwise, you may find yourselves confronted with this incompatibility in your installations. New versions are available on the PCD8.P5 page of [www.sbc-support.ch](http://www.sbc-support.ch). ■

### Corruption of RAM contents after power outages

PCD5.M5 CPUs have no batteries. A supercap is provided for saving RAM contents. The bridge time of this supercap is at least 8 hours. In recent months, when power outages have exceeded this guaranteed bridge time, there have been cases when partial losses of RAM contents were not detected on start-up and the CPUs went into RUN or HALT with modified data or program parts. This affects the PCD5.M5xx0 with firmware to version 024. CPU types PCD5.M4xx0, PCD5.M5xx0 and PCD5.M6xx0 are NOT affected. Correction: firmware update to a version >024. Firmware is available on the PCD5.Mxxx0 page of [www.sbc-support.ch](http://www.sbc-support.ch). ■

### Replacement of PCD7.F650 Ethernet modules with PCD7.F655

Ethernet modules for PCD1, PCD2, PCD4 and PCD6 are now called PCD7.F655. Hardware and use in applications are identical to the previous model, PCD7.F650. The firmware of the module has been rewritten, based on a new TCP/IP stack, in order to guarantee the serviceability of the module. Experiences with the new version have been very positive. In case of problems with PCD7.F650 applications, it is worthwhile updating the module firmware and thereby converting to a PCD7.F655. This firmware is available on the PCD7.F655 page of [www.sbc-support.ch](http://www.sbc-support.ch). An update guide will be found in the FAQ Manager [www.sbc-support.ch/faq](http://www.sbc-support.ch/faq). ■

### Corrupted values with synchronous mode in Fupla editor, PG5 1.4.100 and 1.4.110

With PG5 1.4.100 and 1.4.110, the corruption of values in analogue, counting and motion control modules may occur when the programmer is online in synchronous mode. Synchronous mode was only introduced with PG5 1.4.100 and is switched on as standard. We recommend that PG5 1.4 Fupla users update urgently to version 1.4.120, which is available for downloading on the PCD8.P5 page of [www.sbc-support.ch](http://www.sbc-support.ch). ■

### Phase out of analogue modules PCD2.W1xx

PCD2.W1xx four-channel analogue modules with 12 bit resolution have been superseded by more recent mod-

ules (PCD2.W5xx without electrical isolation, PCD2.W5x5 with electrical isolation). The new modules not only have 7 or 8 channels, but are also lower in price. Orders will be accepted up to 31.12.07, after which repairs will still be carried out for at least 5 years. ■

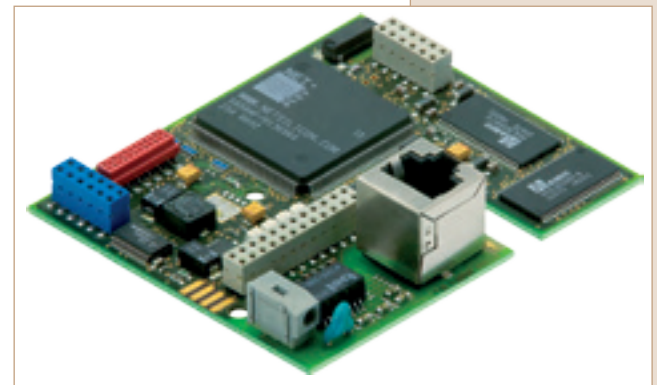

Ethernet module PCD7.F655

**RoHS conformity of Saia®PCD and Saia®CC**



Saia-Burgess Controls has introduced the RoHS directives (restriction of hazardous substances) for the production of PCD and PCS controllers and control components, such as timers, electricity meters and monitoring relays.

Actually, Saia-Burgess controllers do not come under EU Directive 2002/95/EG (RoHS),

since they are category 9 products (monitoring and control devices), which are excluded from this directive's current application list (Article 2, Paragraph 1). In addition, as far as we know, they are used as integral parts of fixed installations, which are also outside the scope of this directive, according to Appendix IA of EU directive 2002/96/EG (WEEE).

However, although we are not under any obligation, we have decided to comply with RoHS directives in the production of all our current product range, because we place great importance on protection of the world environment, and because our business is worldwide.

At the beginning of 2006, electronic product manufacturing in Murten switched completely to lead-free processes and bought-in components meet RoHS directives. Our manufacturing processes were converted and staff trained accordingly. For older products, typically spare parts or products nearing the end of their lifecycle, there are unfortunately still a few components that are not available in lead-free technology. We are therefore currently marking all product packs that meet RoHS directives with a crossed out Pb symbol.

We will apply this marking until all products in Murten stock meet the RoHS directives. As soon as this is achieved, we will drop the practice of marking with a crossed out Pb. From that time, the date printed on each product will be the valid reference.

We therefore strongly advise all our customers to manage their own stocks strictly in accordance with first in – first out principles, to ensure that older, non-RoHS compliant products are sold first. ■

**New cables with 90° bent connectors for PCD2.K106, PCD3.K106 and PCD3.K116**

The redesign of the connector allows unlimited use of PCD3 manual control modules on all slots. System integrators can use them to optimize PCD3 configurations and costs. From January 2007 this new version will replace completely the previous one. ■

**Extension of Technical Support in USA**



To increase our local competence for technical support, training, project support, program adaptations, etc., we have concluded an agreement

with Tell Tech Service Corp, a company managed by a Swiss citizen and long established in the USA.

His long experience in the field of machine and infrastructure automation

gives him the necessary applications know-how to deal efficiently with all types of demands.

Should you need personalized support in the USA, please feel free to contact Tell Tech Service (dan.bacher@telltechservice.com) or Saia-Burgess in Arlington Heights (IL) (kurt.luthi@saia-burgess.com). ■

**New address for Saia-Burgess Controls in USA**

Please note that Saia-Burgess Controls has moved from Vernon Hills to Arlington Heights. The new address for orders, customer service and technical support is:

**Saia-Burgess USA Inc.**  
3115 North Wilke Road, Suite C  
Arlington Heights, IL 60004  
Phone : +1 847 368 2146  
Fax: +1 847 368 2152  
E-mail: kurt.luthi@saia-burgess.com ■



**Presence in China strengthened**



Following the establishment of our official sales company in Shenzhen at the start of this year, we are proud to welcome Mr K.K. Wu as Saia®DDC Plus Sales Manager.

Mr Wu's wealth of experience in building automation opens up great business development potential both for existing and new Saia®PCD system integrators. You now have a competent partner to talk to in China, who can help you optimize your tendering in the DDC Plus field. ■

**UL approval for Saia®PCD3 range**

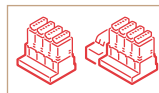

In June 2006, our PCD3 controllers were awarded official UL approval by Underwriters Laboratories Inc.

Saia®PCD3 devices meet the requirements of UL508 (industrial control equipment) and CSA C22.2 No 142 (process control equipment).

This is good news for all our customers in machine and apparatus engineering who export to the USA and/or manufacture there. ■

**Approval of Saia®PCD3 range for shipbuilding**

In July 2006, our PCD3 controllers were officially awarded shipbuilding approval by Det Norske Veritas.



Saia®PCD3 devices meet the requirements of Det Norske Veritas for ships classed as "High Speed & Light Craft" and the Det Norske Veritas' "Offshore Standard".

PCD3s have also received approvals from Polski Rejestr Statkoro and Germanischer Lloyd.

These approvals are an additional testimony to the seriousness with which Saia-Burgess Controls has developed and produced Saia®PCDs for over 25 years. They also show the continuity of Saia-Burgess' activities in shipbuilding, which began many years ago with the PCD4 and continues with the PCD2, PCD1 and PCD3 series. ■

**New manual control module for light and shade: PCD3.A860**

The light and shade manual control module is now fully released for sale.

This module has two digital inputs and 2 relay outputs in combination with manual control switches. It has been designed for the relatively high currents typically found in light and shade applications.

The PCD3.A860 module ideally complements the two other modules in this range: PCD3.A810 and PCD3.W800. For all 3 modules, preassembled connecting cable is available. ■

**PCD1.M120 and PCD1.M130 models give way to successors: PCD1.M125 and PCD1.M135**



The transition from one generation to the next has been a smooth one.

Customers appreciate the full compatibility, associated with important improvements, such as a larger memory and the integral web server.

This step, by which even small applications are now easily expandable into Internet applications, opens up many new project perspectives and extremely interesting upgrade programs. ■

**End of Saia®PCD6 production**

As advised in the previous two editions of Controls News, production of the entire Saia®PCD6 range has now ceased.

Do not worry. A repairs service will be maintained at least until the end of 2011.

For some of our customers, this represents a product lifetime for the PCD6 of more than 25 years.

Most PCD6 application programs can be transferred to a PCD5 with the Saia® PG5 programming tool. This is very useful when renovating older installations. ■

**PCD7.D202 and PCD7.D250 displays under notice**

More than 10 years after production started on the PLC-based displays PCD7.D202 and PCD7.D250, it is time to stop. Production will cease officially on 30th June 2007. Orders will be accepted up to 30th April 2007.

As usual, a repairs service will be guaranteed for a further 5 years at least, i.e. until 30th June 2012.

Saia-Burgess Controls also offers interesting replacement possibilities, e.g. the PCD7.D23x range.



**New PC software**

Package	Version	New features
Controls Suite (including PG5)	SP 1.4.120	<ul style="list-style-type: none"> <li>Support for user memory extension of PCD3.Mxxx0 CPUs with hardware version D and firmware version 030 or later (please note separate section: Incompatibility of PCD3.Mxxx0 with PG5 1.3 and PG5 1.4 in this Controls News)</li> <li>Support for PCD3.F210/F221 serial interface modules, currently in preparation</li> </ul> <p>A demo version, which is fully functional for 90 days, is available under <a href="http://www.sbc-support.ch">www.sbc-support.ch</a>. Please contact your Saia branch for any update.</p>
Controls Suite (including PG5)	SP 1.3.130	<ul style="list-style-type: none"> <li>Allows memory configuration of PCD3.Mxxx0 CPUs with hardware version D and firmware version 030 or later but, unlike PG5 1.4.120, it does not provide the added memory (please note separate section: Incompatibility of PCD3.Mxxx0 with PG5 1.3 and PG5 1.4 in this Controls News)</li> </ul> <p>We recommend an update to version 1.4.120.</p>

**New firmware**

Product	Version	New features
PCD1.M1x5	V0A7	
PCD2.Mx50	V0D3	First official version with web server
PCDx.M170	V022	LON: Support for Alias and Multiple Binding
PCS1.Cxxx	V0B4	

**New documents since Controls News 8**

Name	Document type	Document ref.	Status
Saia®DDC.Plus System	Brochure	P+P26/949	new languages available
Saia®PCD xx7 series	System Overview	P+P26/439	new
Windows® Technology for Saia®PCD	System Information	P+P26/456	new
Saia®FBox.Builder	System Information	P+P26/422	revised
Saia®S-Web-Editor	Technical Information	P+P26/453	new
Energy meter single phase	Technical Information	P+P26/433	new
Energy meter three phase	Technical Information	P+P26/436	new
Saia®Visi.Plus	Technical Information	P+P26/331	new languages available
Saia®PCD4	Technical Information	P+P26/366	revised
Saia®PCS1   DDC.Compact	Technical Information	P+P26/345	revised
Saia®PCD3.Cxxx-LIO	Technical Information	P+P26/388	revised
Building automation: Light and Shade	Application Flyer	P+P26/440	new languages available
Saia®Micro-Browser / Saia®PCD Web-Panel MB	Flyer	P+P26/435	new
Saia®DDC.Plus System catalogue	Catalogue	P+P26/215	new
Saia®PCD7.W745	Manual	P+P26/796	revised
Mobile ice rink	Reference	P+P26/954	new

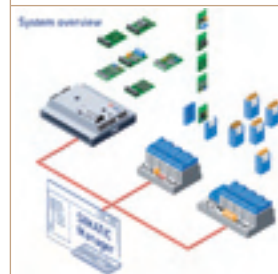

P+P26/439



P+P26/456

## Telecommunication in automation

Telecommunication is the transfer of information via public networks, such as the fixed line telephone network, Internet, GSM network, etc. There are many reasons for using telecommunications in automation. The most important is the fact that remote control systems are a convenient, economical alternative to individual trips by a specialist or service engineer. Today however, even data exchange between installations is no longer limited to local networks, as installations far away from each other often have to make their data available.

Areas of use for telecommunication

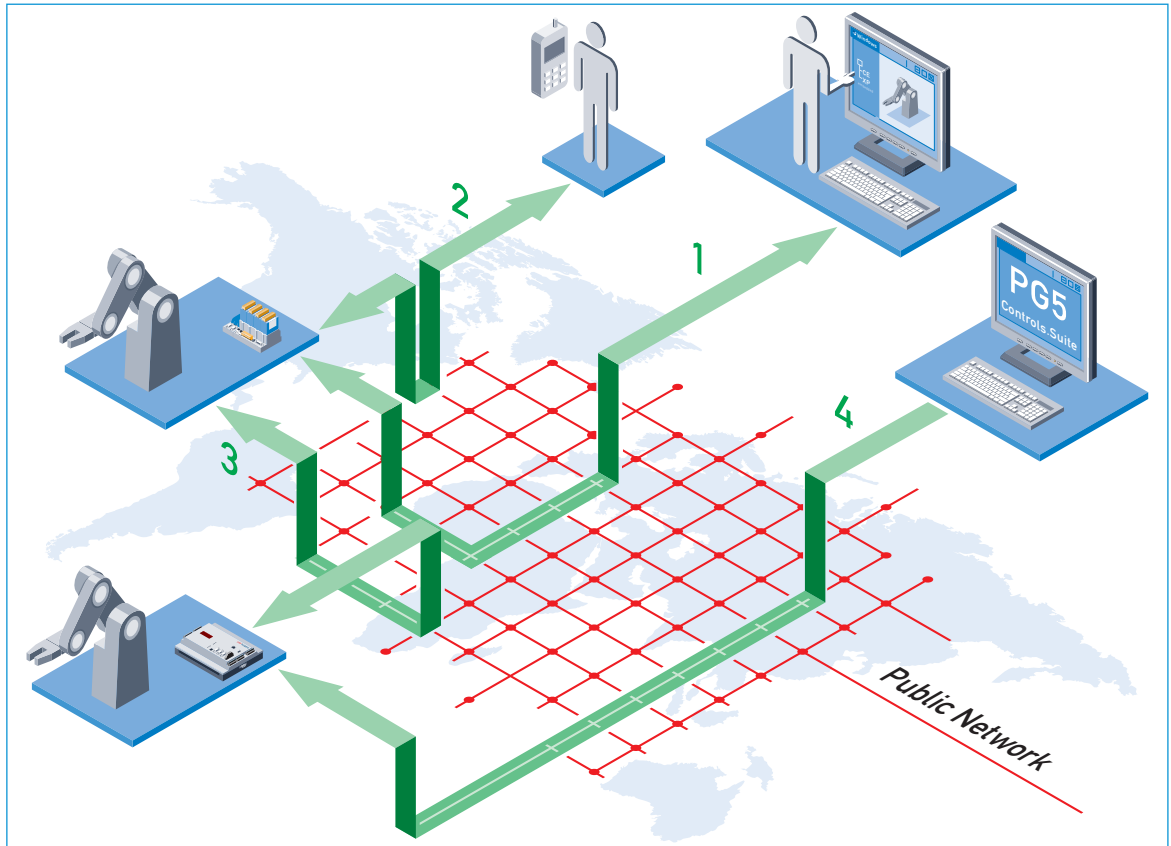

### Areas of use in automation

The main areas of use can be divided into four categories:

#### 1) Control and monitoring.

- This involves the polling of relevant information, their visualization and intervention in the system or machine.

#### 2) Event messages

- Event messages to the higher ranking management system or to service personnel.

#### 3) Exchange of data between different systems, or between an installation and a management system.

- This involves the synchronization of installations, data logging and archiving, or the transmission of a variety of configurations.

#### 4) Intervention in the function of a machine or installation, such as loading or updating the program in the Saia®PCD.

- This is done with Saia®PG5 and it makes no difference whether the system programmer is working directly on-site, or in his office.

### Technologies

In the past, telecommunication was synonymous with transmission via the public telephone network. In this case, an analogue or ISDN modem was used to establish a connection between parties. This requires the corresponding infrastructure in the system; at least one telephone connection. The triumph of mobile telephones and the GSM network has not, of course, stopped short of automation. People do not need a fixed telephone connection any more and can use them to send and receive text messages, probably the simplest and most economical option for reporting and exchanging data. GSM networks, in Europe at least, have almost 100 percent coverage of the territory. However, GSM connections are slow and, when data volumes are high, quickly result in (too) high costs.

Another kind of telecommunication, frequently called without the prefix “tele”, is access via Internet. If someone is fortunate enough to have an Ethernet connection on his installation, and if his IT department can assign a static, public IP address, there is nothing to stop access via Internet with the help of Saia®S-Connect. However, frequently this is not the case. That is when the new mobile radio technologies, like GPRS and UMTS, can provide a remedy.

**GPRS: gateway to the Internet**

Even though there are great differences between GPRS (general packet radio service) and UMTS, our focus is on GPRS, because UMTS is still not sufficiently widespread. Moreover, both transmission technologies have the same basic characteristics.

GPRS is the foundation for IP-based data transmission, i.e. target devices must understand TCP/IP and have IP addresses. GPRS always takes you into the Internet. Unlike the circuit switched data service (CSD), this involves a packet switched data service (PSD). Data is broken down into individual packets at the transmitting station and sent to the receiving station, where it is put back together. GPRS therefore involves a permanent virtual connection with the opposite station (always on). The GSM network is only used when data is transmitted, and only then are charges due. GPRS technology, by bundling all the channel's GSM time slots, allows a theoretical data rate of 171.2 kBit/s. In practice, an average throughput in operation of approx. 50 kBit/s is achieved.

Many GPRS modems and, of course, GPRS routers have an integral TCP/IP stack. However, since these IP addresses are not normally public, a route must always be chosen via a service provider. This will provide a public IP address that target devices can use for communication. In this case, the node behaves like a gateway to GPRS/Internet. Depending on the service provider, there are many ways of establishing a connection via GPRS. To list all of them and explain their small differences would go beyond the scope of this article. Examples worth mentioning are the GPRS router with VPN connection, or connection via a switching centre

In summary, GPRS has more band width than GSM and the costs are lower, because it is only necessary to pay for the volume of data actually transmitted.

**Experience with Saia®PCD and telecommunication**

Saia®PCD devices offer a variety of ways of connecting to the telecommunications network. Many factors decide whether a Saia®PCD should be accessed via a fixed network, GSM or GPRS modem, or even if the Saia®PCD can be connected directly to the Internet. Factors that play a major role are: the main

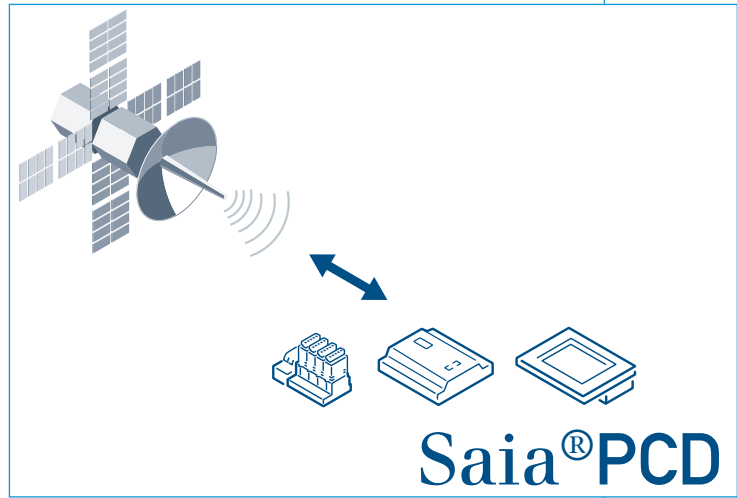

area of application (control and monitoring via web, service, diagnosis) the infrastructure available and, of course, cost. Our experience with GPRS modems and routers have shown them to be fast with http or FTP transmission, because data is streamed. They are not so well suited to connection with Saia®PG5, because the S-Bus protocol uses smaller packet sizes, and because a certain handshake takes place between the PC and the PLC.

It is also necessary to take account of required know-how and available know-how when comparing the services of individual service providers and selecting the best one. For a system integrator, it is relatively easy to obtain information about the GPRS connections, tariffs and capabilities of local providers. For an export-oriented machine builder, good local support organizations in target countries are required. It is, of course, also possible (almost always) to go via a provider in the home country. But then high roaming charges will have to be taken into consideration. ■

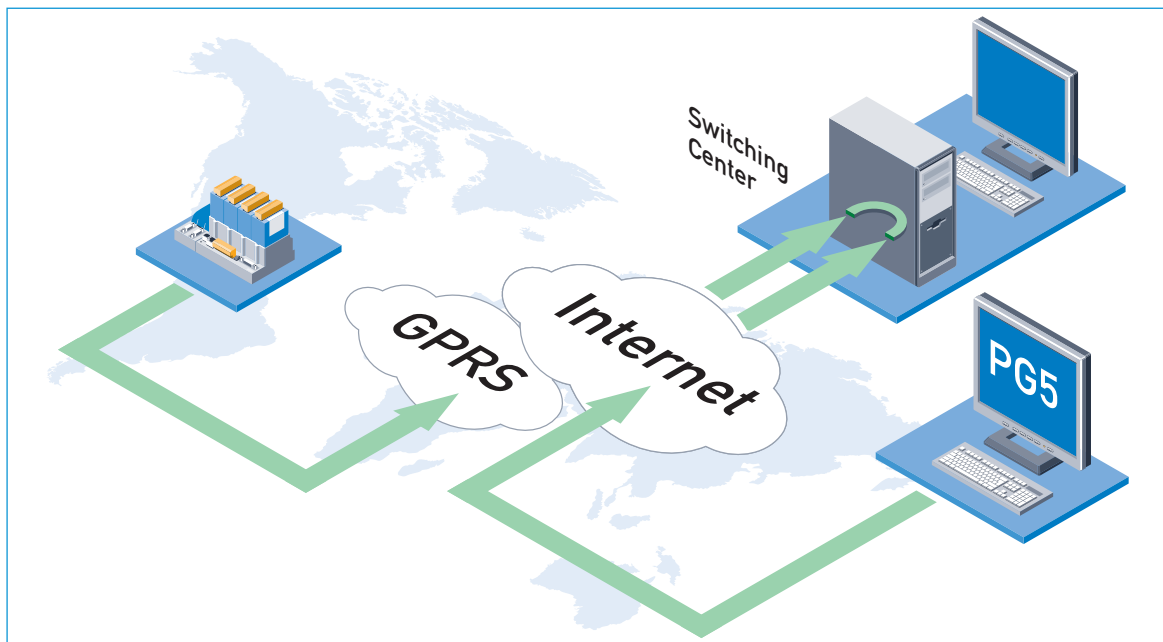

Example of a GPRS connection

# DIVISION INFO AND REFERENCE APPLICATION

## Own production area for control panels

For about 15 years, Saia-Burgess Controls has been developing and manufacturing control panels at its Murten factory in Switzerland. These mainly comprise small devices with text or semi-graphical displays and keys.



Production line for touch panels

These control panels were viewed as a natural extension of PLC/DDC controllers. Panel production was fully integrated within controller production. HMI business (HMI = human/machine interface) was not an independent unit in the organization.

Entry into Windows® CE panel business changed little in this situation. Although the CPUs for these panels are produced by Saia®, final assembly is still done by a well known, experienced, German HMI company.

Industrialization of the small, 5.7" Saia®PCD web panels has changed the production landscape in our factory substantially. For this product range, we have set up our own production

area, in order to emphasize the autonomy of HMI products from PLC /DDC controllers. But there is a "problem": in less than one year, we expect to have outgrown the new production area.

This is why we are already planning to provide more room for HMI production in 2007. We want to modernize an old part of the factory, currently used as an office building, and restate it as production space. This also gives us the possibility of paying better attention to display/touch technology with regard to equipment and infrastructure.

We are ready. You can challenge us. ■



Manual assembly of panels



**Jacques Bielmann**  
development engineer  
responsible for the new,  
small Saia®PCD web-panels



**Jonas Affolter**  
technician responsible  
for the industrialization of  
HMI products



**Monika Mai**  
responsible for display  
purchasing. She makes sure  
we get the panels' most  
important bought-in com-  
ponents at the right time, in the  
right quantity and at a good  
price from China, Taiwan or  
Japan.

## New Internet presence – www.start-controls.com



Until now, the Internet presence of the Saia-Burgess Group ([www.saia-burgess.com](http://www.saia-burgess.com)) was strongly oriented towards investors and banks within the Zurich finance market. Information had to be as broad and general as possible: understandable by anyone, even without previous knowledge. All the fields of business of the Saia-Burgess Group were represented in a uniform style, subdivided into uniform topics.

For us as specialists in controls technology, this requirement made it practically impossible to construct an attractive Internet presence for our target public.

Now that has changed. The [saia-burgess.com](http://saia-burgess.com) page will, in future, only be an entry portal to local Saia-Burgess agencies and will no longer represent the various business areas of the Saia-Burgess Group. Each area will have its own presence, oriented towards the demands of its markets.

Our new Controls presence is already online and available in 6 languages (German, English, French, Italian, Chinese and Dutch). We have given it the name: [www.start-controls.com](http://www.start-controls.com). This new Internet presence is primarily aimed at getting to know our organization, and at the pre-sales phase. It shows our autonomous corporate identity and the specific profile of Saia-Burgess Controls.

For the after-sales process, we will continue to maintain the website [www.sbc-support.ch](http://www.sbc-support.ch). Here, users will find everything they need for the installation, programming and maintenance of Saia®PCD products throughout the decades of the life cycle of a PLC-based automation system.

### Link up with us!

We would be happy for you to include a link to our new [www.start-controls.com](http://www.start-controls.com) site from your own website. You will find instructions for this – and attractive banners – under <http://www.start-controls.com/banner.html> ■



# China and Controls?

Relax! We have not caught the "euphoria virus" regarding China. However, over the past year we have rationally assessed the importance of China for ourselves, and made some appropriate decisions about our activities there.

China is important for us today in three ways:

- **Sales market for our OEM customers in machine building**  
We provide these with local, technical support and supply them with products. Technical documentation in Chinese for Saia®PCD controller technology helps our customers sell their own products better in China, and assists them in training a local support organization.
- **Sales market for our Saia®DDC.Plus portfolio for infrastructure automation**  
The automation level, with its diverse requirements for communications/programming and visualization, has a high value in China too. Using local suppliers to build onto the overall system offered is very difficult and timeconsuming. So, in China, we find a similar competitive environment to that in Europe. By acting in the same way that has delivered success here, we will also have good opportunities in China.
- **Procurement market**  
With high-volume products like the Saia®Controls.Components, we are in a toughly contested market, where every cent counts. For higher value parts, like displays, the price level in China and Taiwan is the lowest in the world. For simple, ready-assembled subsystems, it is hard to beat China on price – and recently also on quality. These are important arguments for us in favour of being capable of local procurement in China.



● Our presence in China

In the medium term, we also want to gain local Chinese and Taiwanese OEM customers, not just look after the Chinese transplants of European OEM customers. Our strategy involves a mix of core products/core components, which we manufacture in our Swiss plant and combine with locally developed and produced parts to form an attractive package, both on price and technology. ■

## Expansion of basic structure

In view of this importance, we have invested in building a basic structure. The head office of our activities in China is located in Shenzhen, close to Hong Kong, where we are well placed to deal with Taiwan too. We also have technical sales personnel in Dalian, Xian und Shanghai.

As the legal basis for our activities, Saia-Burgess Controls (Shenzhen) was recently set up. For China, this is a new type of foreign controlled company. Previously it was normal for production to take place in China, but there was no possibility of selling or importation.

Saia-Burgess Controls is one of the first foreign companies whose purpose also includes importation and local sales of goods. Accordingly, we can also declare value added tax. This makes Saia®PCD and Saia®CC products cheaper locally than before. This is crucial for success in such a price-sensitive market.



Team Saia-Burgess Controls, Shenzhen, China

## Exhibitions/Trade fairs



28. 11 – 30. 11. 2006  
SPS Drives,  
Nürnberg, Germany  
Hall 7, Booth 7-494

5. – 8. 12. 2006  
SCS Automation & Control,  
Paris, France  
Hall 5A, Booth L47

6. – 10. 3. 2007  
ISH,  
Frankfurt, Germany  
Hall 10.2, Booth B43

16. – 20. 4. 2007  
Hannover Messe  
Industry (HMI),  
Hannover, Germany



Chinese Saia®PCD documentation

## Imprint

Controls News is published twice yearly in four language versions: German, French, English, Italian

### Publisher

Saia-Burgess Controls Ltd, Bahnhofstrasse 18, CH-3280 Murten  
Tel.: +41 26 672 71 11 | Fax: +41 26 672 74 99 | www.start-controls.com | pcd@saia-burgess.com

### Responsible for English edition

Patrick Marti, Saia-Burgess Controls Ltd

### Editorial team

Jürgen Lauber, Patrick Marti, Sandra Hofer, Claude Affolter, Simon Ginsburg, Christoph Graessner, Jürg Hurni, Urs Jäggi, Kostantinos Kafandaris, Joachim Krusch, Robert Scheiwiller, Peter Steib, Wilfried Schmidt; Saia-Burgess Controls Ltd, Trond Olsen; Malthe Winje Automation, Norway.

### Conception, design and production

Sandra Hofer, Saia-Burgess Controls Ltd

# “Freedom of the Seas” – the world’s biggest cruise ship is equipped with Saia®PCD3

The “Freedom of the Seas” is Royal Caribbean International’s most innovative ship yet. It was built at Aker Finnyards in Turku, Finland, in association with the Chantiers de l’Atlantique (France). The Freedom of the Seas counts as the world’s biggest cruise ship, just 6 m shorter than the Queen Mary II but 10,000 tons heavier. Since June 2006, it has been in operation in the Caribbean. Its sister ship, the Liberty of the Seas was launched in September, and a second sister ship will be launched in early 2008.



- Physical data:
- Length: 339m
  - Height: 64m
  - Width: 44m
  - Weight: 160 000 tons
  - No. of passengers: 4375, crew 1365.
  - 18 decks.
  - 6x V12 engines with 25'000 Hp each.
  - 3 propellers (2 can be turned through 360°)
  - The diesel engines generate 11 KV distributed to the power grid.

Autronica’s Fire and Security system relies on Saia®PCD for the comfort and security of the 5740 passengers and crew on board this cruise ship of the superlatives.

Today’s large cruise liners include more and more technical features for the comfort and safety of passengers and must be built within the shortest possible time. The quality of the products selected for shipbuilding and the flexibility of the concepts used are the most important requirements in projects of this type.

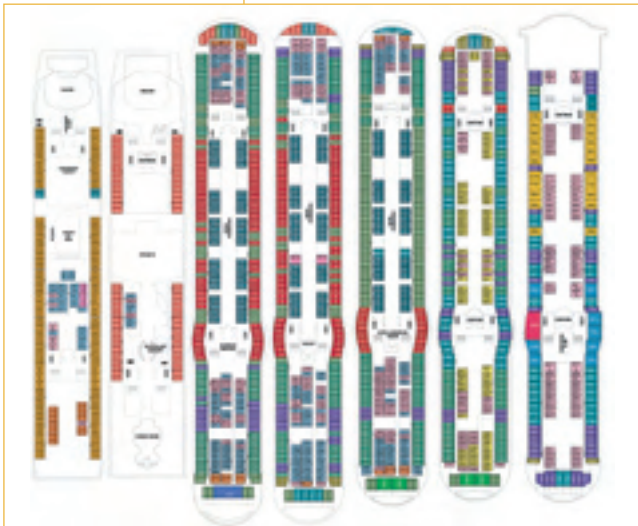

The design of fire and security systems is no exception and Autronica, as an expert in this field, has a strong reputation for innovation and reliability. It was therefore a very natural decision to use Saia®PCD5, the newest controller family from Saia-Burgess Controls, to fulfill so elegantly the design specifications for reliability and communication capability.

The move from PCD2 to PCD5 allowed Autronica to make significant improvements in their safety concept, simplifying the design and improving the performance. Both are important advantages that every customer expects from their key supplier.

## The Autronica Fire & Security based system

The fire detection and security system covers all areas of the ship. Thousands of data points are permanently monitored and alarms transmitted within the shortest possible time to the bridge. A demanding task, all around the clock, managed by networks of Saia®PCD5 for each of the several 1000 cabins, recreational areas, staff areas and technical rooms.

The 3 workstations on the bridge and the one in the electronic control room (ECR) collect information from 7 fire centres (BS-100) with a total of 6050 addresses (smoke detectors and alarm sensors) distributed on 85 separate loops. The interface with MMC control is via Modbus (indication of fire dampers and fans). Modbus communication also interfaces a data-logging system for all objects connected to the system.

The installation contains over 2000 I/Os for the control of 1000 fire doors, 240 low location lights and 100 sprinkler valves. All I/Os are distributed to 110 PCD5.T760 and 7 PCD5.M5540 devices in the fire zones. An additional PCD5.M5540 is located in every fire zone, which communicates with the T760s. The PCD5.M5540s are connected via Ethernet in a multi-master system.



## Communication

Redundant communication ensures full control of every fire security zone at all times, whether through desk-top operating station or through one in the ECR room. Since the PCD5 can manage several networks simultaneously, this kind of communication solution is easily engineered.

The 4 graphical stations are connected together in a separate network. A control command (e.g. open/close fire door) from one station is replicated to the other ones. These will send the command to both the bridge and the ECR PLC. The bridge PLC sends the command to zone 1 via Ethernet and, in parallel, the command is sent from the ECR PLC to the zone PLC. After that the command is sent to the correct RIO station. A cable break does not affect the command, because it is always sent in parallel. This means that any failures can be located immediately, without loss of communication.

For a short, virtual tour on-board, go to: <http://www.freedomoftheseas.com/> ■



# LOCAL NEWS INTERNATIONAL

## Inter plant system solution at FloraHolland; for control and monitoring all building technology facilities



In recent years, the FloraHolland flower auction in Naaldwijk has greatly expanded its automation and technical installations. A building automation system, based on over 140 Saia®PCD2 controllers, has been installed by Regel Partners, a system integrator from Hoevelaken. This project is remarkable not only because of its huge scale (one cooling cell alone measures as much as 5 football fields!) but also because it integrates such a wide variety of technical installations. These include chilled and hot water production, HVAC systems, lighting systems, E-systems, security systems, sprinkler systems, alarm handling, door control and energy monitoring.



Regel Partners installed Saia®PCD2.M170 as the controller, combined with iFix SCADA for visualization and management. Within this one system, a high level of integration enables many tasks to be executed and managed with one push of a button. In the past, approximately 900 (!) lighting groups had to be switched manually!

During the coming 6 months, Regel Partners will install another 40 PCD2.M170 controllers, mainly for the renovation of HVAC systems.

Another benefit is the added saving in gas and electricity costs, due to the implementation of peak use software ("penalty prevention"). ■

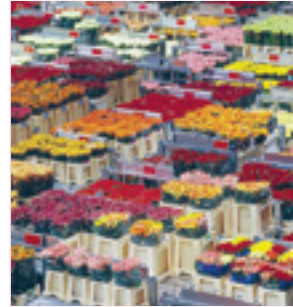

The flower auction can best be described as a giant covered market of 759 000 m<sup>2</sup>. Every day, over 8000 people come to work here: buying, selling, packaging, handling and transporting plants and flowers.

### What makes this automation project so special?

The infrastructure includes a redundant glass fiber circuit throughout the whole building. This circuit ensures that, in case of a breakdown, the system will find its own way to the users. A 100 mB full duplex fiber cable contains 32 fibers for the control of building management, infrastructure automation and security with CCTV.

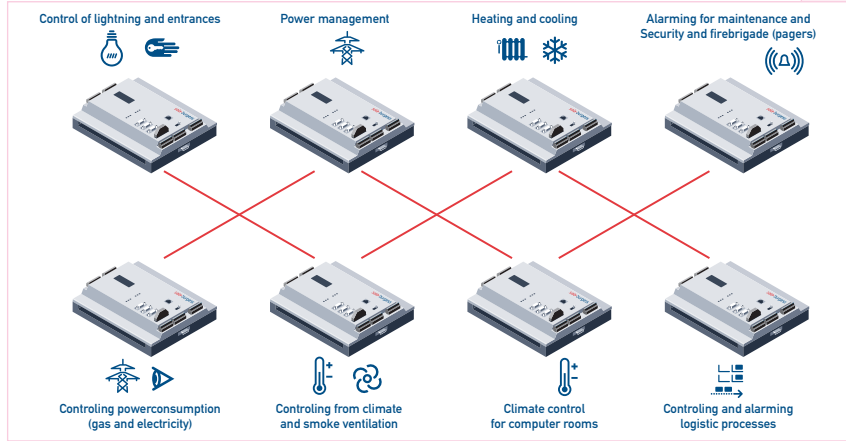

A total of 140 CPUs PCD2.M170. All conected through separate Ethernet for building automation

## Production of Bio-Energy by Saia®PCD Dordtech

Dordtech Engineering B.V. develops and supplies power plants using alternative fuels, such as bio gas or bio oil. These power plants can be supplied as standard generator sets and expanded as required to form CHP installations, with or without the production of steam etc.

Generators can, if necessary, also be provided with an exhaust fume converter, tanks for fuel or urea, and remote monitoring.

All the information needed to control the installation is contained within a Saia®PCD. From this PCD, all commu-

nication data is sent to the main office of Dordtech Engineering B.V. in Dordrecht, where every installation, no matter where, can not only be monitored but also controlled.

The installation in Zaltbommel comprises a 500kW generator set that runs on refined palm oil. This CHP plant is controlled by a Saia®PCD2.M480 and a Vario Plus CHP controller. The heat produced by the installation is used in the glass house and the electricity generated is supplied to the grid. ■



### Extension of our presence in China

In order to continue along the business path of SBC Shenzhen, China, our fully licensed commercial subsidiary, we extended our team with three new people: Mr KK. Wu, Mrs Vicky Ma and Mrs Maggie Wu.

We are very proud to welcome Mr. K.K. Wu as Saia®DDC Plus sales manager. The long experience of Mr Wu in the field of building automation represents a huge potential of development for our existing system integrators and for the new ones joining our community.

They have now access to a Saia-Burgess Controls partner within China able to consistently help them to optimize their offering for building control and infrastructure automation.

Vicky Ma's focus is commercial customer service. She takes care of inquiries, order processing and confirmation of order. Maggie Wu is focussing in marketing, translation of documents, management of internet and organization of customer events. They will both support the Technical Service (TS) team, lead by Gray Yang. Our young and dynamic team is actively developing our presence in China. ■

思博控制深圳有限公司  
 深圳市福田区竹子林求是大厦东座 1513号, 邮编 518040  
 Saia-Burgess Controls Shenzhen Limited  
 Qiushi Center E1513, Zhuzilin, Futian District, Shenzhen, P R China  
 TEL +86 [0]755 8831 6043 | FAX +86 [0]755 8831 6041 | www.saia-burgess.cn



### A PCD3.M3330 network equips the newest road tunnel of Katowice (Poland)



A new road tunnel of 650 meters is going to be opened to the traffic early 2007 in the city of Katowice, Poland. The Saia®PCD3 based system supervises and controls all tunnel's vital installations, i.e. tunnel ventilation, tunnel lighting, traffic information and display system, air quality measurement and alarms and the HVAC of the control room. All this is controlled by a network of 60 PCD3.M3330 CPU with 1000 digital I/Os and 320 analogue I/Os. ■

### Large district heating project with Saia®PCD3 in Bucharest (Romania)



Bucharest has the second and most important district heating system in Europe. The actual modernization program is crucial in order to increase the energy efficiency and to reduce the heat consumption through active saving measures in the existing thermal stations serving block of flats.

Fela Planung AG, a Swiss system integrator, won the project for the modernization and automatic control of over 450 district heating stations in Bucharest and chose Saia®PCD3 for the automation.

RADET (Regia Autonoma de Distributie a Energiei Termice Bucuresti) the company managing the district heating network, selected the newest and competitive technologies from Saia-Burgess Controls in combination with the application expertise of Fela Planung.

The core of each station is a PCD3.M5540, bringing the necessary concept modernity, flexibility and reliability to fulfill all the demands specified in the tender.

The PCD deliveries worth over 1 million CHF will be done within the next twelve months. ■

Saia®PCDs are used successfully since years in district heating project all around Europe.

### Saia®PCD trainings in Argentina and Brazil

Just before the summer holidays, Saia-Burgess Controls organized trainings and workshop with our national distributors Murten srl in Argentina and Dakol Ltda in Brazil. We also met with OEMs and system integrators. It was an occasion not only to train many interested people on our latest products and software tools, but also to share ideas, concept solutions and objectives for the future.



A good way to continue our Saia®PCD tradition in South America. ■

### Saia-Burgess Controls Ltd

Bahnhofstrasse 18 | CH-3280 Murten | Switzerland  
 T +41 26 672 71 11 | F +41 26 672 74 99  
 www.start-controls.com | pcd@saia-burgess.com