

EEM230-D-M

Electrical Energy Meter with integrated M-Bus interface

Electrical energy meter with an integrated M-Bus interface allow direct reading of all relevant data, such as energy (total and partial), current, voltage, active and reactive power.

MAIN FEATURES:

- Single-phase energy meter, 230 VAC 50 Hz
- Direct measurement up to 32 A
- Display of active power, voltage and current
- M-Bus interface to query the data
- Reactive power available through interface
- Up to 250 meter can be connected to the M-Bus interface
- 7-digit display
- Lead seal possible with cap as accessory
- Accuracy class B according to EN50470-3, accuracy class 1 according to IEC62053-21



Order Number

Standard Version: **EEM230-D-M**
MID Version: **EEM230-D-M-MID**
Sealing caps: **EEM230-SEALCAP**
(Bulk with 20 units)

TECHNICAL DATA	
PRECISION CLASS	B according to EN50470-3, 1 according to IEC62053-21
OPERATING VOLTAGE	230 VAC, 50 Hz Tolerance -20 % / +15 %
REFERENCE/ MEASUREMENT CURRENT	$I_{ref} = 5 \text{ A} / I_{max} = 32 \text{ A}$
STARTING/MINIMUM CURRENT	$I_{st} = 20 \text{ mA} / I_{min} = 0.25 \text{ A}$
POWER CONSUMPTION	Active 0.4 W per phase
COUNTING RANGE	00000.00...99999.99 100000.0...999999.9
DISPLAY	LCD backlit, digits 5 mm high
PULSES PER KWH	LC-Display 2000 Imp./kWh

MOUNTING	
MOUNTING	On 35 mm rail, according to EN60715TH35
TERMINAL CONNECTIONS MAIN CIRCUIT	Conductor cross-section max. 6 mm ² , screwdriver pozidrive no. 1, slot no.1 torque: 1.2 Nm
TERMINAL CONNECTIONS CONTROL CIRCUIT	Conductor cross-section max. 2.5 mm ² , screwdriver pozidrive no. 0, slot no.1 torque: 0.5 Nm
INSULATION CHARACTERISTICS	4 kV/50 Hz test according to VDE 0435 for energy meter part 6 kV 1.2/50 μs surge voltage according to IEC255-4 2 kV / 50 Hz test according to VDE 0435 for Interface Device protection class II
AMBIENT TEMPERATURE	-25 °...+55 °C
STORAGE TEMPERATURE	-30 °...+85 °C
RELATIVE HUMIDITY	75 % without condensation
ENVIRONMENT	Mechanical M2 Electromagnetic E2
EMC/INTERFERENCE IMMUNITY	Surge voltage according to IEC61000-4-5 at main circuit, 4 kV at M-Bus interface, 1 kV Burst voltage according to IEC61000-4-4, at main circuit 4 kV at M-Bus interface 1 kV ESD according to IEC61000-4-2, contact 8 kV, air 15 kV

DIMENSION DIAGRAM

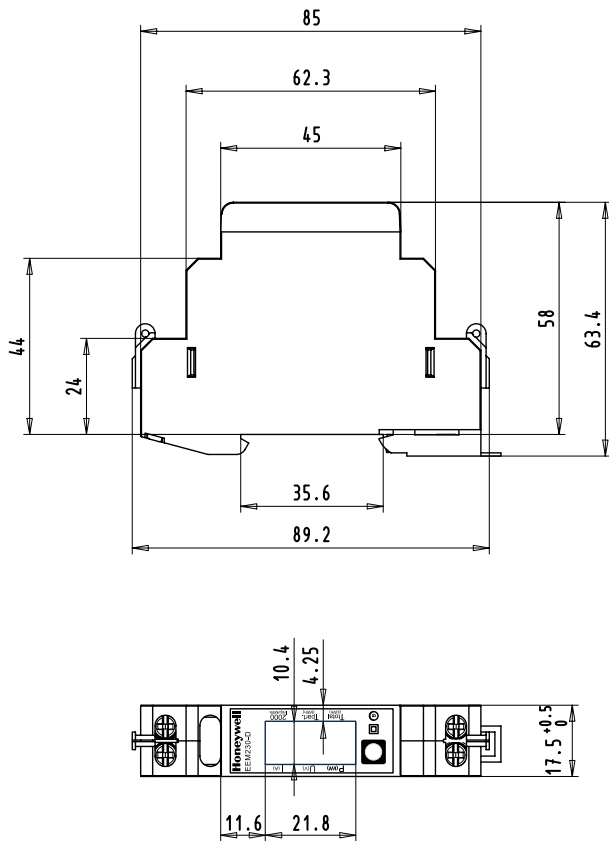

DISPLAY ELEMENTS, DIRECT MEASUREMENT

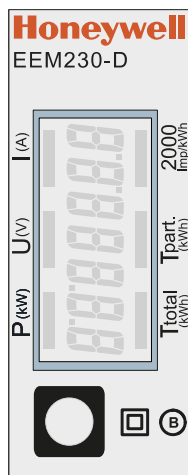

- T total (kWh) Indicates the total consumption
- T part. (kWh) Indicates the partial consumption. This value can be reset
- P (kW) Indicates the instantaneous power
- U (V) Indicates the voltage
- I (A) Indicates the current
- 2000 pulses/kWh Pulsates according to the amount of used power.
Error indication (Line 1L/2L inverted) pulsating with 600/600 ms

WIRINGS DIAGRAM

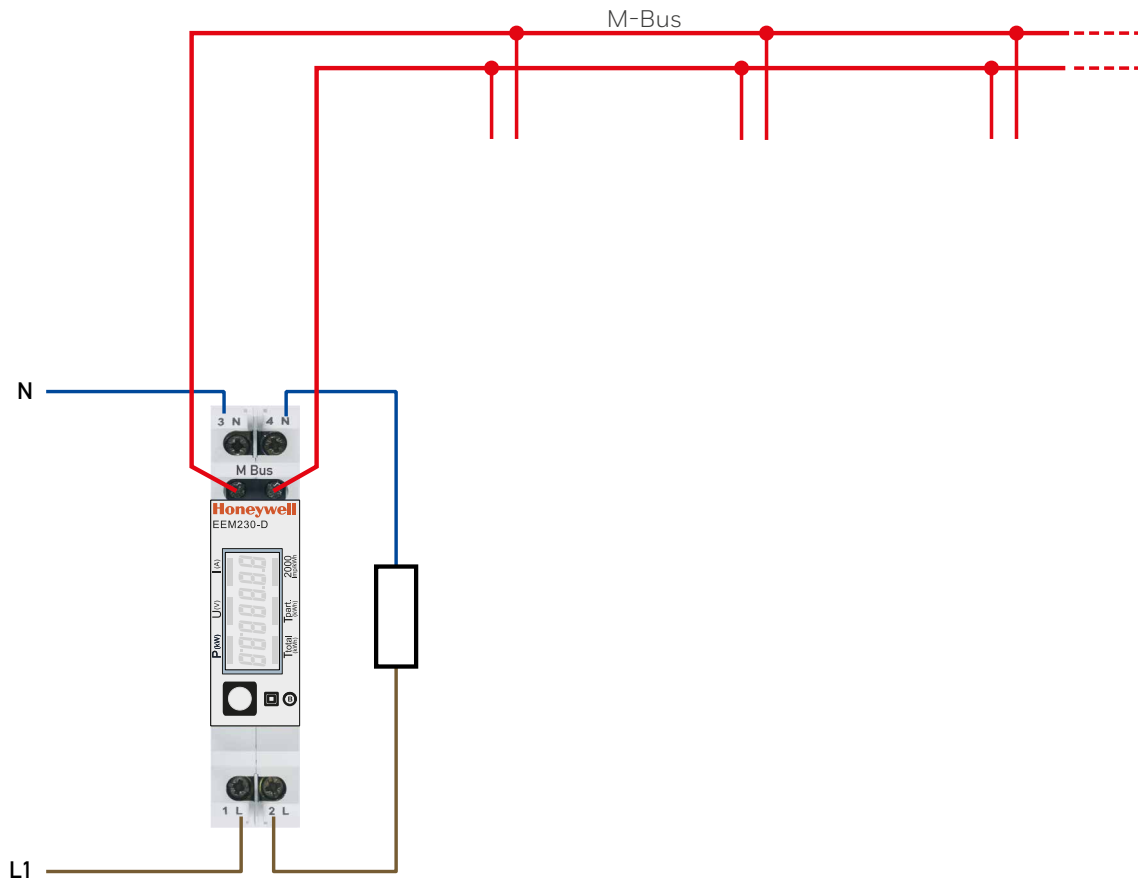

FW VERSIONS

In autumn 2016, a new FW version was launched. As of firmware version 1.3.3.6, the setting of the baud rate changes.

- The baud rate is no longer automatically detected, it has to be changed using the two keys and the LC display (see pages 5).
- The baud rate can be changed using a M-Bus telegram (see pages 7).

Menu to display the values on the LCD

Up to versions FW1.3.3.5

T total
Total consumption

Start

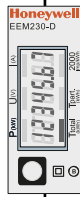

Tpart.
Partial consumption

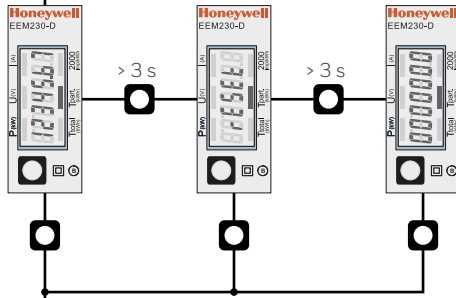

P
Instantaneous power

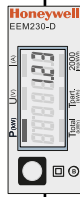

U
Voltage

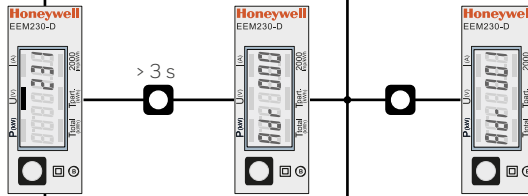

I
Current

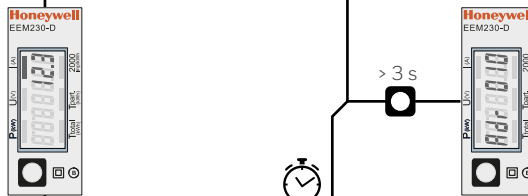

Back to Start

Back to Start

Menu to display the values on the LCD

Starting with version FW1.3.3.6

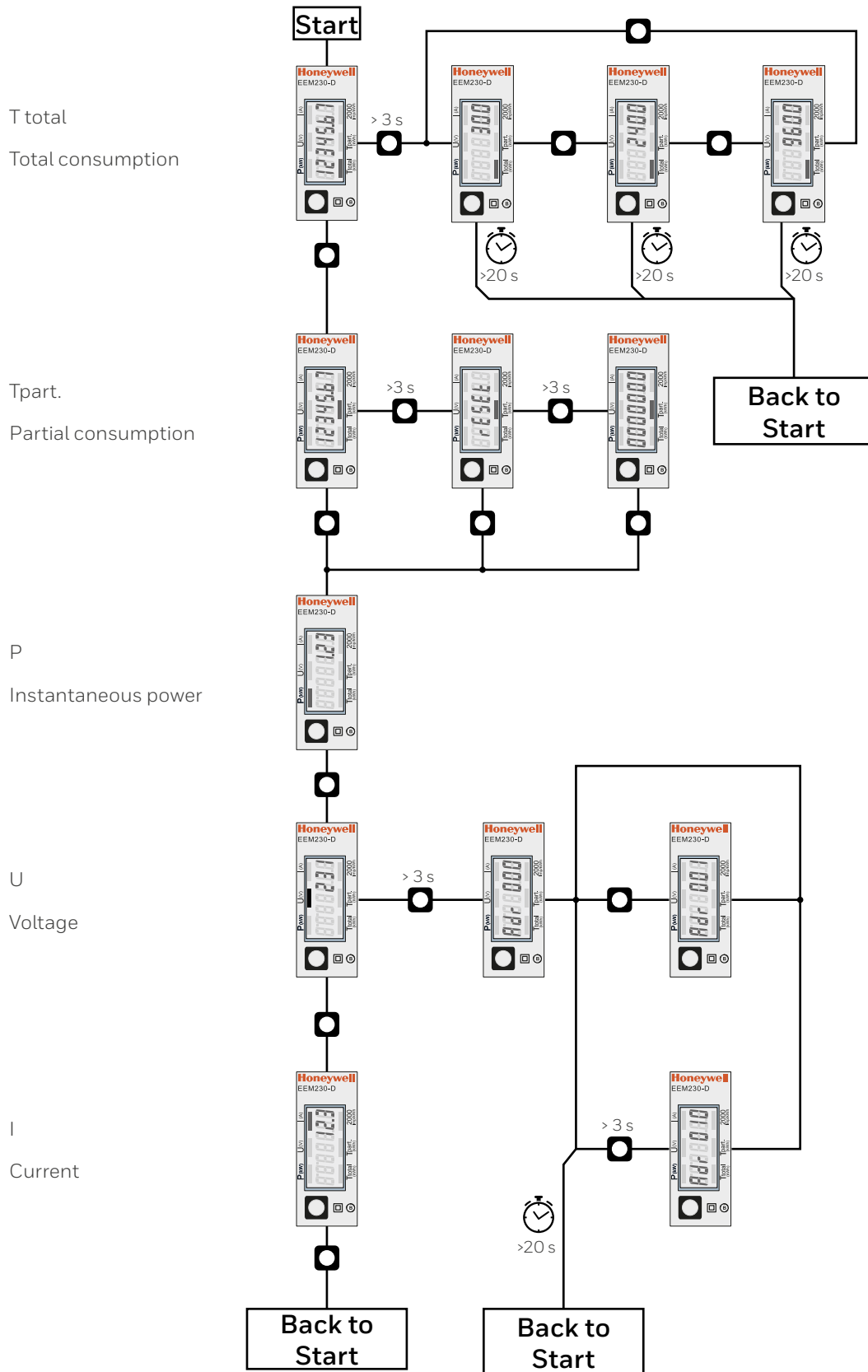

Data M-Bus

Up to versions FW1.3.3.5

TECHNICAL DATA M-BUS	
BUS SYSTEM	M-Bus
BUS LENGTH	According to M-Bus specification
TRANSMISSION RATES	300, 2400, 9600 Bd. The transmission rate is automatically detected
RESPONSE TIME: (SYSTEM RESPONSE)	Write up to 60 ms Read up to 60 ms

Data transfer

- ▶ When reading out the values, all values are transferred in a telegram
- ▶ It supports the following telegrams (see p.6 for more detailed information):
 - Initialisation SND_NKE Response: 0xE5
 - Reading meter REQ_UD2 Response: RSP_UD
 - Changing primary address SND_UD Response: 0xE5
 - Reset T_{part} SND_UD Response: 0xE5
- ▶ The device does not respond to unknown queries
- ▶ The transmission rate is automatically detected
- ▶ The device has a voltage monitor. In the case of a power failure, all the registers are saved in the EEPROM.

Change the M-Bus address direct on device

- ▶ In the menu, go for «U»
- ▶ Push long (≥ 3 sec) “MBUS-ADR”
- ▶ Push short M-Bus address +1, push long M-Bus address +10
- ▶ Once the desired address is selected wait, to validate, till the root menu to come back

Secondary addressing

- ▶ It is possible to communicate with the energy meter using the secondary address, according to EN13757
- ▶ The use of Wild Cards is possible

Data M-Bus

Starting with version FW1.3.3.6

TECHNICAL DATA M-BUS	
BUS SYSTEM	M-Bus
STANDARD	EN13757
BUS LENGTH	According to M-Bus specification
TRANSMISSION RATES	300, 2400, 9600 Bd. (factory setting: 2400 Bd). The transmission rate can be changed via display/M-Bus.
RESPONSE TIME: (SYSTEM RESPONSE)	Write up to 60 ms Read up to 60 ms

Data transfer

- ▶ When reading out the values, all values are transferred in a telegram
- ▶ It supports the following telegrams (see p.6 for more detailed information):
 - Initialisation SND_NKE Response: 0xE5 (ACK)
 - Reading meter REQ_UD2 Response: RSP_UD
 - Changing primary address SND_UD Response: 0xE5 (ACK)
 - Reset T_{part} SND_UD Response: 0xE5 (ACK)
 - Slave selection for secondary addressing SND_UD Response: 0xE5 (ACK)
 - The transmission rate is changeable SND_UD Response: 0xE5 (ACK)
- ▶ The device does not respond to unknown queries
- ▶ The device has a voltage monitor. In the case of a power failure, all the registers are saved in the EEPROM.

Change the M-Bus address direct on device

- ▶ In the menu, go for «U»
- ▶ Push long (≥ 3 sec) «Adr ...»
- ▶ In the following menu: push short M-Bus address +1,
push long M-Bus address +10
- ▶ When the desired address is set, wait until the main display appears again.

Secondary addressing

- ▶ It is possible to communicate with the energy meter using the secondary address, according to EN13757
- ▶ The use of Wild Cards is possible

Changing the baud rate

Variant 1 (local keys and LCD):

- ▶ In order to change the M-Bus baud rate, hold down touch for 3 sec
- ▶ In the following menu, changes the baud rate from 300 to 9600 baud and 2400
- ▶ When the desired M-Bus baud rate is set, wait until the main display appears again

Variant 2 (using M-Bus):

- ▶ Send: 9600 → Telegram: 0x68 0x03 0x03 0x68 0x43 <addr> 0xBD <cs> 0x16
2400 → Telegram: 0x68 0x03 0x03 0x68 0x43 <addr> 0xBB <cs> 0x16
300 → Telegram: 0x68 0x03 0x03 0x68 0x43 <addr> 0xB8 <cs> 0x16
- ▶ Response: 0xE5 (sent with the former baud rate)
- ▶ A M-Bus master must communicate within 10 minutes to the M-Bus slave on the new baud rate to validate and save the baud rate change permanent (EN13757-3).

Value information field (VIF)

Provides information on multiplier and the unit of the following data block

Value information field extension (VIFE)

Detailed information on multiplier and the unit of the following data block

Data information field (DIF)

Specifies how the data should be interpreted by the master in terms of length and encoding

Data information field extension (DIFE)

Provides information on the tariff or subunits of the following data block

Reading meter

Query: REQ_UD2

Response: RSP_UD (see Telegram structure)

TELEGRAM STRUCTURE										
0x68	0x38	0x38	0x68	0x08	PAdr	0x72	ID	0xEE	0x21	DEV
02	ACC	STAT	0	0	0x8C	0x10	0x04	Eto	0x8C	0x11
0x04	Epa	0x02	0xFD	0xC9	0xFF	0x01	V	0x02	0xFD	0xDB
0xFF	0x01	I	0x02	0xAC	0xFF	0x01	P	0x82	0x40	0xAC
0xFF	0x01	Pr	Csum	0x16						
Constantes		Variable à 1 octet			Variable à 2 octets			Variable à 4 octets		

BYTE	CONTENT	TYPE	DESCRIPTION
23 - 26	Eto=x	4 b. BCD	Energy total
30 - 33	Epa=x	4 b. BCD	Energy partial
39 - 40	V=x	2b. Integer	Voltage
46 - 47	I=x	2b. Integer	Current
52 - 53	P=x	2b. Integer	Power
59 - 60	Pr=x	2b. Integer	Reactive Power

UNIT WITH MULTIPLIER			
I	(Current)	0.1	[A]
U	(Voltage)	1	[V]
P _{ACTIVE}	(Power)	0.01	[kW]
P _{REACTIVE}	(Reactive Power)	0.01	[kVA _r]
E	(Consumption)	0.01	[kWh]

Telegram structure (detailed)

BYTE	VALUE	DESCRIPTION
1	0x68	Start
2	0x38	L_Read
3	0x38	L_Read
4	0x68	Start
5	0x08	C
6	x	Primary address
7	0x72	CI
8	x	ID1 (LSB)
9	x	ID2
10	x	ID3
11	x	ID4 (MSB)
12	0xEE	MAN1
13	0x21	MAN2
14	x	DEV (Typ - Version)
15	02	MED (Electric)
16	x	ACC
17	see footnote*	STAT
18	0	SIG1
19	0	SIG2
20	0x8C	DIF
21	0x10	DIFE
22	0x04	VIF = 0.01 kWh
23	Eto_4	T1 total
24	Eto_3	
25	Eto_2	
26	Eto_1	
27	0x8C	DIF
28	0x11	DIFE
29	0x04	VIF = 0.01 kWh

BYTE	VALUE	DESCRIPTION
30	Epa_4	T1 Partial
31	Epa_3	
32	Epa_2	
33	Epa_1	
34	0x02	DIF
35	0xFD	VIF
36	0xC9	VIFE = 1V
37	0xFF	VIFE
38	0x01	VIFE
39	V_2	Voltage
40	V_1	
41	0x02	DIF
42	0xFD	VIF
43	0xDB	VIFE = 0.1 A
44	0xFF	VIFE
45	0x01	VIFE
46	L_2	Current
47	L_1	
48	0x02	DIF
49	0xAC	VIF = 0.01kW
50	0xFF	VIFE
51	0x01	VIFE
52	P_2	Power
53	P_1	
54	0x82	DIF
55	0x40	DIFE
56	0xAC	VIF = 0.01kVAr
57	0xFF	VIFE
58	0x01	VIFE
59	Pr_2	Reactive power
60	Pr_1	
61	CS	Checksum
62	0x16	Stop

* footnote

BYTE	BIT	VALUE	NAME	DESCRIPTION	STANDARD
17			STAT	Status register	
	0	b'xxxx xxx0'	Application_busy	Unused, is always 0	M-Bus
	1	b'xxxx xx1x'	Any_Application_Error	This bit is set when the internal communication is not working	M-Bus
	2	b'xxxx x0xx'	Power_low	Unused, is always 0	M-Bus
	3	b'xxxx 1xxx'	Permanent_Error	This bit is set when the counter type could not be found in the frame of the initialization	M-Bus
	4	b'xxx1 xxxx'	Temporary_Error	This bit is set during initialization phase and will be reset when all values have been read out once successfully. While this bit is set, the RSP_UD telegram contains no values	M-Bus
	5	b'xx1x xxxx'	Internal data refresh not ready	This bit is set as long as the internal communication is interrupted by other process	Defined by SBC
	6 and 7	b'00xx xxxx'	not defined	Unused, they are always 0	Unused

Initialisation

Query: SND-NKE Response: 0xE5

Telegram structure (brief)

0x10	0x40	Padr	Csum	0x16
------	------	------	------	------

Telegram structure (detailed)

BYTE	VALUE	DESCRIPTION
1	0x10	Start
2	0x40	Send or reply, reset
3		Primary address
4		Checksum
5	0x16	Stop

Reset ACC (application reset)

Query: SND-UD Response: 0xE5

Telegram structure (brief)

0x68	0x03	0x03	0x68	0x53	Padr
0x50	Csum	0x16			

Telegram structure (detailed)

BYTE	VALUE	DESCRIPTION
1	0x68	Start
2	0x03	Field length
3	0x03	Field length
4	0x68	Start
5	0x53	C
6		Primary address
7	0x50	CI
8		Checksum
9	0x16	Stop

Changing primary address

Query: SND-UD
(Byte 6 = actual M-Bus address; Byte 10 = new address)

Response: 0xE5

Telegram structure (brief)

0x68	0x06	0x06	0x68	0x53	Padr
0x51	0x01	0x7A	New A	Csum	0x16

Telegram structure (detailed)

BYTE	VALUE	DESCRIPTION
1	0x68	Start
2	0x06	Field length
3	0x06	Field length
4	0x68	Start
5	0x53	C
6		Primary address
7	0x51	CI
8	0x01	DIF
9	0x7A	VIF
10		New address
11		Checksum
12	0x16	Stop

Reset T_{part}

(Application reset with subcode)

Query: SND-UD
(Reset Counter: 0x01 = T1Part)

Response: 0xE5

Telegram structure (brief)

0x68	0x04	0x04	0x68	0x53	Padr
0x50	0x01	Csum	0x16		

Telegram structure (detailed)

BYTE	VALUE	DESCRIPTION
1	0x68	Start
2	0x04	Field length
3	0x04	Field length
4	0x68	Start
5	0x53	C
6		Primary address
7	0x50	CI
8	0x01	Reset Counter T1Part
11		Checksum
12	0x16	Stop

Secondary address

Query: SND-UD Response: 0xE5

Telegram structure (brief)

0x68	0x0B	0x0B	0x68	0x53	FD
0x52	ID1	ID2	ID3	ID4	MAN1
MAN2	DEV	MED	Csum	0x616	

Telegram structure (detailed)

BYTE	VALUE	DESCRIPTION
1	0x68	Start
2	0x0B	Field length
3	0x0B	Field length
4	0x68	Start
5	0x53	C
6	0xFD	Address selection for secondary addressing
7	0x52	CI
8	ID1	ID1
9	ID2	ID2
10	ID3	ID3
11	ID4	ID4
12	MAN1	MAN1
13	MAN2	MAN2
14	DEV	DEV
15	MED	MED
16	Csum	Csum
17	0x16	Stop

ACCESSORIES

ORDER NO.

Sealing cover for single-phase Honeywell energy meter EEM230

EEM230-SEALCAP

2 units are recommended for contact protection.



EEM230 with assembled sealing cover



EAC Mark of Conformity for Machinery Exports to Russia, Kazakhstan or Belarus.

Manufactured for and on behalf of the Environmental and Combustion Controls Division of Honeywell Technologies Sàrl, Rolle, Z.A. La Pièce 16, Switzerland by its Authorized Representative:

For more information

support@saia-pcd.com | www.sbc-support.com

Saia-Burgess Controls AG

Bahnhofstrasse 18

3280 Murten, Switzerland

T +41 26 580 30 00 | F +41 26 580 34 99

www.saia-pcd.com

Subjects to change without notice

® U.S. Registered Trademark

© 2018 Honeywell International Inc.

PP26-587 | Rev. ENG04 | 08/2018

© 2018 Honeywell International Inc.

Honeywell