

Industrial ETHERNET Rail Switch

Q.NET-5TX

Q.NET-8TX

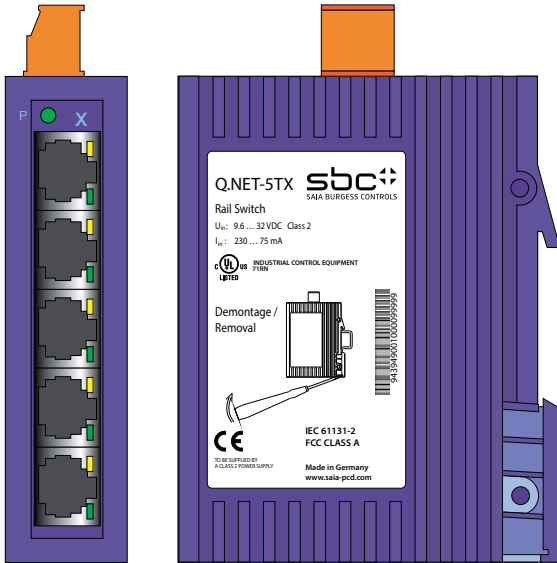

The Rail Switch / media converter Q.NET-5TX, is a switch especially designed for use in industrial environments. It supports ETHERNET 10 MBit/s and Fast ETHERNET 100 MBit/s.

The Q.NET-5TX device has five 10/100 MBit/s twisted pair ports (RJ-45 connectors) and is plugged onto the standard bar.

It is possible to connect up to five, data terminal equipments or other network segments to the TP ports using twisted pair cabling.

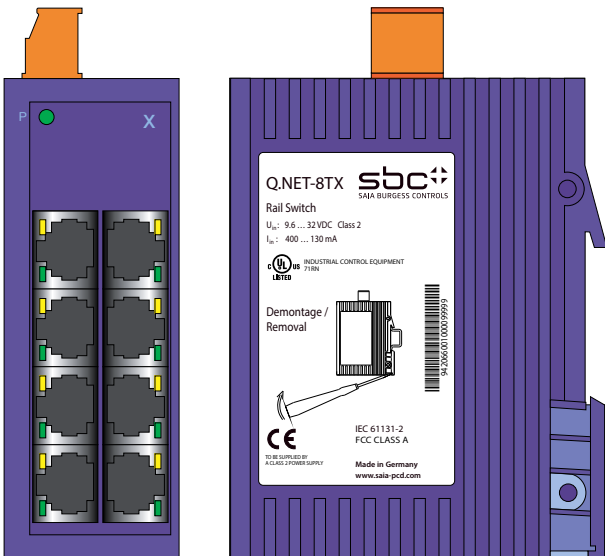

The Rail Switch / media converter Q.NET-8TX, is a switch especially designed for use in industrial environments. It supports ETHERNET 10 MBit/s and Fast ETHERNET 100 MBit/s.

The Q.NET-8TX device has eight 10/100 MBit/s twisted pair ports (RJ-45 connectors) and is plugged onto the standard bar.

It is possible to connect up to eight, data terminal equipments or other network segments to the TP ports using twisted pair cabling.

The device supports switched ETHERNET networks in accordance with IEEE standard 802.3 or 802.3u using copper technology.

The TP ports support autonegotiation, auto-polarity and autocrossing.

The performance features described here are binding only if they have been expressly guaranteed in the contract. We have checked that the contents of the technical publication agree with the hardware and software described. However, it is not possible to rule out deviations completely, so we are unable to guarantee complete agreement. However, the details in the technical publication are checked regularly. Any corrections which prove necessary are contained in subsequent editions. We are grateful for suggestions for improvement.

We reserve the right to make technical modifications.

Permission is not given for the circulation or reproduction of this document, its use or the passing on of its contents unless granted expressly. Contravention renders the perpetrator liable for compensation for damages. All rights reserved, in particular in the case of patent grant or registration of a utility or design.

Note

We would point out that the content of these operating instructions is not part of, nor is it intended to amend an earlier or existing agreement, permit or legal relationship. All obligations on Saia-Burgess Controls AG. arise from the respective purchasing agreement which also contains the full warranty conditions which have sole applicability. These contractual warranty conditions are neither extended nor restricted by comments in these operating instructions.

We would furthermore point out that for reasons of simplicity, these operating instructions cannot describe every conceivable problem associated with the use of this equipment. Should you require further information or should particular problems occur which are not treated in sufficient detail in the operating instructions, you can request the necessary information from Saia-Burgess Controls AG.

Safety Instructions

This manual contains instructions which must be observed to ensure your own personal safety and to avoid damage to devices and machinery. The instructions are highlighted with a warning triangle and are shown as follows according to the degree of endangerment:

 **Danger!**

means that death, serious injury or considerable damage to property will result if the appropriate safety measures are not taken.

 **Warning!**

means that death, serious injury or considerable damage to property can result if the appropriate safety measures are not taken.

 **Caution!**

means that light injury or damage to property can result if the appropriate safety measures are not taken.

Note: is an important piece of information about the product, how to use the product, or the relevant section of the documentation to which particular attention is to be drawn.

Certified usage

Please observe the following:

 **Warning**

The device may only be employed for the purposes described in the catalog and technical description, and only in conjunction with external devices and components recommended or approved by Saia-Burgess Controls AG. The product can only be operated correctly and safely if it is transported, stored, installed and assembled properly and correctly. Furthermore, it must be operated and serviced carefully.

Safety Guidelines Power Supply

- Switch the basic devices on only when the case is closed.

 **Warning!**

The devices may only be connected to the supply voltage shown on the type plate. The devices are designed for operation with a safety extra-low voltage. Thus, they may only be connected to the supply voltage connections with PELV circuits or alternatively SELV circuits with the voltage restrictions in accordance with IEC/EN 60950-1.

- For the case where the module is operated with external power supply: Use only a safety extra-low voltage in accordance with IEC/EN 60950-1 to power the system.

- First of all you connect the ground connection, before you establish the further connections. When you remove connections, you disconnect the ground connection last.

- Relevant for North America: The subject unit is to be supplied by a Class 2 power source complying with the requirements of the National Electrical Code, table 11(b).

- Relevant for North America: Power, input and output (I/O) wiring must be in accordance with Class I, Division 2 wiring methods [Article 501-4(b) of the National Electrical Code, NFPA 70] and in accordance with the authority having jurisdiction. Peripheral equipment must be suitable for the location it is used in. Use 60/75 °C or 75 °C copper(CU)wire only.

Safety Guidelines Shielding Ground

- Beware of possible short circuits when connecting a cable section with conductive shielding braiding.

Safety Guidelines Housing

 **Warning!**

Only technicians authorized by Saia-Burgess Controls AG. are permitted to open the housing.

Note: The Q.NET-5TX is grounded via a pin of the 3pin terminal block.

- Make sure that the electrical installation meets local or nationally applicable safety regulations.

 **Warning!**

The ventilation slits must not be covered so as to ensure free air circulation. The distance to the ventilation slots on the top and the bottom of the housing has to be a minimum of 10 cm. Never insert pointed objects (thin screwdrivers, wires, etc.) into the inside of the subrack! Failure to observe this point may result in injuries caused by electric shocks.

Note: If installed in a living area or office environment, the device must be operated exclusively in switch cabinets with fire protection characteristics according to EN 60950-1.

Note: The housing has to be mounted in upright position.

Safety Guidelines Environment



Warning!

The device may only be operated in the listed ambient temperature range at the listed relative air humidity (non-condensing).

- The installation location is to be selected so as to ensure compliance with the climatic limits listed in the Technical Data.
- To be used in an up to Pollution Degree 2 environment only (IEC 60664-1).

Staff qualification requirements

Note: Qualified personnel, as understood in this manual and in the warning signs, are persons who are familiar with the setup, assembly, startup, and operation of this product and are appropriately qualified for their job. This includes, for example, those persons who have been:

- trained or directed or authorized to switch on and off, to ground and to label power circuits and devices or systems in accordance with current safety engineering standards
- trained or directed in the care and use of appropriate safety equipment in accordance with the current standards of safety engineering
- trained in providing first aid.

General Safety Instructions

• This device is electrically operated. Adhere strictly to the safety requirements relating to voltages applied to the device as described in the operating instructions!



Warning!

Failure to observe the information given in the warnings could result in serious injury and/or major damage.

Only personnel that have received appropriate training should operate this device or work in its immediate vicinity. The personnel must be fully familiar with all of the warnings and maintenance measures in these operating instructions. Correct transport, storage, and assembly as well as careful operation and maintenance are essential in ensuring safe and reliable operation of this device.

Use only undamaged parts!

- These products are only to be used in the manner indicated in this version of the „Description and Operating Instructions“.
- Particular attention is to be paid to all warnings and items of information relating to safety.



Warning!

Any work that may have to be performed on the electrical installation should be performed by fully qualified technicians only.

Based specifications and standards:

The device fulfils the following specifications and standards:

- EN 61000-6-2:2001 -Generic standards Immunity for industrial environments
- EN 55022:1998 + A1:2000 + A2:2003 Information technology equipment - Radio disturbance characteristics
- EN 60950-1:2001 - Safety of Information Technology Equipment (ITE)
- EN 61131-2:2003 - Programmable Controllers
- FCC 47 CFR Part 15:2004-Code of Federal Regulations
- cUL 508:1998 - Underwriters Laboratories Inc. Safety for Industrial Control Equipment. Certified devices are marked with a certification identifier.

CE identification

The devices comply with the regulations of the following European directive:

89/336/EEC

Council Directive on the harmonization of the legal regulations of member states on electromagnetic compatibility (amended by Directives 91/263/EEC, 92/31/EEC and 93/68/EEC).

The EU declaration of conformity is kept available for the responsible authorities in accordance with the above-mentioned EU directives at:

Saia-Burgess Controls AG.
Bahnhofstrasse 18
3280 Murten/Schweiz

The product can be used in the residential sphere (residential sphere, business and trade sphere and small companies) and in the industrial sphere.

- Interference immunity:
EN 61000-6-2:2001

- Radio interference level:
EN 55022:1998 +
A1:2000 + A2:2003, Class A



Warning!

This is a Class A device. This equipment may cause radio interference if used in a residential area; in this case it is the operator's responsibility to take appropriate measures.

The precondition for compliance with EMC limit values is strict adherence to the construction guidelines specified in this description and operating instructions.

FCC Note:

This equipment has been tested and found to comply with the limits for a Class A digital device, pursuant to part 15 of the FCC Rules. These limits are designed to provide reasonable protection against harmful interference when the equipment is operated in a commercial environment. This equipment generates, uses, and can radiate radio frequency energy and, if not installed and used in accordance with the instruction manual, may cause harmful interference to radio communications. Operation of this equipment in a residential area is likely to cause harmful interference in which case the user will be required to correct the interference at his own expense.



Recycling Note:

After its use, this product has to be processed as electronic scrap and disposed of according to the prevailing waste disposal regulations of your community/district/country/ state.

1. Functional description

The 10/100BASE-T(X) ports of a Q.NET-5TX/-8TX represents a terminal connection for the connected LAN segment. You can connect single devices or complete network segments.

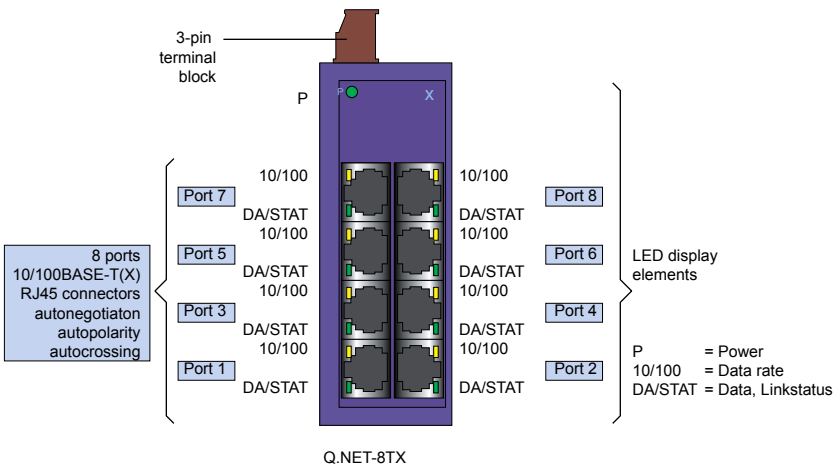
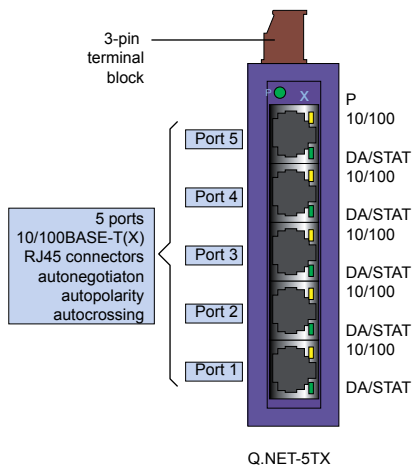

1.1 FRAME SWITCHING FUNCTIONS

Store and Forward

All data received by the Q.NET-5TX/-8TX from the system bus or at the ports are stored and checked for validity. Invalid and defective frames (> 1.522 byte or CRC error) as well as fragments (< 64 byte) are discarded. The Q.NET-5TX/-8TX forwards the valid frames.

Multi address capability

A Q.NET-5TX learns all source addresses per port. Only packets with

- unknown addresses
- addresses learnt at this port
- a multi/broadcast address

in the destination address field are sent to this port.

A Q.NET-5TX/-8TX learns up to 1,000 addresses. This becomes necessary if more than one terminal device is connected to one or more ports. In this way several independent subnetworks can be connected to a Q.NET-5TX/-8TX.

Learnt addresses

A Q.NET-5TX/-8TX monitors the age of the learned addresses. The Q.NET-5TX/-8TX deletes address entries from the address table which exceed a certain age (300 seconds)

Note: Restarting deletes the learned address entries.

Tagging (IEEE 802.1Q)

The IEEE 802.1 Q standard designates the VLAN tag to be included in a MAC data frame for the VLAN and prioritizing functions. The VLAN tag consists of 4 bytes (2 bytes tag protocol identifier TPID, 2 bytes tag control information TCI). It is inserted between the source address field and the type field. Data packets with VLAN tag are transmitted unchanged by the Q.NET-5TX/-8TX.

1.2 SPECIFIC FUNCTIONS OF THE TP/TX INTERFACE

Link control

The Q.NET-5TX monitors the connected TP line segments for short-circuit or interrupt using regular link test pulses in accordance with IEEE standard 802.3 10BASE-T/100BASE-TX.

The Q.NET-5TX/-8TX does not transmit any data to a TP segment from which it does not receive a link test pulse.

i Note:

A non-occupied interface is assessed as a line interrupt. The TP line to terminal equipment which is switched off is likewise assessed as a line interrupt as the deenergised bus coupler cannot transmit link test pulses.

Auto polarity exchange

If the receive line pair is incorrectly connected (RD+ and RD- switched) polarity is automatically reversed.

Autonegotiation

Autonegotiation is a procedure in which the switch automatically selects the operating mode of its 10/100 RJ-45 ports. When a connection is set up for the first time, the switch detects the speed (10 or 100 Mbit/s) and the transmission mode of the connected network (half duplex or full duplex).

Autocrossing

The Q.NET-5TX/-8TX detects the transmit and receive pairs (MDI, MDI-X). The Q.NET-5TX/-8TX automatically configures its port for the correct transmit and receive pins. Consequently it does not matter whether you connect the device using a cross-over or straight cable.

1.3 FURTHER FUNCTIONS AND FEATURES

Reset

The Q.NET-5TX/-8TX will be reset by the following action:

- input voltages fall below a threshold

After a reset the following action is carried through:

- initialization

1.4 DISPLAY ELEMENTS

Equipment status

These LEDs provide information about statuses which affect the function of the entire Q.NET-5TX/-8TX.

P - Power (green LED)

- lit:
 - supply voltage present

Port Status

These LEDs display port-related information.

DA/STAT - Data, Link status (green LED)

- not lit:
 - no valid link
- lit green:
 - valid link
- flashes green:
 - data traffic

10/100 - Data rate (yellow LED)

Twisted Pair Ports

- not lit:
 - 10 Mbit/s link
- lit yellow:
 - 100 Mbit/s link

1.5 INTERFACES

10/100 MBit/s connection

Q.NET-5TX Five ports (port 1 bis 5)
Q.NET-8TX Eight ports (port 1 bis 8)
(10/100 Mbit/s, 8-pin RJ-45 sockets) allow terminal equipment or up to five/eight independent network segments complying with the standards IEEE 802.3 100BASE-TX / 10BASE-T to be connected.

These ports support autonegotiation, autopolarity and autocrossing.

- Pin configuration of the RJ-45 socket:
 - 1 line pair: pin 3 and pin 6
 - 1 line pair: pin 1 and pin 2
 - remaining pins: not used.

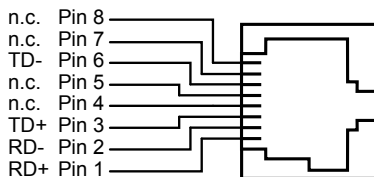

Fig. 2: Pin configuration of aTP interface

3pin terminal block

The supply voltage is connected via a 3pin terminal block.

Note: Terminal tightening torque of line binding screws: 0.5 Nm



Warning!

The Q.NET-5TX device is designed for operation with a safety extra-low voltage. Thus, it may only be connected to the supply voltage connections with PELV circuits or alternatively SELV circuits with the voltage restrictions in accordance with IEC/EN 60950-1.

- **Voltage supply:** The supply voltage is electrically isolated from the housing.

- **Ground connection:** The Q.NET-5TX/-8TX is grounded via a pin of the 3pin terminal block.

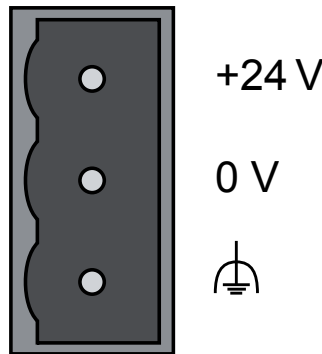

Fig. 3: Pin configuration of 3pin terminal block

2. Configuration

2.1 CONNECTING DTE AND OTHER NETWORK SEGMENTS

It is possible to connect with Q.NET-5TX/-8TX up to five data terminal equipments (DTE) or other network segments to the 10/100 Mbit/s ports using twisted pair cabling (ref. Fig. 8).

3. Assembly, startup procedure and dismantling

3.1 UNPACKING, CHECKING

- Check whether the package was delivered complete (see scope of delivery).
- Check the individual parts for transport damage.



Warning!

Use only undamaged parts!

3.2 Dimensions

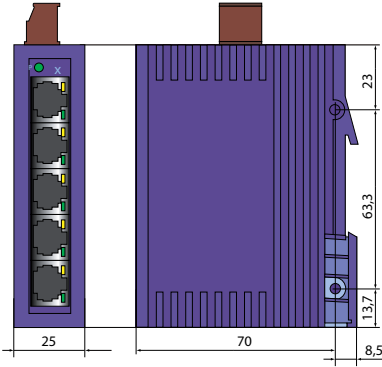

Fig. 4: Dimensions Q.NET-5TX

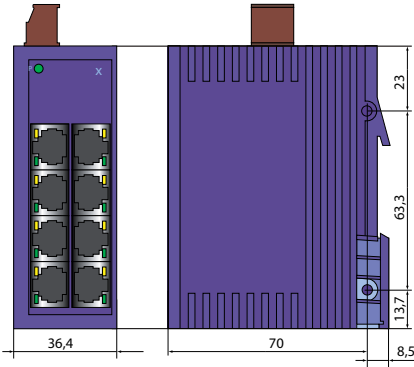

Fig. 5: Dimensions Q.NET-8TX

3.3 ASSEMBLY

The equipment is delivered in a ready-to-operate condition. The following procedure is appropriate for assembly:

- Pull the terminal block off the Q.NET-5TX/-8TX and wire up the supply voltage lines.
- Fit the Q.NET-5TX/-8TX on a 35 mm standard bar to DIN EN 50 022.
- Attach the upper snap-on slide bar of the Q.NET-5TX/-8TX to the standard bar and press it down until it locks in position.
- Fit the signal lines.

Notes:

- The Q.NET-5TX/-8TX is grounded via a pin of the terminal block.
- Do not open the housing.
- The shielding ground of the twisted pair lines which can be connected is electrically connected to the ground connection.

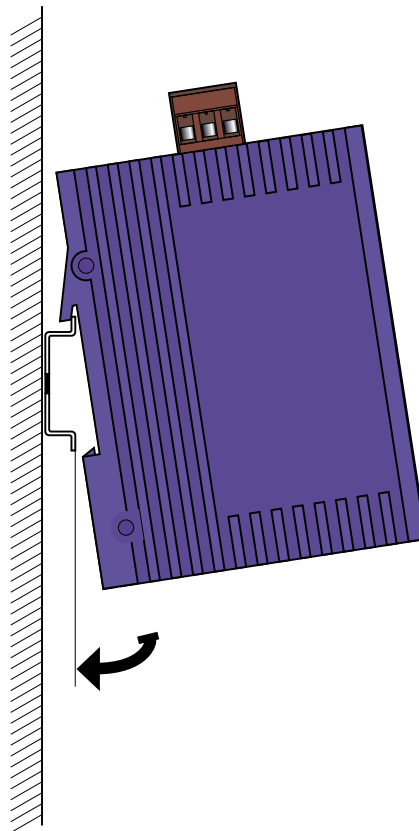

Fig. 5: Assembling

3.4 STARTUP PROCEDURE

- You start up the Q.NET-5TX/-8TX by connecting the supply voltage via the 3-pin terminal block.

3.4 DISMANTLING

- To take the Q.NET-5TX/-8TX off the ISO/DIN rail, unlock the snap-in mechanism according to Fig 7.

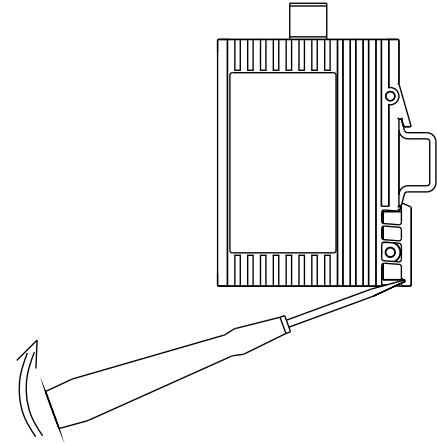

Fig. 7: Dismantling

4. Further support

In the event of technical queries, please contact directly:

Saia-Burgess Controls AG.
 Bahnhofstrasse 18
 3280 Murten / Switzerland
 T +41 26 672 72 72
 F +41 26 672 74 99
 support@saia-pcd.com
 www.saia-pcd.com
 Technical support:
 www.saia-support.com

There you will have an up-to-date overview of training courses about technology and products as well as answers to FAQs.

5. Technical data

General data		
Operating voltage		NEC Class 2 power source 9.6 VDC ... 32.0 VDC safety extra-low voltage (SELV/PELV) 5 A max.
Buffer time		min. 10 ms at 20.4 VDC
Potential difference between input voltage and housing		Potential difference to input voltage, +24 VDC: 32 VDC Potential difference to input voltage, ground: -32 VDC
Current consumption at 24 VDC		2.2 W maximum; 7.5 Btu (IT)/h
Dimensions W × H × D	Q.NET-5TX	25 mm × 114 mm × 79 mm
	Q.NET-8TX	36.4 mm × 114 mm × 79 mm
Weight Q.NET-5TX / Q.NET-8TX		113 g (0.25 lb) / 180 g (0.4 lb)
Weight Q.NET-5TX / Q.NET-8TX verpackt		230 g (0.51 lb) / 270 g (0.6 lb)
Ambient temperature		Surrounding air, 0 °C to + 60 °C (32 °F to 140 °F)
Storage temperature		Surrounding air, -40 °C to + 70 °C (-40 °F to 158 °F)
Humidity		up to 95% (non condensing)
Atmospheric pressure		up to 2000 m (795 hPa, higher altitudes on demand)
Pollution Degree		2
Protection type		IP 30
Interference proof		
Discharge of static electricity		
Contact discharge		EN 61000-4-2 Test level 3
Air discharge		EN 61000-4-2 Test level 3
Electromagnetic fields		EN 61000-4-3 Test level 3
Fast transients		EN 61000-4-4 Test level 3
Surge voltage symmetrical		EN 61000-4-5 Test level 2
Surge voltage asymmetrical		EN 61000-4-5 Test level 3
Cable-based RF faults		EN 61000-4-6 Test level 3
EMC emitted immunity		
EN 55022		Class A
FCC 47 CFR Part 15		Class A
Stability		
Vibration		IEC 60068-2-6 Test FC, testing level in line with EN 61131-2:2003
Shock		IEC 60068-2-27 Test Ea, testing level in line with EN 61131-2:2003
Certifications		
cUL 508 / CSA 22.2 No.142		E175531
Network size		
TP port 10BASE-T/100BASE-TX Length of a twisted pair segment		100 m (328 ft) max.
Interfaces	Q.NET-5TX	5 TP ports, RJ-45 sockets, 10/100 Mbits/s
	Q.NET-8TX	8 TP ports, RJ-45 sockets, 10/100 Mbits/s
Displays		
Equipment status		1 × green LED; P - power, supply voltage present
Port status		5 × green LEDs; DA/STAT - data, link status 5 × yellow LEDs; 10/100 - data rate
Equipment status		1 × green LED; P - power, supply voltage present
Port status		8 × green LEDs; DA/STAT - data, link status 8 × yellow LEDs; 10/100 - data rate
Scope of delivery		
Rail Switch Q.NET-5TX incl. terminal block for supply voltage description and operating instructions		
Order number	5 TP-Ports	Q.NET-5TX
	8 TP-Ports	Q.NET-8TX

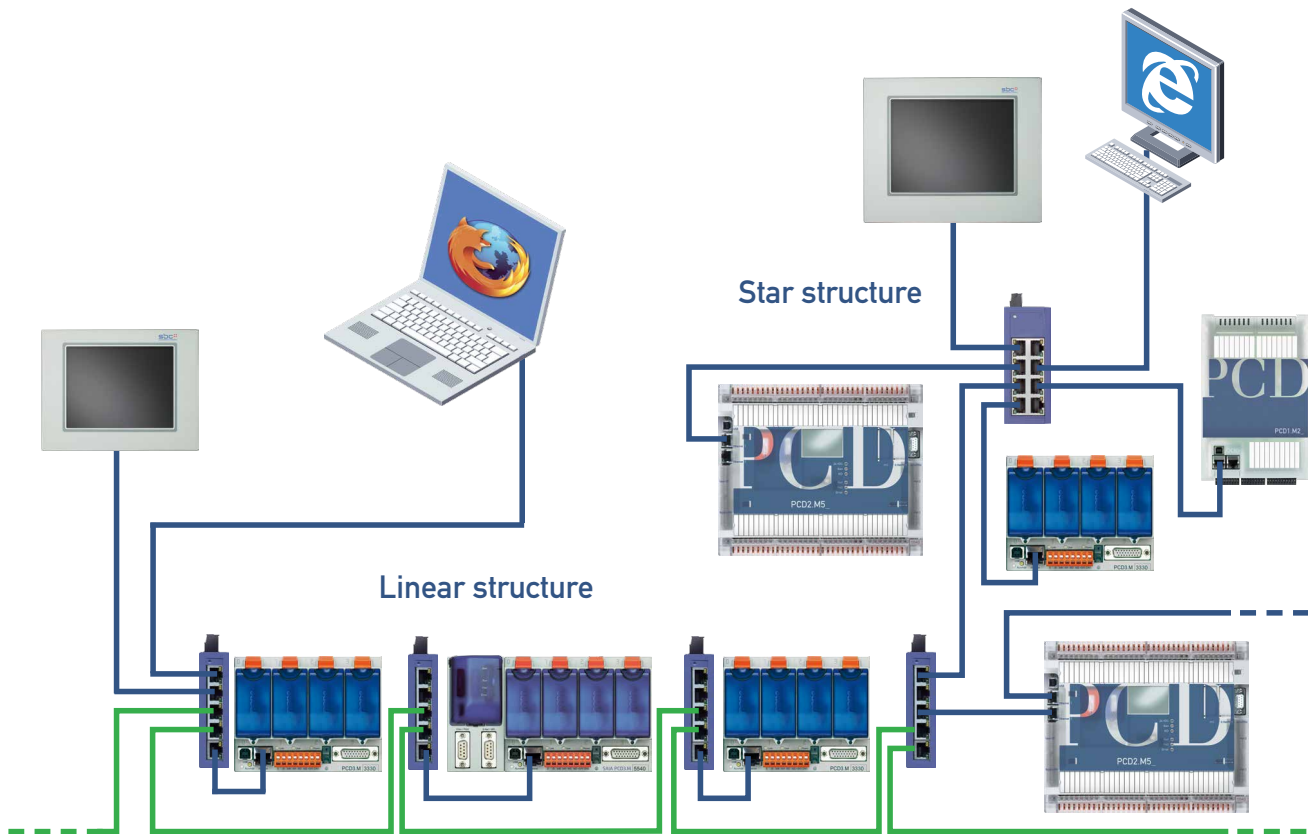

Abb. 8 Configuration

Saia-Burgess Controls AG

Bahnhofstrasse 18 | 3280 Murten, Switzerland
T +41 26 672 72 72 | F +41 26 672 74 99
www.saia-pcd.com

pcdsupport@saia-pcd.com | www.sbc-support.com