



## PCD7.D51x0TL series (Windows CE)

<b>0</b>	<b>Contents</b>	
0.1	Document History .....	0-2
0.2	Brands and trademarks .....	0-2
<b>1</b>	<b>Introduction</b>	
<b>2</b>	<b>Product description</b>	
2.1	User side .....	2-2
2.2	Slot side .....	2-2
2.3	Interfaces .....	2-3
2.3.1	Compact Flash slot .....	2-3
2.3.2	VGA/COM1/PS/2 interface .....	2-3
2.3.3	Ethernet, USB .....	2-4
2.4	Back .....	2-4
<b>3</b>	<b>Commissioning</b>	
3.1	Power supply .....	3-1
3.2	Earthing concept .....	3-2
3.3	Flush mounting .....	3-2
3.4	Switch-on .....	3-2
<b>4</b>	<b>Basic settings and first steps</b>	
<b>5</b>	<b>Technical data</b>	
5.1	Physical dimensions .....	5-1
5.1.1	PCD7.D5100TLxxx exterior/flush mounting dimensions .....	5-2
5.1.2	PCD7.D5100TLxxx unit dimensions .....	5-3
5.1.3	PCD7.D5120TLxxx exterior/flush mounting dimensions .....	5-4
5.1.4	PCD7.D5120TLxxx dimensions: .....	5-5
5.1.5	PCD7.D5150TLxxx exterior/flush mounting dimensions .....	5-6
5.1.6	PCD7.D5150TLxxx unit dimensions: .....	5-7
5.2	Electrical data .....	5-8
5.3	Environmental conditions .....	5-8
<b>6</b>	<b>Maintenance and support</b>	
6.1	Battery changing .....	6-1
6.2	Replacing background lighting .....	6-1
6.3	Cleaning .....	6-2
6.4	Usage instructions for touch screens .....	6-2
<b>A</b>	<b>Appendix</b>	
A.1	Icons .....	A-1
A.2	Contact .....	A-2

## 0.1 Document History

Date	Version	Changes	Remarks
pEN01	2009-07-06		Initial version
EN01	2009-08-07		Released version
EN02	2014-03-20		updated

## 0.2 Brands and trademarks

Saia PCD® and Saia PG5® are registered trademarks of Saia-Burgess Controls AG.

Microsoft, Windows 2000, Windows XP, Windows CE and the Windows logo are either registered trademarks or trademarks of Microsoft Corporation in the USA and/or other countries.

Technical modifications are based on the current state-of-the-art technology.

Saia-Burgess Controls AG, 2009 © All rights reserved.

Published in Switzerland

# 1 Introduction

The PCD7.D5xxx series is suitable for visualising process data of low to medium complexity. The process architecture used (AMD Geode LX800) gives the units a lower power leakage and higher operating temperature range than earlier x86 systems, combined with lower equipment costs.

The devices have been developed for use with the Windows CE open operating system. The 2 USB ports can be used to connect external keyboards, mice, USB sticks or certain models of printer. The integrated Ethernet interface allows the units to be simply incorporated into existing computer networks or used as web panels.

In conjunction with the (optional) Saia PG5® Web Editor visualisation software, the devices can be used to visualise SPS data from Saia PCD® Classic and PCD xx7 series controls.

The series comprises the PCD7.D5100TL010, PCD7.D5120TL010 and PCD7.D5150TL010 models.



## User side

Colour TFT display with resistive touch  
(PCD7.D5100TL010, PCD7.D5120TL010 and PCD7.D5150TL010)



## Slot side

## 2 Product description

The PCD7.D51xxTL series comprises compact, mechanically robust, fanless industrial PCs. This embedded PC system is supplied both as a box and in combination with high-contrast industrial colour TFT displays. Screen sizes of 10.4", 12" and 15" are available. The analogue resistive touchscreen is the basis for man-machine communication. The combination of a standardised CPU unit and different front units enables it to be perfectly matched to your requirements. Its small dimensions are a further advantage.

The use of special procesors dispnses with the need for sensitive fan systems.

Hard disks are replaced with Compact Flash cards, so the breakdown rate is very low, in spite of the often harsh industrial environment.

The PCD7.D51xxTL series web panels are available with the Windows® CE operating system, allowing you to visualise and control your equipment in a robust and reliable way.

<i>CPU Unit</i>	<i>CPU:</i>	<i>On Board AMD Geode™ LX 800/700 (533 MHz) CPU</i>
	System memory:	200-pin DDR SDRAM 256 MB
	Chipset:	AMD LX series + CS5536
	I/O chipset:	IT8712/FKX + IT8888G
	BIOS:	Award 512 KB FLASH ROM
	Battery:	CR2032 lithium battery
	SSD:	External type II Compact Flash™
	Display chipset:	AMD LX series + TI SN75LVDS83
Interfaces	Serial:	1× RS-232
	Ethernet:	2× Realtek RTL8139DL, 10/100Base-TX RJ45 connector
	USB:	2× USB2.0
	Memory card (ext.):	Type II Compact Flash
	Mouse and keyboard:	Via mini DIN PS/2 Y cable

## 2.1 User side

Colour resistive touch TFT display - 10.4", 12" or 15"



2

## 2.2 Slot side

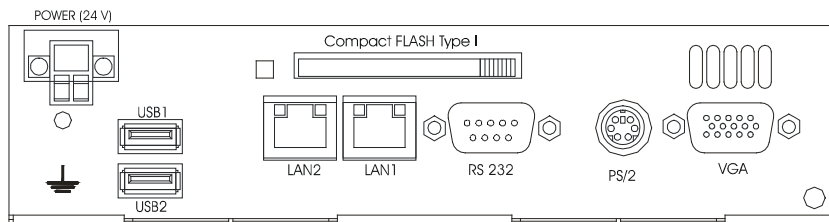

**2.3 Interfaces**

**2.3.1 Compact Flash slot**

The PCD7.D51xxTL series web panels units are fitted with a CFA standard (type 1) Compact Flash slot as standard.

Position of Compact Flash slot



Captive screw

**Note:**

Only Compact Flash cards from SANDISK may be used in conjunction with the web panel.

The Compact Flash card should only be changed with the device switched off.

**2.3.2 VGA/COM1/PS/2 interface**

- ❶ VGA port
- ❷ COM 1
- ❸ PS/2 mouse/ keyboard

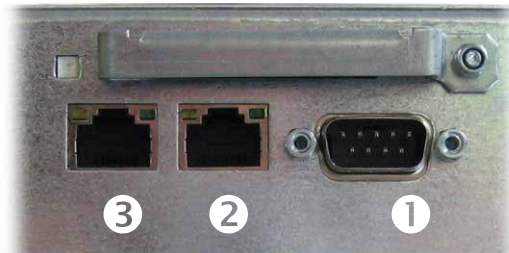

PS2 adapter cable for mouse and keyboard

On all standard PCD7.D51xxTL web panels, the debug port is supplied as a serial interface.

This interface can be configured as a debug port to support program development.

**Note:**

COM 1 is only available when it has been software-enabled.

The serial port is configured to the PC XT/AT standard.

**Note:**

The PS/2 mouse and keyboard may only be plugged or removed with the unit switched off.

Otherwise these input devices will not be recognised by the operating system.

### 2.3.3 Ethernet, USB

- ❶ Ethernet 1 (RJ45)
- ❷ Ethernet 2 (RJ45)
- ❸ USB 1/2

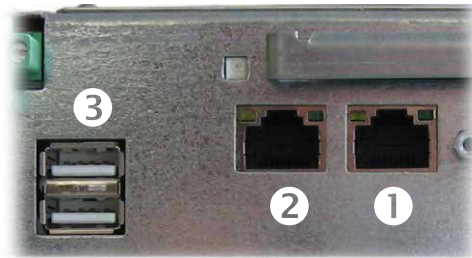

### 2.4 Back





### 3 Commissioning

#### 3.1 Power supply



The PCD7.D51xxTL devices must only be run on functional extra-low voltage with secure insulation in accordance with EN60950. The control transformer must comply with EN60742.

3

The supply voltage must be checked against the type plate.

When wiring the power supply and the connector, the details on the type plate must be observed.

Before commissioning the system, all cable connections should be checked.

The 0V power supply has a low-resistance connection to the casing (earth).

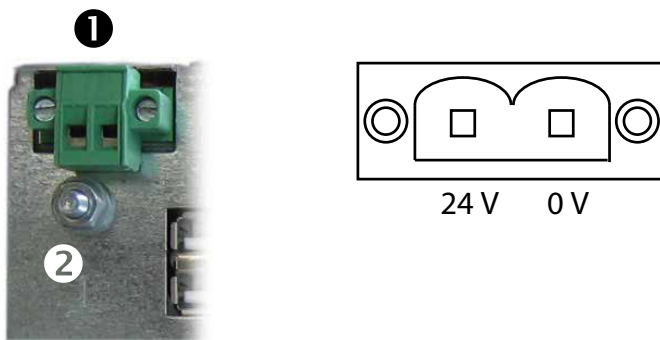

- ❶ 24V power supply
- ❷ Earth screw

The power supply is connected via a two-pole plug connector (Phoenix MST BT 2.5/2-STF-5.08).

#### Supply layout

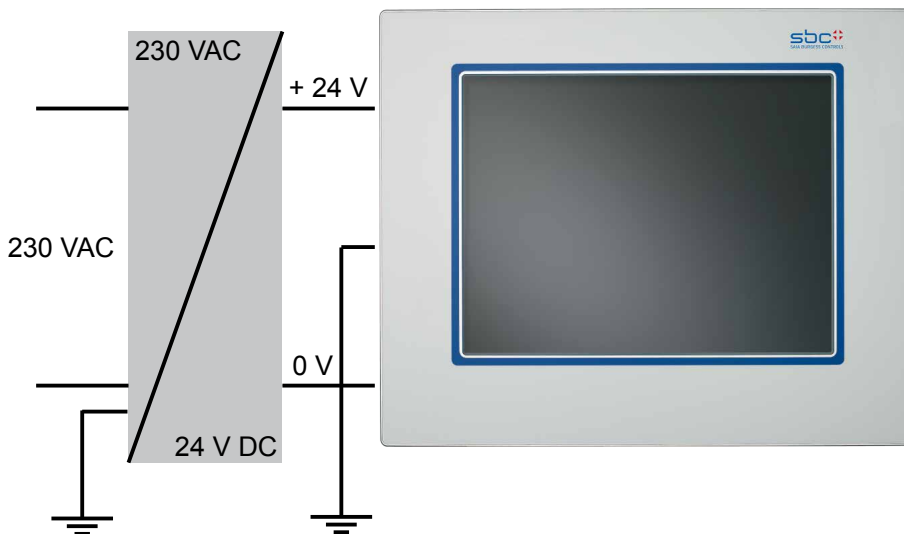

### 3.2 Earthing concept

To ensure that electrical faults are dealt with safely, the following points should be observed:

- Connect device and switching cabinet by the shortest route to a central earthing point.
- Ensure lowest impedance possible in connection between device and switching cabinet.
- All data cables connected to the device should use shielded lines.
- The shields should be earthed at both ends. There must be a low-resistance connection between the linked systems. High equalising currents across the shield resulting from potential differences must be avoided.
- Earth connection to use green/yellow cable with min. 4 mm<sup>2</sup> cross-section.

### 3.3 Flush mounting

The device should be installed in an RF shielded housing or a metal switching cabinet.

Adequate ventilation must be provided. To ensure that the heat generated in the device can be dissipated, a 100 mm space must be kept clear around the unit.

The device is secured with eight hexagonal nuts.



The unit must be disconnected from the power supply for installation and de-installation.

Only the assembly components supplied should be used to mount the unit in the housing.

IP65 protection to the front can only be guaranteed if the seal is correctly positioned on the front plate.

When installed, a 100 mm space must be kept clear to allow air to circulate around the unit.

The type and number of assembly components is dependent on the device (see Technical Details).



The use of Compact Flash cards from different manufacturers may cause faults.

Where an internal and an external Compact Flash card are used, they must be from the same manufacturer (same type and same size).



Failure to observe the above instructions could cause damage to the device.

### 3.4 Switch-on

Start-up: The PCD7.D51xxTL units boot up and load the operating system independently.

## 4 Basic settings and first steps

This section is still being written and will be published with the next release.

## 5 Technical data

### 5.1 Physical dimensions

Clearance      To ensure that the heat generated in the device can be dissipated, a 50 mm space must be kept clear around the unit.

**5.1.1 PCD7.D5100TLxxx exterior/flush mounting dimensions**

Front plate:	Width 318 mm Height 244 mm
Aperture size:	Width 303 mm Height 228 mm
Depth:	77 mm
Weight:	approx. 2.8 kg
Type of fixing:	6 aluminium or plastic brackets with M5×30 grub screws; DIN 914, with head and hexagonal recess, zinc-plated.

5

Front plate, view to front of device

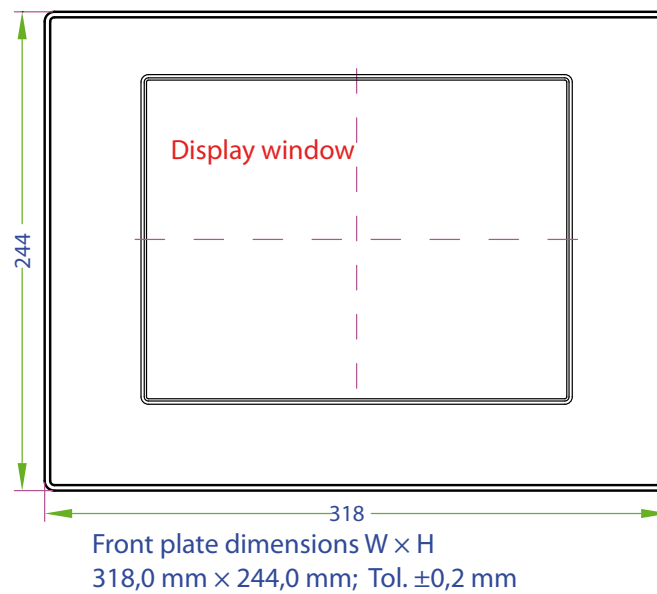

Opening in front panel for flush mounting

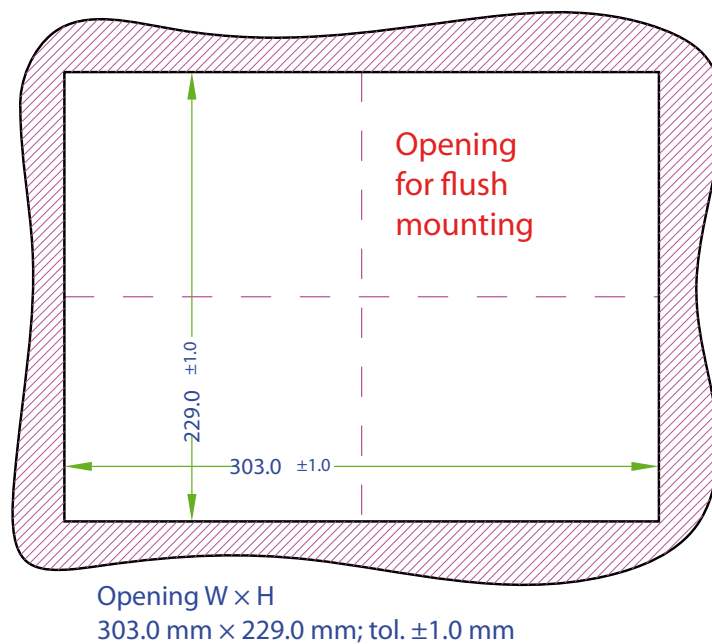

**5.1.2 PCD7.D5100TLxxx unit dimensions**

5

View to underside of device

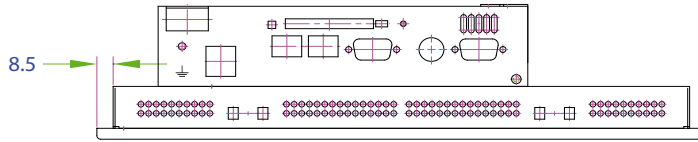

Side view

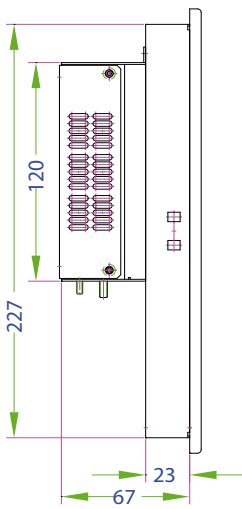

View to rear of device

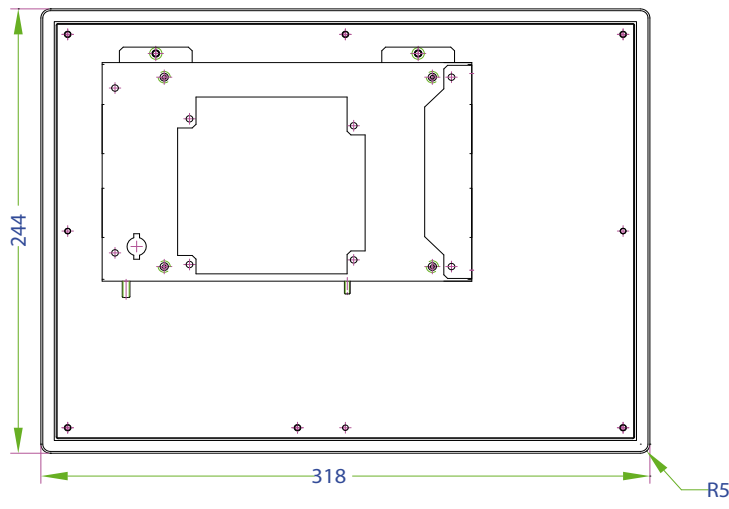

Side view

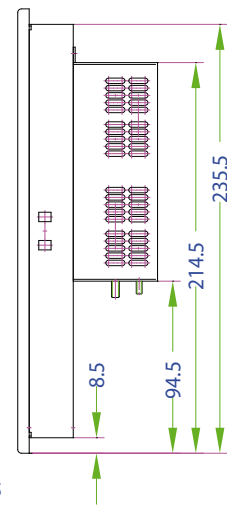

View to top of device

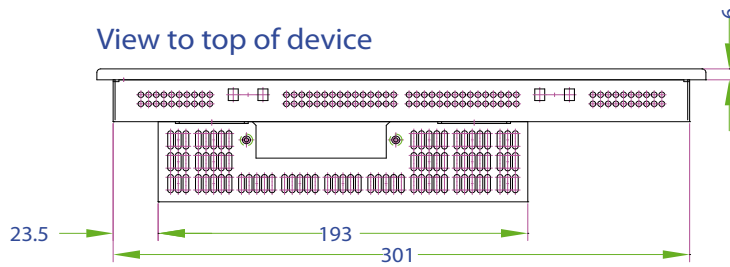

**5.1.3 PCD7.D5120TLxxx exterior/flush mounting dimensions**

- Front plate:           Width 364 mm  
                          Height 296 mm
- Aperture size:       Width 345 mm  
                          Height 277 mm
- Depth:                77 mm
- Weight:               approx. 2.8 kg
- Type of fixing:       8 M4 threaded bolts recessed into the front plate.
- Surround thickness max. 5.0 mm

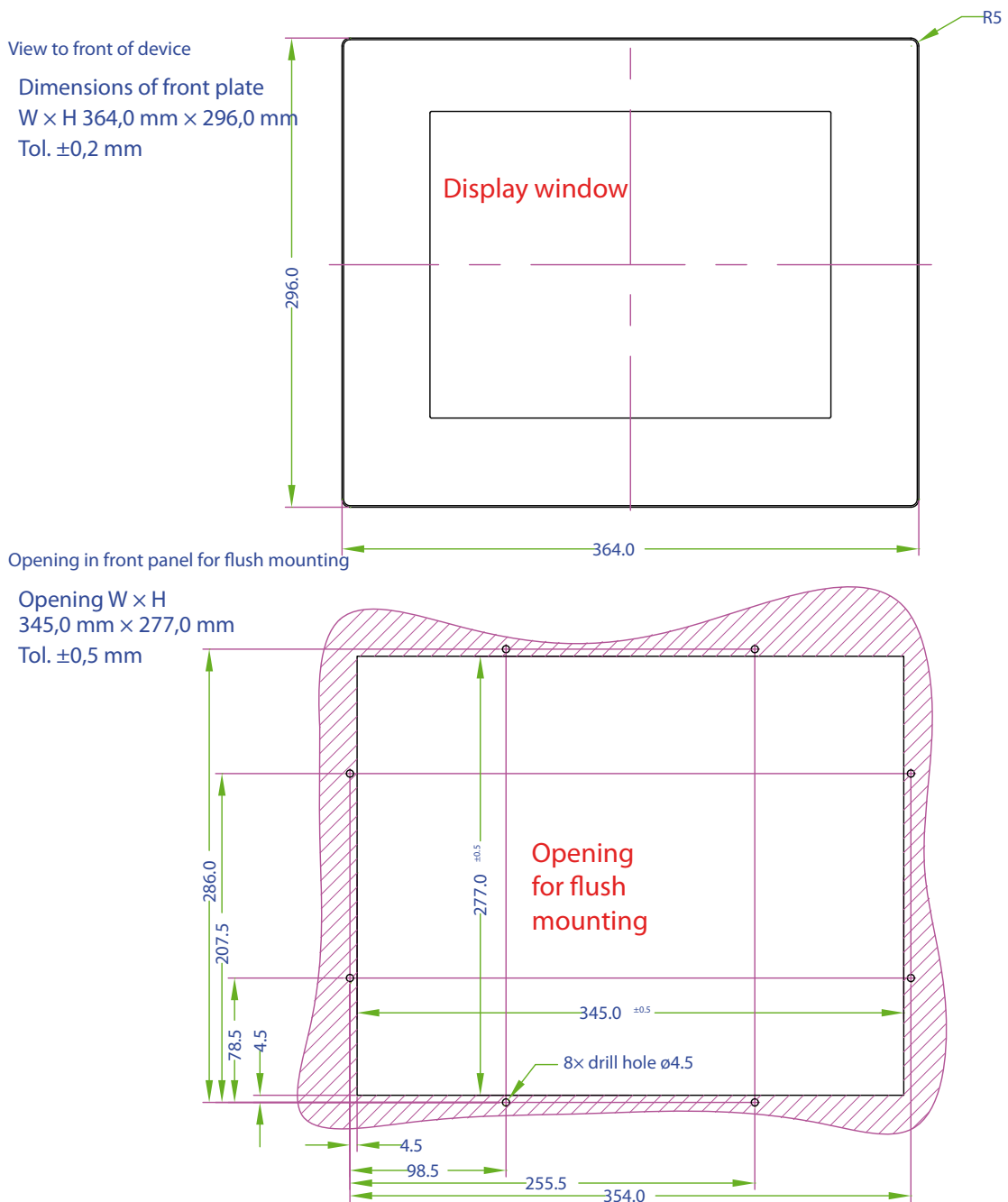

**5.1.4 PCD7.D5120TLxxx dimensions:**

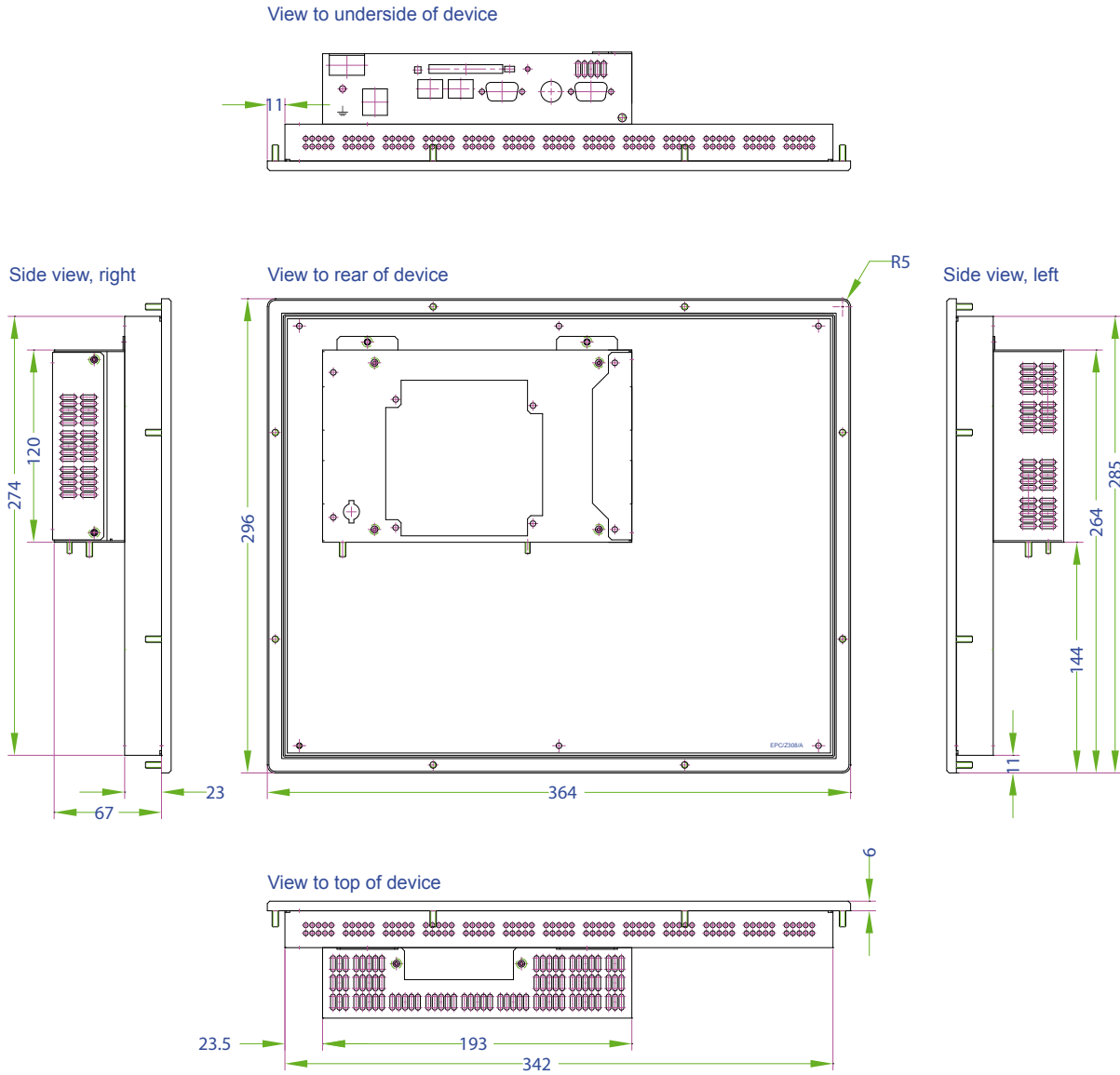



**5.1.5 PCD7.D5150TLxxx exterior/flush mounting dimensions**

- Front plate:           Width 452 mm  
                          Height 334 mm
- Aperture size:       Width 429 mm  
                          Height 334 mm
- Depth:                86 mm
- Weight:               approx. ... kg
- Type of fixing:       6 aluminium or plastic brackets with M5×30 grub screws;  
                          DIN 914, with head and hexagonal recess, zinc-plated.

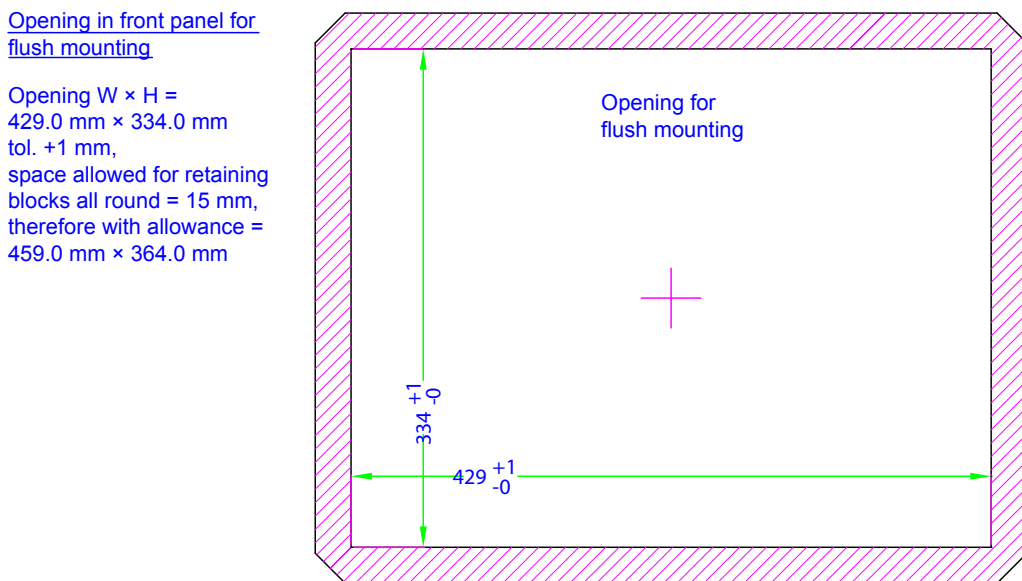
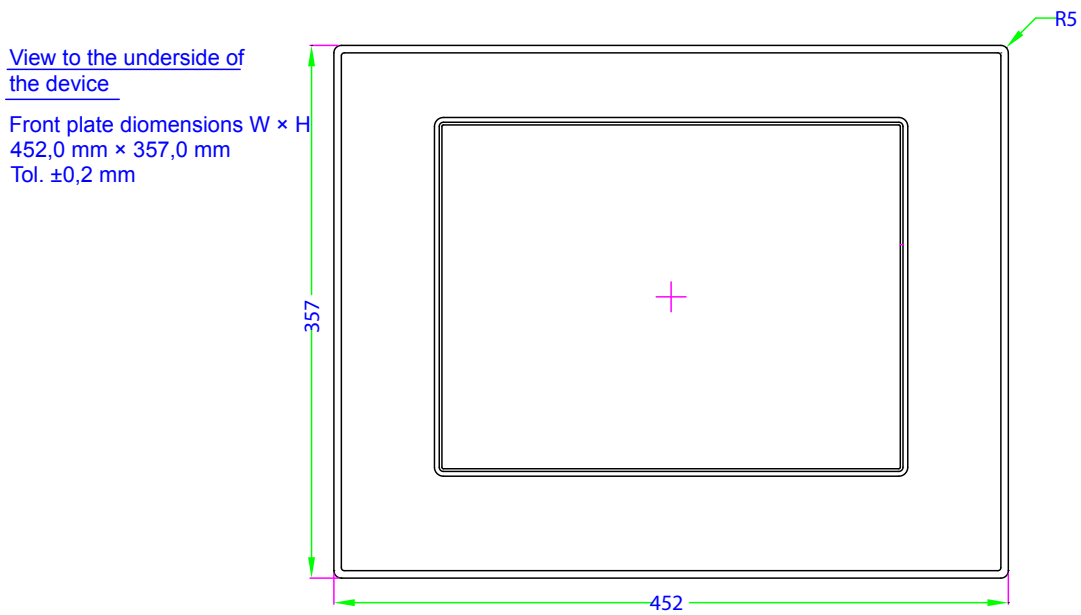

**5.1.6 PCD7.D5150TLxxx unit dimensions:**

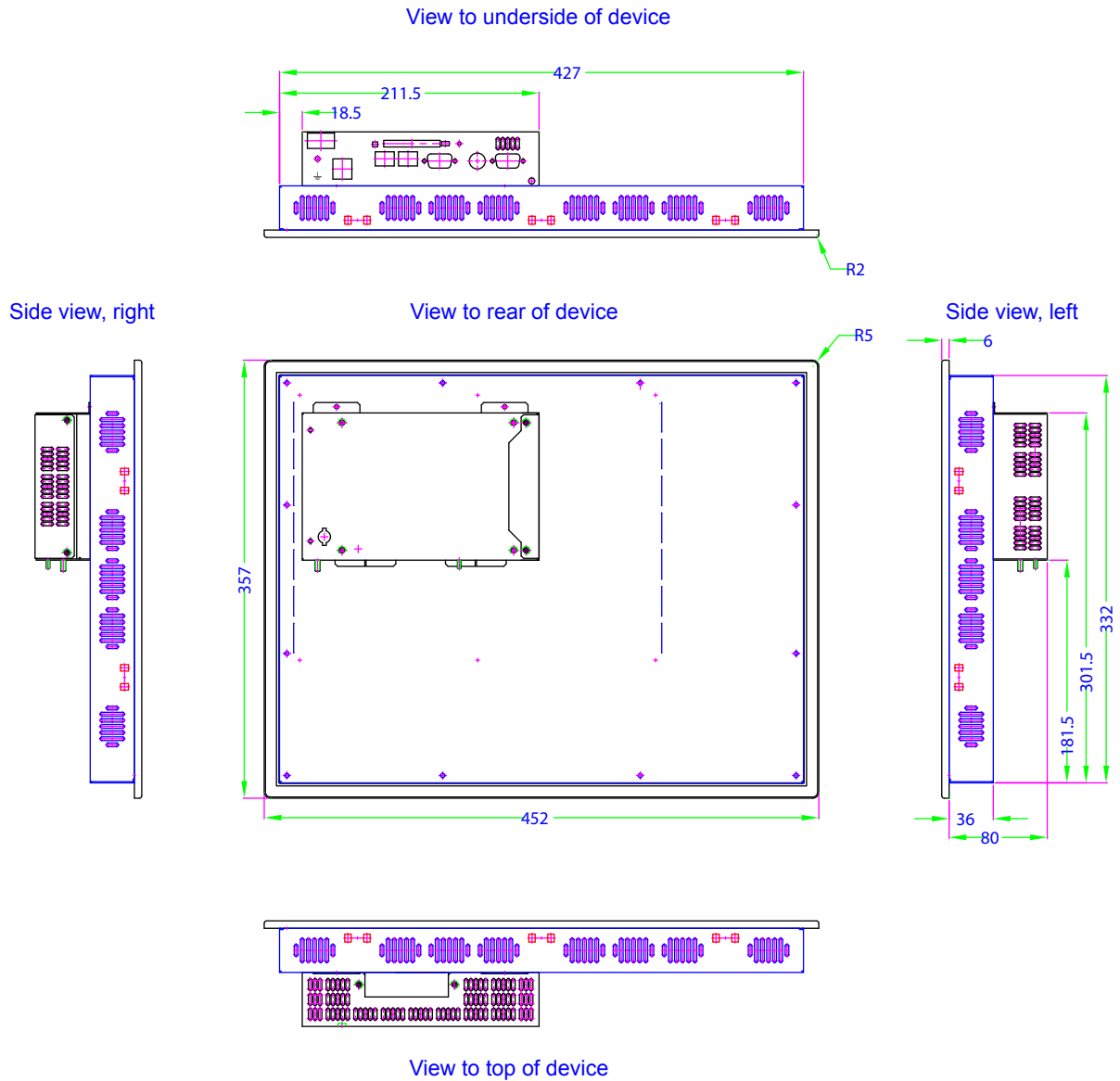

## 5.2 Electrical data

Model	PCD7.D5100TLxxx	PCD7.D5120TLxxx	PCD7.D5150TLxxx
<b>Power supply</b>			
Operating voltage	24 V ± 20%, reverse voltage protected		
Current consumption	approx. 0.90 A	approx. 1.10 A	approx. 1.5 A
Fuse	2.5 A slow-blow		
Jumper time	1 ms at 19.2 V (Ub-20%)		
<b>Display unit</b>			
Display size (inches)	10.4	12	15
Max. brightness (cd/m <sup>2</sup> )	350	300	300
Resolution (pixels)	800 × 600	800 × 600	1024 × 768
Touchscreen	resistive		
Processor type	Onboard AMD Geode™ LX 800/700(533 MHz) CPU		
Working memory	200-pin DDR SDRAM 256 MB		
Chipset	AMD LX series + CS5536		
I/O chipset	IT8712/FKX + IT8888G		
BIOS	Award 512 KB FLASH ROM		
Battery	CR2032 lithium battery		
SSD	Internal type II Compact Flash™		
Display chipset	AMD LX series + TI SN75LVDS83		
<b>Interfaces</b>			
Serial	1 RS-232		
Ethernet	2× Realtek RTL8139DL, 10/100Base-TX RJ45 connector		
USB	2× USB2.0		
Memory card (external)	Type II Compact Flash		
Mouse and keyboard	Via mini DIN PS/2 Y cable		

## 5.3 Environmental conditions

<b>Ambient temperature</b>		
Operation	0 ... 50° C	
Storage	-20 ... 60° C	
<b>Humidity acc. to DIN EN60068-2-3</b>		
Operation	10 ... 75%, non-condensing	
Storage	10 ... 95%, non-condensing	
<b>Vibration in operation</b> acc. to DIN EN60068-2-6	Sinus	2 g, 10 ... Hz
	Shock	15 g, 11 ms
	Prolonged shock	10 g, 16 ms
	Free fall	from 1 m (in packaging), 1× per axis
<b>Protection type</b> acc. to DIN EN60529	Front	IP 65
	Back	IP 20
<b>EMV/CE</b>	Resistance to interference	EN 61000-6-2
	Noise emission	EN 61000-6-4

## 6 Maintenance and support

### 6.1 Battery changing

The devices are fitted with an integrated lithium battery for data buffering.



Battery type:	CR2032, 3V / 230mAh coin cells
Manufacturer:	e.g. Varta, type 6032
Buffer current:	2 $\mu$ A typ. / 15 $\mu$ A max.
Battery voltage monitoring:	yes (functionality dependent on software)
Battery life (typ.) :	5 years

6

Battery life is basically dependent on the prevailing environmental conditions (operating temperature, switch-on/switch-off time, humidity). The lifetime given here assumes that the device is switched on regularly (several times a week / at least 1500 hours a year).

The battery should only be changed by trained specialists. ESD protective measures should be observed.

Before changing the battery, the device should be disconnected from the power supply.

The PCD7.D5xxx units do not have to be taken out of the switching cabinet. It is sufficient to loosen the two screws on the back plate (hexagonal recess, size 2.0) and open the back plate downwards. Hold the back plate roughly horizontal with one hand.

Push the battery contacts back with a plastic object (e.g. touch stylus) until the battery pops out of the holder. Remove the battery. Insert new battery into the battery holder and clip in place. The positive pole of the battery must point upwards / be visible.



When the battery is changed, the real-time clock data will be lost.

Do not short-circuit the battery contacts. Risk of explosion. Battery should only be replaced with the same type from the same manufacturer.

Lithium batteries are hazardous waste. Used batteries should be disposed of in accordance with national guidelines.

### 6.2 Replacing background lighting

It is advisable to allow Saia-Burgess Controls AG to replace the tubes for the background lighting. The projected lifetime of the tubes can be found in the Technical Data.

The tubes for the background lighting contain traces of mercury and are hazardous waste. They must be disposed of in accordance with national guidelines.

### 6.3 Cleaning

Only mild cleaning agents should be used to clean the front of the unit (e.g. neutral soap solution or dilute washing-up liquid). Always use a clean, soft cloth for cleaning.



Do not use any cleaning agents that contain granules (e.g. scouring powder or cleansing milk). These may affect the readability of the display or damage the touch screen.





Do not use acetone or benzene.

### 6.4 Usage instructions for touch screens

The touch screen should only be operated with the hand or a specially designed touch stylus. Using sharp metal objects (e.g. screwdrivers) may damage the touch screen.

## A Appendix

### A.1 Icons

	<p>In manuals, this symbol refers the reader to further information in this manual or other manuals or technical information documents. As a rule there is no direct link to such documents.</p>
	<p>This symbol warns the reader of the risk to components from electrostatic discharges caused by touch. <b>Recommendation:</b> Before coming into contact with electrical components, you should at least touch the Minus of the system (cabinet of PGU connector). It is better to use a grounding wrist strap with its cable permanently attached to the Minus of the system.</p>
	<p>This sign accompanies instructions that must always be followed.</p>
	<p>Explanations beside this sign are valid only for the Saia PCD® Classic series.</p>
	<p>Explanations beside this sign are valid only for the Saia PCD® xx7 series.</p>

**A.2 Contact****Saia-Burgess Controls AG**

Bahnhofstrasse 18  
3280 Murten  
Switzerland

Phone ..... +41 26 672 72 72

Fax..... +41 26 672 74 99

Email support: ..... [support@saia-pcd.com](mailto:support@saia-pcd.com)

Supportsite: ..... [www.sbc-support.com](http://www.sbc-support.com)

SBC site: ..... [www.saia-pcd.com](http://www.saia-pcd.com)

International Representatives &

SBC Sales Companies: ..... [www.saia-pcd.com/contact](http://www.saia-pcd.com/contact)

**Postal address for returns from customers of the Swiss Sales office****Saia-Burgess Controls AG**

Service Après-Vente  
Bahnhofstrasse 18  
3280 Murten  
Switzerland

A