

Serie PCD7.D450WTPx and PCD7.D570WTPx Wide Screen Micro-Browser Panels

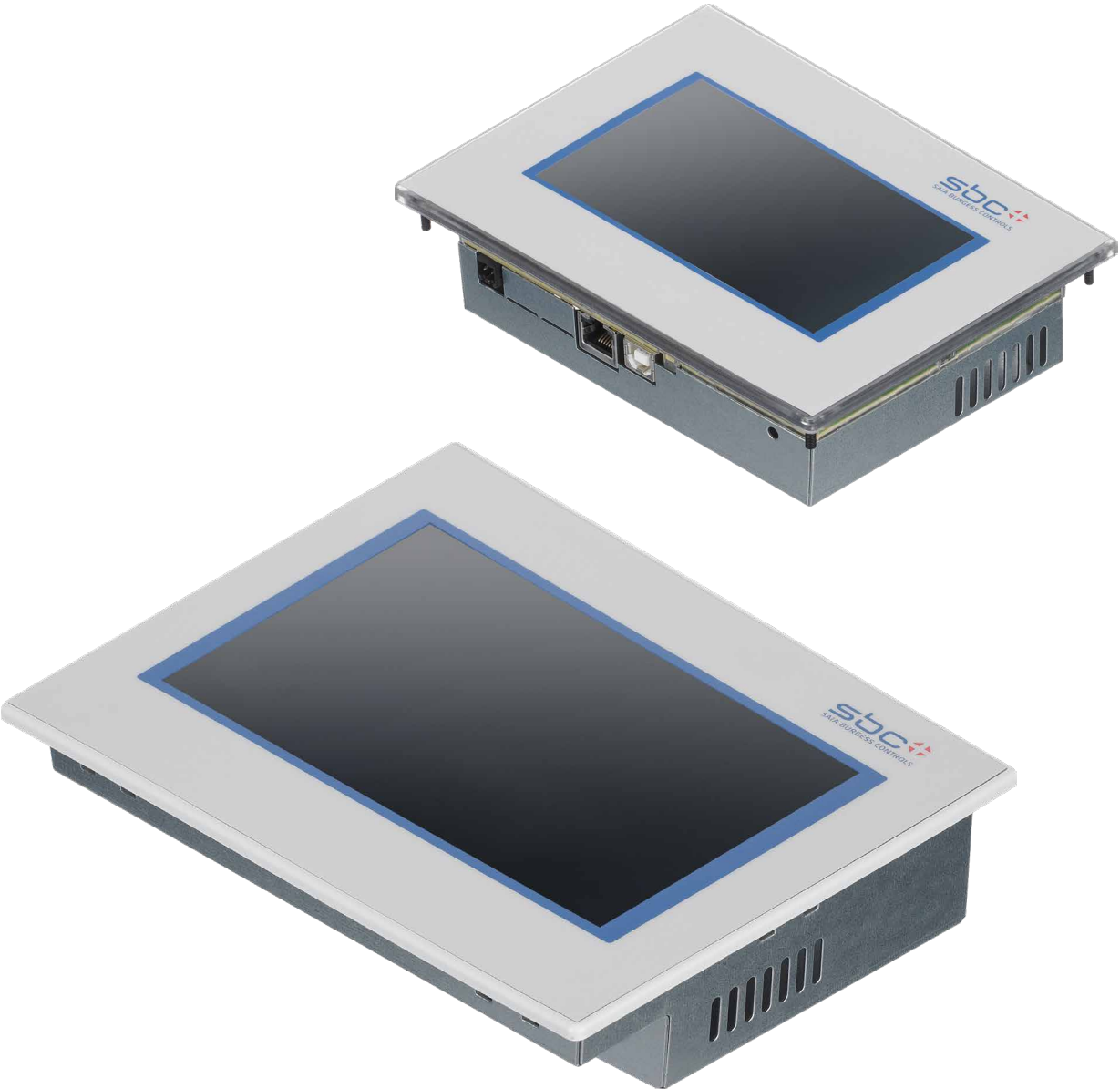

0	Content	
0.1	Document versions	0-4
0.3	Brands and trademarks	0-4
1	Quickstart	
1.1	Introduction	1-1
1.2	Definition of the connectors	1-2
1.3	Voltage supply of the panel	1-3
1.4	Dimensions and cut-out [in mm]	1-4
1.4.1	5" panel	1-4
1.4.2	7" panel	1-4
1.5	Installation of the panels	1-5
1.5.1	Installation in control cabinet	1-5
1.6	Operation and handling of the touchscreen	1-6
1.7	Setting up communications for displaying a website	1-7
1.7.1	HTTP Direct over ethernet RJ-45 connector	1-7
1.7.2	USB port as service port	1-8
1.7.3	Accessing the web editor on the Micro Browser Panel PCD7.D4xx	1-8
2	Technical data for the two panel types	
2.1	Technical data of the WVGA MicroBrowser panel	2-1
3	Operating the setup menu of the WVGA MB panel	
3.1	Open the Setup menu	3-1
3.2	Customising the start screen	3-2
3.3	Changing the password	3-2
3.4	Saving and exiting	3-3
4	Structure and description of the Setup menu	
4.1	Network	4-2
4.1.1	DCHP On	4-2
4.1.2	TCP/IP address	4-2
4.1.3	Subnet Mask	4-2
4.1.4	Default Gateway	4-2
4.1.5	Primary DNS Server	4-2
4.1.6	Secondary DNS Server	4-2
4.2	Web Connection	4-3
4.2.1	Connection	4-3
4.2.2	Edit connection	4-3
4.2.2.1	Connection name	4-3
4.2.2.2	Start page	4-3
4.2.2.3	Remote Host IP	4-3
4.2.2.4	Remote port	4-3
4.2.2.5	Remote password	4-3
4.2.3	Default password	4-3

4.2.4	Search	4-4
4.2.4.1	Range Start	4-4
4.2.4.2	Range Size	4-4
4.2.4.3	TCP Ports	4-4
4.2.4.4	Result List	4-4
4.2.4.5	Search	4-4
4.2.4.6	Clear	4-4
4.2.5	Connection List	4-5
4.3	System	4-6
4.3.1	Info	4-6
4.3.2	Production data	4-6
4.3.3	Settings	4-7
4.3.4	Special Settings	4-8
4.3.5	Log	4-9
4.3.6	Firmware download	4-9
4.3.7	Restart	4-9
4.4	Display	4-10
4.4.1	Brightness	4-10
4.4.2	Backlight [min]	4-10
4.4.3	Rotation	4-10
4.4.4	Calibrate Touchscreen	4-10
4.5	Keyboard	4-11
4.5.1	SIP (Virtual Keyboard)	4-11
4.5.2	Name of the first keyboard	4-11
4.5.3	Width of the Focus (in Pixels)	4-11
4.6	Password	4-12
4.7	Language	4-12
5	Local files / local server	
5.1	Connecting via FTP access	5-1
5.2	INTFLASH/WEBPAGES	5-2
6	Updating and special settings	
6.1	Firmware update	6-1
6.1.1	Additional information on downloading FW	6-1
6.1.2	Secure Firmware Download via USB	6-1
6.2	Reset / Resetting the device to factory settings	6-2
6.3	Backlight	6-2
6.4	Typefaces supported by MB panel PCD7.D4xx	6-3
6.5	Special Unicode fonts	6-5
6.5.1	General information	6-5
6.5.2	Multi-languages: Example	6-7
6.5.3	Analysing incorrect fonts, font sizes or format templates	6-9
6.5.4	Web Editor	6-9
6.6	Internal special functions	6-10
6.6.1	Container variable for WVGA MB panel	6-10
6.6.2	uBT_BackLight Containerdiagramm	6-15
6.6.3	Additional uBTerminal container for "Save logs to File" function	6-15
6.7	List of message box messages	6-16

7	Handling: precautionary measures	
7.1	Glass touchscreen	7-1
7.2	Information on the LCDs of the MB panel display	7-1
7.3	Care	7-1
8	General recommendations for the Web Editor 5	
8.1	In the "Project configurations"	8-1
8.2	In the Web Editor project (general information)	8-1
8.3	Definition of an object in the Web Editor	8-2
8.4	Handling	8-2
8.5	Some rules regarding gif images	8-2
8.5.1	Decompression in the video cache at startup using the Gif list	8-3
8.5.2	Decompression of Gif files in the video cache at startup using a dummy start screen	8-4
8.5.3	Decompression of Gif files: analysis/calculation	8-4
8.6	Expanded error messages for the WVGA panel	8-5
8.7	Extended alarm macros	8-5
8.8	Trend macros for MB panels with "save logs to files"	8-5
A	Appendix	
A.1	Icons	A-1
A.2	Safety information	A-2
A.3	Waste of Electrical and Electronic Equipment (WEEE) disposal	A-3
A.4	Contact	A-4

0

0.1 Document versions

Version	Published	Redactor	Remarks
ENG01	2013-06-21	ErDa	First version of manual
ENG02	2013-07-31	HaMa	Small changes
ENG03	2015-05-18	HaMa	New translation from German
ENG04	2016-01-22	HaMa	Changes for new fixation set
ENG05	2018-07-20	HaMa	Removed «uBT_Buzz..» from the table «uBT»
ENG06	2020-02-24 2020-03-06	HaMa HaMa	New dimensions after "Value Engineering" Last page - Partner Channel
ENG07	2020-08-19	HaMa	Removed the Buzzer

0.3 Brands and trademarks

Saia PCD® and Saia PG5®
are registered trademarks of Saia-Burgess Controls AG.

Technical modifications are based on the current state-of-the-art technology.

Saia-Burgess Controls AG, 2020. © All rights reserved.

1 Quickstart

1.1 Introduction

1

This manual describes the technical aspects of the PCD7.D4xxWTPx Wide Screen MB Panel. The objective of the “Quick Start” chapter is the quick installation of the PCD7.D4xxxT5F components. You will find information on:

- Definition of the connectors
- Power supply and consumption
- Dimensions
- Possible communications modes

Other chapters contain additional details regarding:

- Hardware
- Software (Setup menu step-by-step and configuration)
- Usage, firmware update, etc.
- Maintenance

Supplementary manuals:

- PG5 2.0 User guide | 26-732
- File System and FTP Server | 26-855
- Ethernet TCP/IP | 26-766
- Smart RIO PCD3.T665 | 26-892
- Serial interface modules PCD7.F1xxx | 27-664

Definition of the connectors

1.2 Definition of the connectors

1

PCD7.D450WTPx

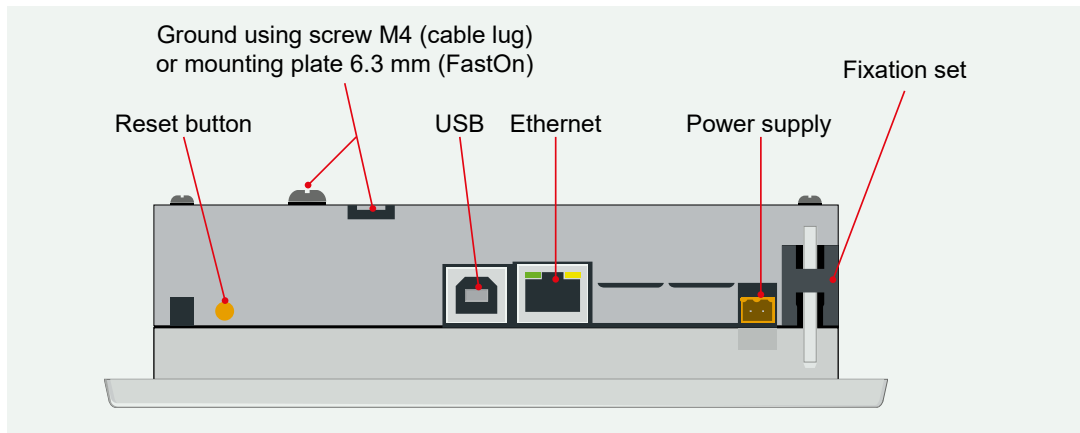

PCD7.D470WTPx

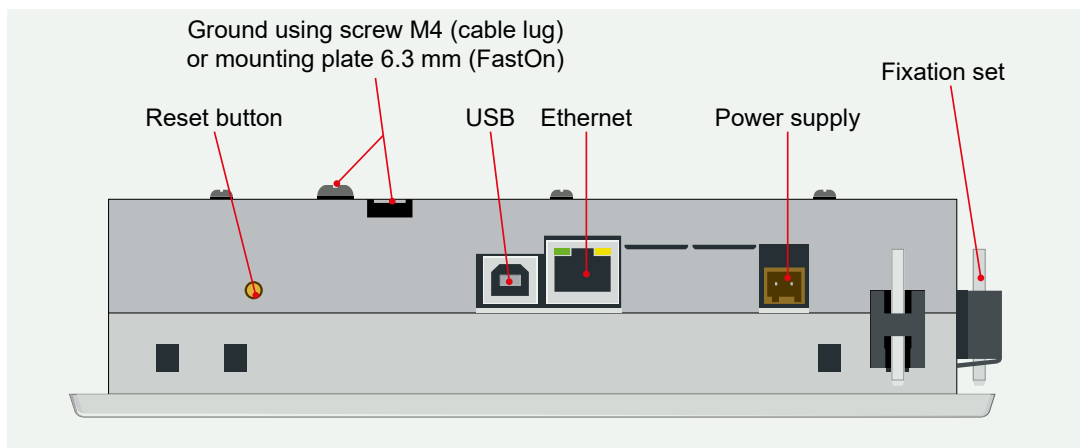

Protective earth must be connected

Power supply	Ground/Earth (-) / 24V (+)	Connector, 2-pole
Communications	1× Ethernet	1× RJ 45 with LED display
	USB	Standard USB slave
Reset button	Pushbutton	

1.3 Voltage supply of the panel

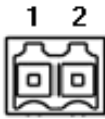

Pin	Signal
1	24V (+)
2	Earth (-)

1

Power supply:

→ 24 VDC +30% / -20%

or

→ 19 VAC ±15% current supply with full-wave rectifier

	Current consumption	Power output without backlight
PCD7.D450WTPF PCD7.D450WTPZ11 PCD7.D450WTPZxx	Max 350 mA	8 W
PCD7.D470DTPF PCD7.D470DTPZ11 PCD7.D470DTPFZxx	Max 350 mA	8 W

Current supply with jack plug for cable of max. 1.5 mm².

Dimensions and cut-out [in mm]

1.4 Dimensions and cut-out [in mm]

1

1.4.1 5" panel

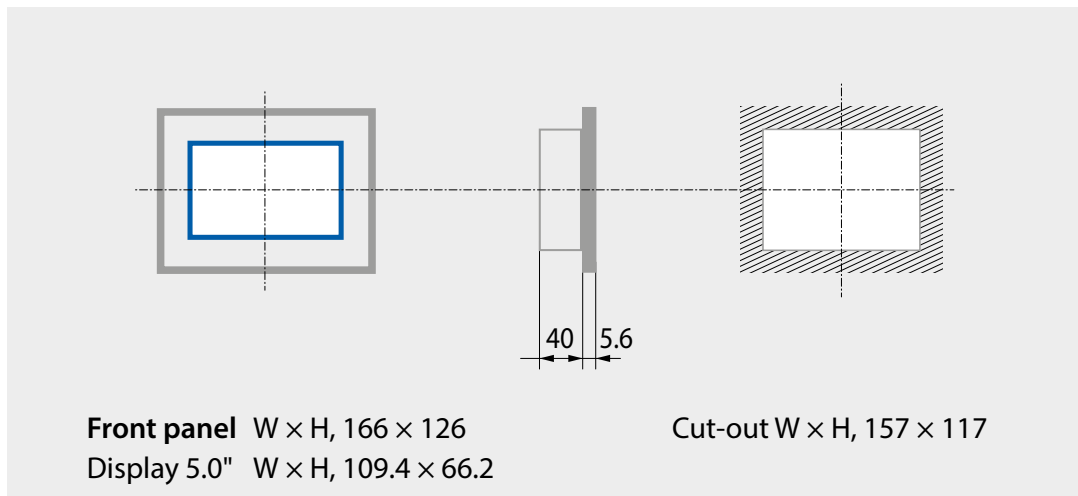

1.4.2 7" panel

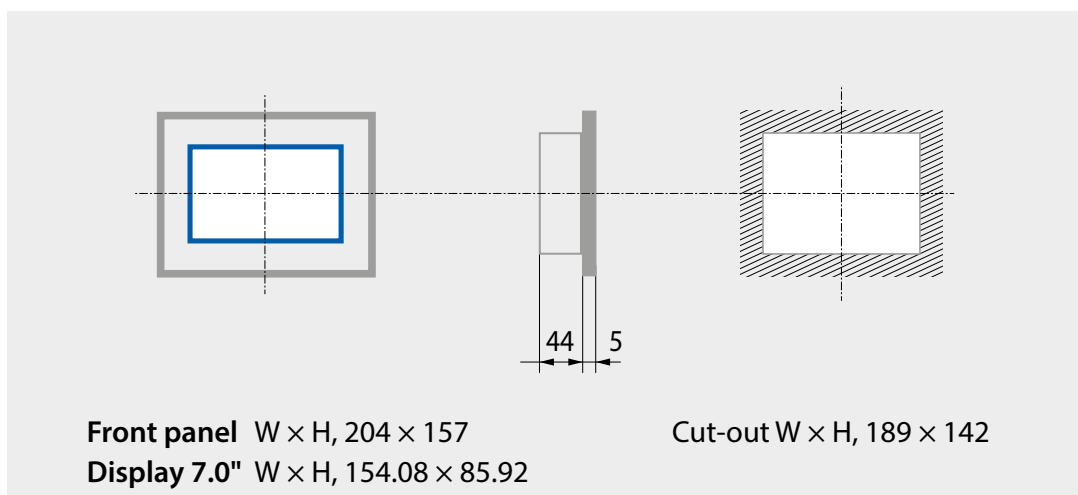

1.5 Installation of the panels

1.5.1 Installation in control cabinet

1

- The mounting position is horizontal. Place the unit in the installation cut-out.
- Make sure that the ventilation slots (at the top of the unit and on both sides) are not covered to allow air to circulate.
- Mount the 4 (or 6 for 7") attachment parts. (2 on the device and 2 under the device and 2 on the sides for 7"). See the photo below.

Attachment parts of the PCD7.D450WTPx

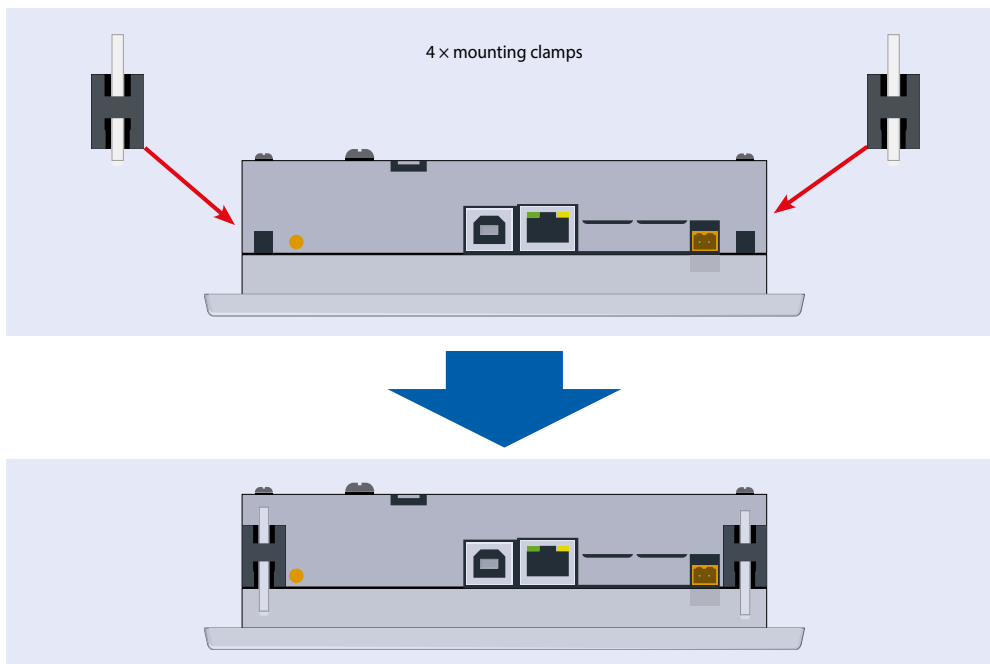

Attachment parts of the PCD7.D470WTPx

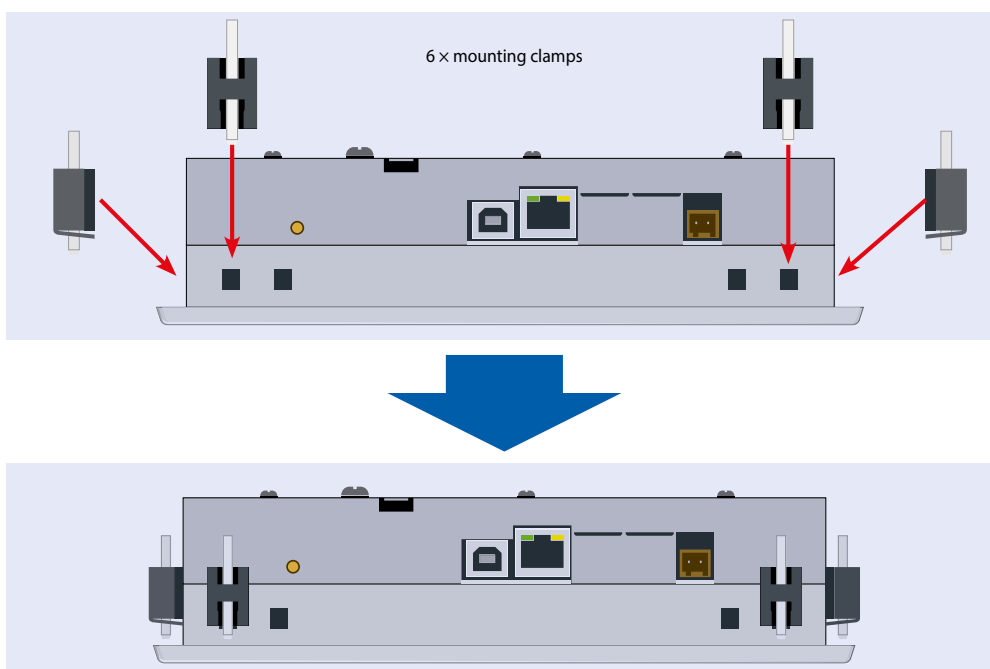

Operation and handling of the touchscreen

1

**Note:**

- The attachment parts can be mounted more easily if another user is holding the panel at the front.
- A 2.5 mm Allen key is required for the screws.
- Turn the screws in the attachment parts until they lock onto the micro browser and are not obstructed by the plate.
- Fasten the attachment bracket on the panel and tighten the screws until they touch the plate.
- The required torque to seal the gasket is 20 cNm. Do not exceed 30 cNm to avoid breaking of the clamp.

How to ensure spray water protection according to IP65:

→ The device must be mounted on a flat surface or wall. Tighten the bolts until the front plate of the PCD7.D4xx is just touching the mounting surface/wall.

1.6 Operation and handling of the touchscreen

To operate the touchscreen, use only your finger, the stylus or a soft finger stylus. Do not use sharp tools (e.g., sharp metallic objects, paperclips or a screwdriver, etc.).

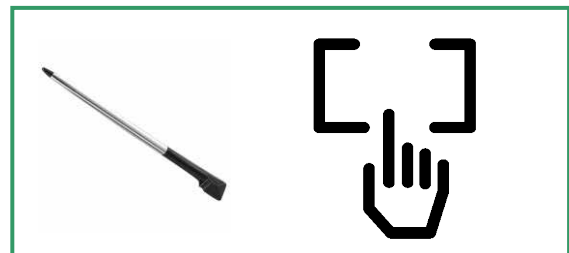
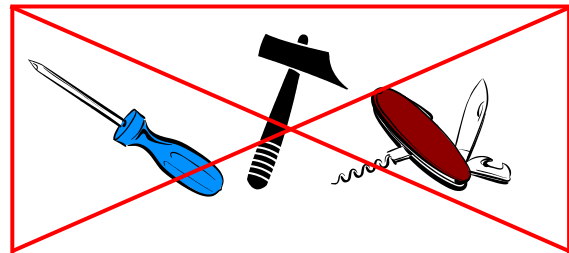

1.7 Setting up communications for displaying a website

1.7.1 HTTP Direct over ethernet RJ-45 connector

1

The fastest communication connection is the Ethernet port via RJ 45 if the HTTP direct proto-col is selected. The speed is either 10 Mbit/s or 100 Mbit/s with an Auto-Negotiation protocol via the connected device.

Connection to external devices

The HTTP connection can be established between our PCD7.D4xx and any Saia PCD control-ler if there is an Ethernet connection to the automation server.

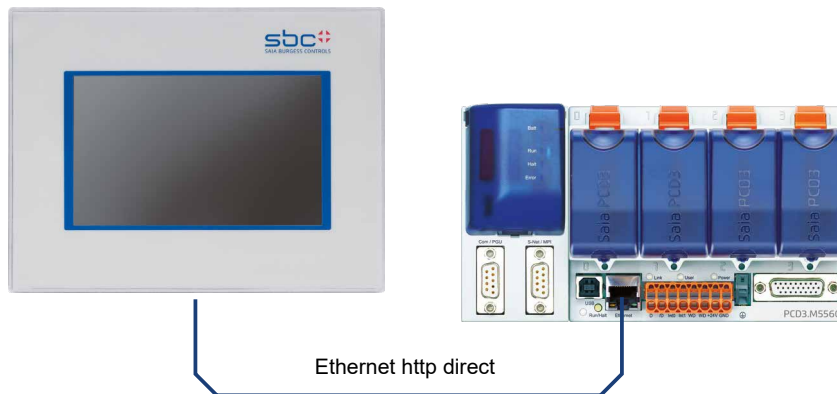

Quick test of the WVGA panel

- A web application must first be loaded into the Saia PCD that was created with the Web Editor (see 26-838_Manual_Web-Editor). Ask the SBC Support team for some examples. They will also soon be available on our website.
- With a **CAT5 cable**, you can connect the display PCD7.D4xx to the Saia PCD. The display supports auto-crossing so that a crossover cable is no longer required.
- Defining the **HW settings of the Saia PCD** with the PG5: The S-Bus support must be selected together with the TCP/IP channel in which a valid IP address must be entered.

Setup settings of the WVGA panel:

Configure the WVGA panel by opening the **setup menu** (see chapter 4):

- First make sure that they are in the same **subnet of the network** as the PCD. An exam-ple: If the Saia PCD IP address is 192.168.12.92, enter an IP address such as 192.168.12.90 at your terminal (in the network menu) as the subnet mask is normally 255.255.255.0.
- In the configuration menu, enter the **address of the start page** that corresponds to the IP address of the Saia PCD and also the name of the HTML start page.

Now the MB panel should be connected to the Saia PCD and the selected start page should be displayed on the monitor. Now you can navigate through your web-sites!

Setting up communications for displaying a website

1.7.2 USB port as service port

1

This port is generally used as a service port with the WVGA standard MB panels. It is mainly used to load new firmware into the device.

The USB port complies with the USB 1.1 specification. Highest speed: 12 Mbit/s.

1.7.3 Accessing the web editor on the Micro Browser Panel PCD7.D4xx

Detailed documentation can be downloaded from our website. See manual 26-838 Manual Web-Editor. To access the programming of the MB panel, you must note some special features:

- When creating a new project and receive no help from the assistant, you must configure the project as follows:
 - Use of the virtual keyboard with WVGA MB panels, see "4.5 Keyboard" on page 4-11
 - If you want to use the file Background.teq or foreground.teq, you should first create these files. The reason for this is... These files are first positioned on each page be-fore any objects or texts and fields appear
 - Once the project is ready for download, enter the relevant HTML file name and create a build project. Now execute a web server build in the Saia PG5 project manager so that all files access the PCD. If you only want to access the PCD with the MB panel PCD7.D4xx and not a PC browser, you can reduce the data quantity by deleting the .jar files as they are already available on the panel.

2 Technical data for the two panel types

2.1 Technical data of the WVGA MicroBrowser panel

HMI - Line	Base	Base
Type	PCD7.D450WTPF, PCD7.D450WTPZ11	PCD7.D470WTPF, PCD7.D470WTPZ11
Display		
Display size	5" TFT	7" TFT
Resolution (pixels)	WVGA 800 × 480	WVGA 800 × 480
Colours	65,536	65,536
Adjustable contrast	Yes	
Background lighting	LED (dimnable in 20 stages)	
Touch Screen	Resistive 4-wire	
CPU		
Processor	Coldfire CF5373L / 240 MHz	
Memory for local file system	128 MB	
Real-time clock (RTC)	Yes with Super-Cap	
Interfaces		
Ethernet	1× Ethernet Interface RJ 45 / http direct	
USB 12M	1× Client	
Serial	---	
Operating system	Saia PCD® COSinus	
Browser	Saia PCD® Micro Browser	
Server	FTP server	
Software tools		
Graphic editor	Web Editor 8 and 5	
Use of PG5 resources	Yes	
Technical data		
Power supply	18...32 VDC	
Current draw	350 mA	400 mA
Housing protection type (front)	IP65	
Operating temperature	0 ... 50 °C	-20 ... 70 °C
Storage temperature	-20 ... 70 °C (non-condensing)	-25 ... 70 °C (non-condensing)
Dimensions (W×H×D) [mm]	166 × 127 × 45.6	204 × 157 × 49
Cut-out (W×H) [mm]	157 × 117	189 × 142
Display size (W×H) [mm]	109.4 × 66.2	
Display size (W×H) [mm] up to HW: <F		152 × 91.44
Display size (W×H) [mm] starting with HW: ≥F		154.08 × 85.92

2

3 Operating the setup menu of the WVGA MB panel

This chapter describes the menu structure of the WVGA Micro Browser Panel

Micro Browser WVGA Panel

- PCD7.D450WTPF (5.0" WVGA)
- PCD7.D450WTPZ11 (5.0" WVGA)
- PCD7.D470WTPF (7.0" WVGA)
- PCD7.D470WTPZ11 (7.0" WVGA)

3

3.1 Open the Setup menu

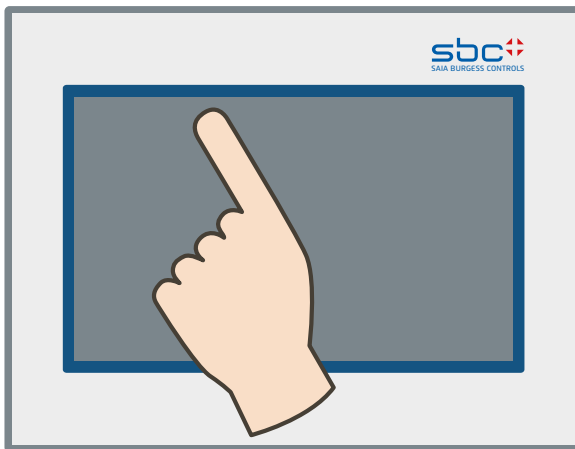

Call up setup menu:

- by pressing and holding any area for 4 seconds at any time (buttons excluded)
- by pressing on the icon depicted while booting up (see section “3.2 Customising the start screen” on page 3-2)
- the SETUP menu also includes an ONLINE function help (press the Help icon)

3.2 Customising the start screen

The title screen is displayed for a few seconds, immediately after the panel is switched on with ON. The greeting and welcome screen can be defined under → System → Start screen (see “4.3.3 Settings” on page 4-7).

3

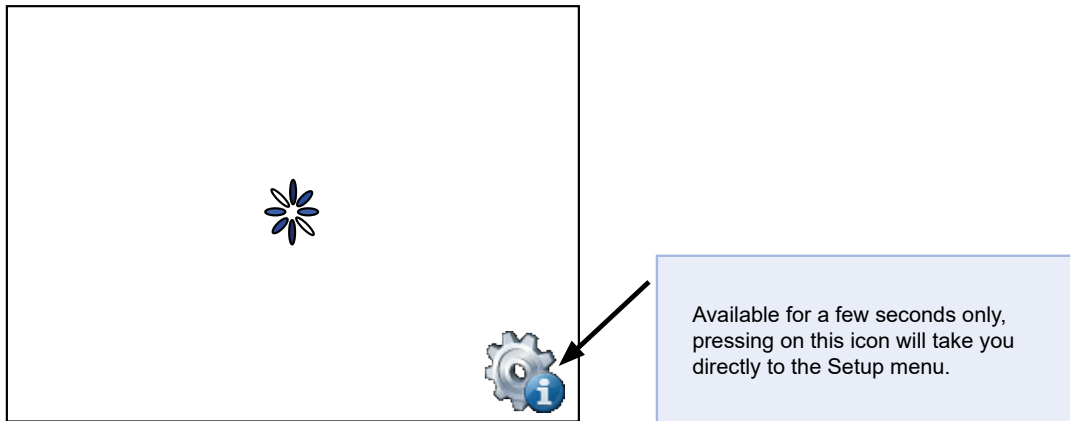

= Animated icon for “Please wait, data is being loaded”

User-defined → System → Start screen: “4.3.3 Settings” on page 4-7.

3.3 Changing the password

MB panels of the PCD7.D4xxx series are supplied without a password on the Setup menu.

However if accessing the setup menu was restricted with a password, the correct password must be entered and confirmed with OK.

→ For information on entering passwords, see “4.6 Password” on page 4-12.

3.4 Saving and exiting

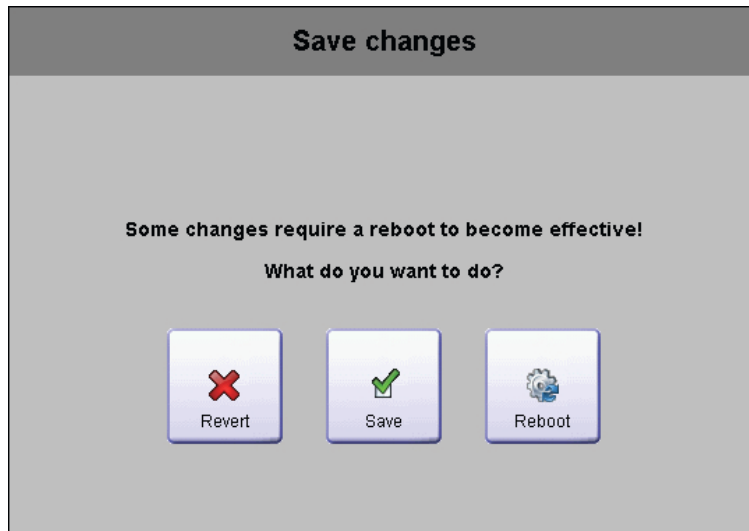

3

If you have changed one or more parameters, you must confirm if you want to save the changes, to save & reboot, or to reset the new parameters without saving.



4 Structure and description of the Setup menu

The Setup screen is the first screen which is displayed when the Setup menu is accessed.

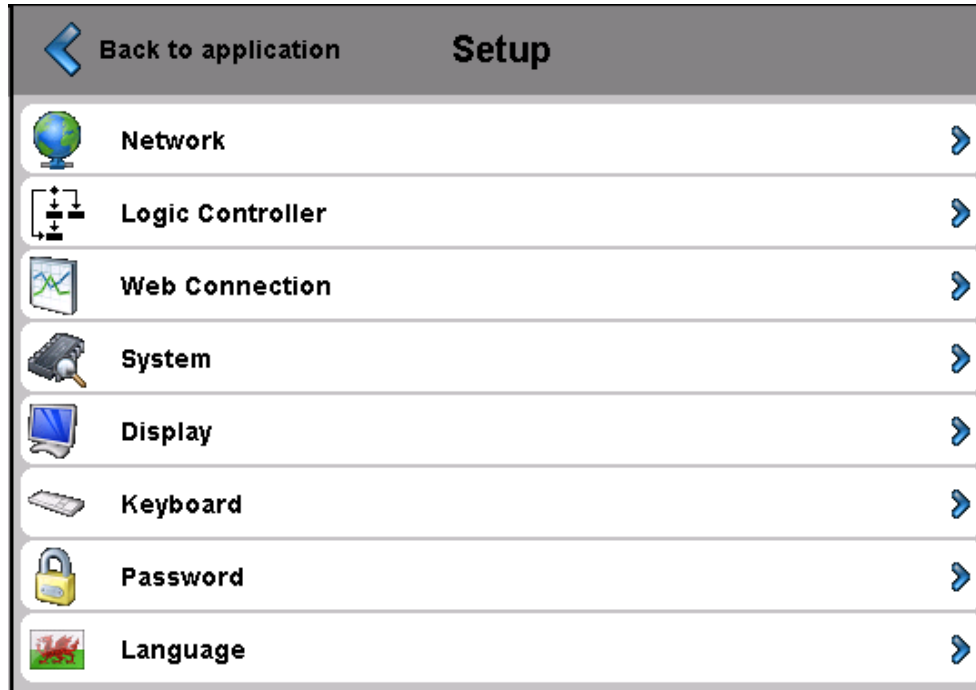

4

1	Network	MB panel settings	See section	4.1
2	Web Connection	Configure the web connection	See section	4.2
3	System	Info/Settings/Special Settings/FW download & Reboot	See section	4.3
4	Display	Display settings	See section	4.4
5	Keyboard	Virtual keyboard	See section	4.5
6	Password	Enter a password	See section	4.6
7	Language	Selection of the language (E, G, F, I and Dutch)	See section	4.7
8	Back to application	Back to application		

Network

4.1 Network

This is where you can configure the network settings for the panel. Depending on the network, the connection may also work without setting a gateway or DNS server. You can exit the menu using the Setup button.

4**4.1.1 DHCP On**

If DHCP is off, an IP must be set by the user. Otherwise all the necessary settings are acquired by the DHCP server.

4.1.2 TCP/IP address

IP address of the panel.

4.1.3 Subnet Mask

Subnet mask of the network on which the panel is located.

4.1.4 Default Gateway

IP of the standard gateway.

4.1.5 Primary DNS Server

IP of the primary DNS server.

4.1.6 Secondary DNS Server

IP of the secondary DNS server.

4.2 Web Connection



This is where you can set the data for the device from which the website is to be loaded and displayed.

4

4.2.1 Connection

Name of the connection.

4.2.2 Edit connection

4.2.2.1 Connection name

Name of the connection

4.2.2.2 Start page

Name of the start page for this connection

4.2.2.3 Remote Host IP

IP address of the connected Saia PCD.

4.2.2.4 Remote port

Remote port (80 standard)

4.2.2.5 Remote password

Server password that is required for access to the web server

4.2.3 Default password

Uses the password defined in the default connection if the current connection does not have its own password and a password is expected from the web server.

Web Connection

4.2.4 Search

Allows searching of web servers that are compatible with S-Web technology. The stations found can be copied into the connection list of the device. Information about the opposite web server/automation server can be viewed

4.2.4.1 Range Start

Start address of the search procedure.

Important: the address must be defined in the local IP address.

4

4.2.4.2 Range Size

The number of IP addresses beginning from the start address that are scanned for compatible web servers.

4.2.4.3 TCP Ports

TCP ports on which active web servers are scanned.

4.2.4.4 Result List

Compatible systems found that can be connected to the panel.

The systems found can:

- be copied into the connection list.
- Checked according to the current state and system information.

4.2.4.5 Search

Starts the search procedure. This can take some time depending on the size of the address range and number of ports.

4.2.4.6 Clear

Deletes the list of the stations found.

4.2.5 Connection List

We recommend creating one or more connections (up to 16) using the “List of connections”. Edit the connection or connections and select the connection you wish to use for your project. Each connection can be edited at any time.

Names for the connections are necessary as a URL jump target in the web editor:

Example: The connection in the list is called conn2_http, the start page of the Projekts Start.html



Web Editor 5

4

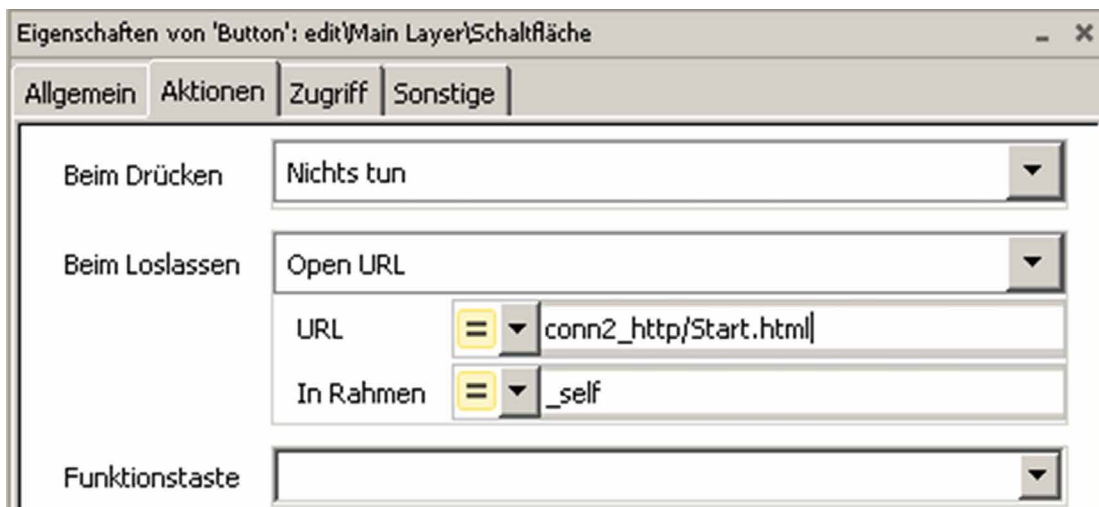

Web Editor 8

System

4.3 System



4.3.1 Info

4

System info, such as Firmware Version, Booter Version, etc.

→ **Firmware Version**

Firmware version currently installed on the panel

→ **Booter Version**

Booter version currently installed on the panel

→ **CPLD Version**

Version of the Programmable Logik Chip

→ **Expansion**

Indicates if an expansion is available, ASN and firmware version of the expansion

→ **Video Cache Permanent**

Info: permanent video cache used

→ **Erasable Video Cache**

Info: cache is used for images. Dependent upon the size and number of gif files in the cache

4.3.2 Production data

Display of the most important production data, such as serial number and ASN.

→ **ASN**

SBC product number (order number)

→ **Serial number**

Serial number of the device

→ **MAC Address**

MAC address of the device

→ **HW Version**

Hardware version of the device

→ **Production Date**

Month in which the device was produced

→ **Display Type**

Type of display (internal designation)

→ **HW LCD Rotation**

Rotation of the display

4.3.3 Settings

General settings for the panel.

→ File Search Order

Local / remote files

- **No local file search**

“No local file search” means files (.teq, .gif, etc.) are not searched for on the local server of the MB panel.

- **Local before remote**

“Local before remote” means files (.teq,.gif, etc.) are searched for first on the local server, before the PCD server is searched. Files are searched for first in INTFLASH/Webpages

- **Remote before local**

“Remote before local” means file (.teq,.gif, etc.) are searched for on the remote server, before the local server on the MB panel is searched.

→ Start Delay [s]

Start delay for restart (min. 1 sec., max. 15 sec.)

→ Start screen

Enter the greeting & modify the welcome screen

- **Startup text**

Freely-definable greeting (max. 64 characters)

- **X-position of the text**

Value between 0 and 639

- **Y-position of the text**

Value between 0 and 479

- **Name of the graphic file**

gif graphic file: INTFLASH/WEBPAGES/...

- **X-position of the graphic**

Value between 0 and 639

- **Y-position of the graphic**

Value between 0 and 479

→ File Cache Active

During normal operation, the file cache should be active.

The file cache can be activated and deactivated. Deactivation is used, for example during project handling, because changes to cached files are trackable.

→ Setup Call With Delay

Activates or deactivates the delay.

System

4

4.3.4 Special Settings

Special system settings.

→ Reset All Parameters

This command resets all parameters to the default values.

→ Format Inflash

Extended function with request for confirmation: "Do you really want to format INFLASH?" This command wipes the flash memory and recreates the file system from scratch. After the Formatting OK message, the device returns to the System menu.

→ Time

Real Time Clock (RTC)

- **Time**

Real Time Clock (RTC): enter time (container: uBT_RtcTime)

- **Date**

RTC: enter date (container: uBT_RtcDate)

- **Time Server Active**

Activates/deactivates the time server

→ Memory

Only in problem cases!

Outside of the permissible memory range → Heap 1, 2, 3 and LR.

→ Show Runtime Info

Extended command on the run time

→ FTP Server

- Switch on and off the integrated FTP server
- Port of the FTP server
- FTP user

8 FTP users can be created

An FTP user consists of a name, password, group ID, rights to groups and read or write rights

- **Name**

Freely selectable user name with which the client must log on to the FTP server.

- **Password**

The password must be at least 10 characters long and not be longer than 20 characters.

- **Group ID**

There are 5 group IDs defined. A user must be assigned a group ID. Generated files are created under this used group ID and are visible for users of this group

- **Access Group**

Allows the user to configure so that he has read rights to all group IDs.

- **Access Rights**

Allows the user to assign read or read and write rights.

→ Timeout

Timeout for which the FTP data channel is not connected to any communication

→ Maximum open connections

Maximum number of open data connections to the FTP server

→ Remove standard user

The user "root" is activated or deactivated with the password "rootpasswd"

4.3.5 Log

Clicking the button scrolls further through the list. This allows you to check, for example, if typefaces are found. The last screen gives info on error messages.

Access to log.txt via FTP: uBT_FS/LOG.TXT

4

4.3.6 Firmware download

The panel is set in bootloader mode to download new firmware

→ Download via USB

→ Download via Ethernet

4.3.7 Restart

Restarts the system.

Display

4.4 Display**4.4.1 Brightness**

Can be adjusted in a range between 0 and 20.

4**4.4.2 Backlight [min]**

The touchscreen or buttons are not selected during this period, the backlight is switched off. You can activate it again by touching the screen or a button. Can be adjusted in a range between 0 and 5000.

4.4.3 Rotation

Landscape / Portrait.

4.4.4 Calibrate Touchscreen

Carefully, using the stylus.

4.5 Keyboard



4.5.1 SIP (Virtual Keyboard)

Activates/deactivates SIP (Soft Input Panel).

Virtual Keyboard

4

4.5.2 Name of the first keyboard

You can choose from: Alphapad.teq (alphanumeric) or keypad.teq (numeric) as the first keyboard to open.

4.5.3 Width of the Focus (in Pixels)

You can select a value from 0 to 6 pixels. A frame identifies the selected area or edit field. The entry defines the frame width in pixels. At a width of 0, no frame is displayed. This is advisable if you are working only with the touchscreen.

4.6 Password



You can enter an alphabetic, numeric or alphanumeric password (maximum number of characters = 32, incl. spaces). You must confirm the password after entering it.

When you enter a new password, you have to confirm it. If the characters entered in the confirmation field do not match the new password, the old password is retained.

If you would like to disable password protection, press the Enter key and confirm without inputting any characters.



Forgot your password? → Delete the file `inflash/config/passwd.dat` (FTP connection). This will resolve your problem.

Nom	↓Ext.	Taille	Date	Attr.
↑ [-]		<RÉP>	00.00.1980 00:00----	
TSPPOINTS	DAT	48	01.01.2010 09:12-006	
PASSWD	DAT	64	01.01.2010 09:12-006	
KEYMAP	DAT	933	01.01.2010 09:12-006	

4.7 Language



You can select one of the preconfigured languages for the Setup process.

5 Local files / local server

The local FTP server is activated at the factory but without standard user and password. To access the FTP server, a user must be created or the standard user activated. (See "4.3.3 Settings" on page 4-7).

5.1 Connecting via FTP access

The internal structure can be accessed only via FTP: SBC file system (FTP access: user name and password). <ftp:// IP address>

Nom	↓Ext.	Taille
↑ [..]		<RÉP>
📁 [FILECACHE]		<RÉP>
📁 [INTFLASH]		<RÉP>
📁 [PLC_SYS]		<RÉP>
📁 [UBT_FS]		<RÉP>
📁 [WEB]		<RÉP>

5

FILE CACHE: Contains the cache memory

INTFLASH: Contains:

- **INTFLASH/CONFIG/KEYMAP.DAT** → Configure keyboard - only MB with buttons (F-keys).
Does not apply to this MB panel.
PASSWD.DAT → Only displayed if a password has been created (Forgot your password? → Delete this file.)
TSPOINTS.DAT → For internal use
- **INTFLASH/WEBPAGES** → Directory for all project files which you want to save "LOCALLY" (teq, gif files, etc.)
- **INTFLASH/FONT** → FONT directory must be created by the user. It contains all the special or additional .bft files containing typefaces.
- **INTFLASH/TRENDLOGS** → TRENDLOGS directory is created automatically when logs are stored. The .CSV files with the logs are saved to this location automatically (this uses Web Editor MB Macro S2F).
- **PLC_SYS** → Internal use, no access (configuration sett., uBT_containers, etc.)
- **UBT_FS** → **UBT_FS/LOG.TXT** List of the startup process + Error info (read, only)
- **WEB** → For internal use.
- **SLOFLASH** → Created automatically when an SD memory card is use with the SD card interface.

INTFLASH/WEBPAGES

5.2 INTFLASH/WEBPAGES

Caution: the directory name "M1_Flash" used in the SBC file system on the current QVGA and VGA MB panel no longer exists on this panel. The directory name of the root level is "INTFLASH"

5

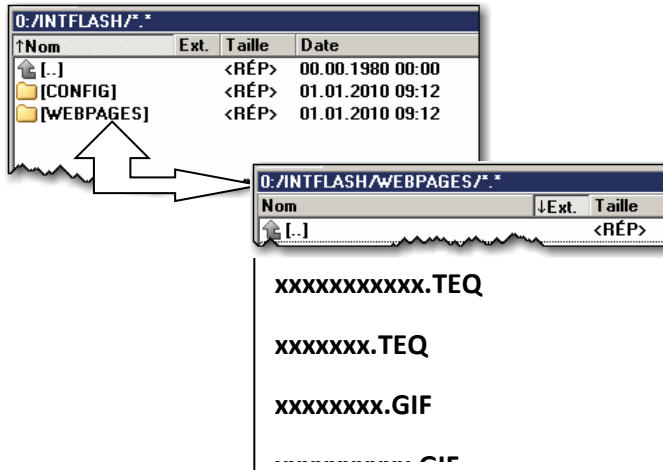

- 1) Recommended simplest method: Copy all shared files (.teq, .gif, etc.) to INTFLASH/WEBPAGES. N.B.: If you have copy .teq or .gif files (or even .itq, .csv and .html files) when using a local server, then you must always create at least one .tcr with all the PPO data (Web Builder).



Caution: Switch the Setup option from "No local file search" to "Local file search before remote"!

- 2) Copy all associated files (.teq + .gif) to the corresponding subdirectories of INTFLASH/WEBPAGES/. Each associated station has its own subdirectory. The names of the subdirectories correspond to the communication method:

HTTP direct communication → IP address of the station with an underscore instead of a dot
 e.g. IP address 192.168.12.90 becomes 192_168_12_90
 Copy files to INTFLASH/WEBPAGES/192_168_12_90



!!! → File names: max. 24 ASCII characters without spaces, including file extension.



N.B.: If you have copy .teq or .gif files (or even .itq, .csv and .html files) when using a local server, then you must always create at least one .tcr (Web Builder), as it contains all the PPO data. Do not forget to switch the Setup option from "No local file search" to "Local file search before remote".

6 Updating and special settings

6.1 Firmware update

6.1.1 Additional information on downloading FW

If problems occur while downloading via a USB connection, try the following solution:

Restart the MB panel with the USB cable REMOVED. Press the Download button and the MB panel's Download mode is activated. Next, connect the USB cable to the MB panel and press Start in the FW Download Service Program.

If problems occur while downloading via a USB or ethernet connection, try the following solution:

If communications are interrupted during the download process, no notification appears on screen. This is because the FW flash memory is erased at the start of the process.

7

6.1.2 Secure Firmware Download via USB

The secure method for downloading firmware is always via USB.

- a) Switch off the MB panel
- b) At the top of the back cover as a hole of 3 mm in diameter. It contains a button. Take a narrow-tipped pen or a small screwdriver (any cylindrical object with a diameter of 3 mm is suitable) and use it to hold down the button for short while. You can see the location of the **Reset button** in the figure:

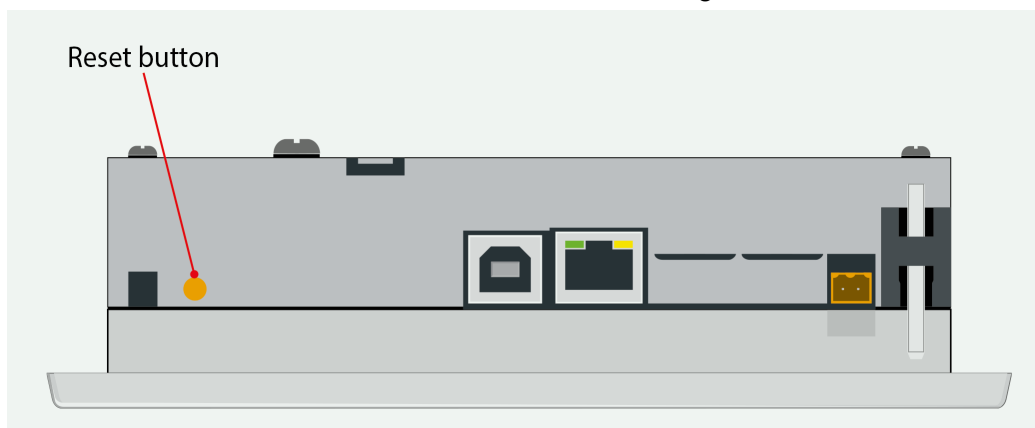

- c) Switch on the MB panel with ON at the same time. Wait 3...4 sec. until the LED starts to flash.
Then download the FW using the SBC FW Service Program.



CAUTION: The *.blk file type is used for a complete FW file. Use only those files intended for the PCD7.D4xx panel and which were supplied by Saia Burgess Controls.

6.2 Reset / Resetting the device to factory settings

In a number of particular cases, the Reset button can be used to fully reset the MB panel and restore the factory default settings.

When could this function be of use?

If, for example, you have copied the local file required for an FTP connection with the local server into the wrong directory or have unintentionally deleted data which is necessary for displaying the Setup menu. The most common error is the appearance of the message "**uBTerminal not found**", while the content on screen remains unchanged. In such a case, proceed as follows:

1. Switch off the MB panel with OFF
2. Activate the Reset button, at the top of the device's rear cover, by holding down the button (see "1.2 Definition of the connectors" on page 1-2 and "6.1.2 Secure Firmware Download via USB" on page 6-1).
Simultaneously switch on the MB panel at the same time. After approx. 30 sec., the panel goes to the reset mode.
3. Release the Reset button when the display shows the message "Booting Up" and wait.
4. You may have to wait to 1 to 2 minutes. During this time, the FW is reconstructing the whole organisation of the memory and recreating all the files which are required for the default settings. Finally, the MB panel reboots automatically, and you will be asked to recalibrate the touchscreen. Once you have calibrated it, the system has been fully restored.

7

6.3 Backlight

The period for which the backlight remains on can be set manually. This function helps to save energy. If the backlight is deactivated, you will save approx. 3/4 watts, which is a non-negligible value. This will also extend the **service life** of the backlight.

Service life of the backlight

The **normal** service life of the backlight (at 25°C) is defined as approx. 50 Kh. This corresponds to 5 years of continuous use. However, this value is **quickly reduced** (to half or less) if the operating temperature is 10°C or less. It makes sense for the user to take this into account and to adapt the standby period of the backlight accordingly.

6.4 Typefaces supported by MB panel PCD7.D4xx

Default fonts available for the VGA MB panel

	FONT SIZE						
Fonts and formats	10	12	14	16	20	24	36
Arial	x	x		x	x	x	x
Arial Bold			x		x	x	x
Courier New		x		x	x		
Courier New Bold			x		x		
Tahoma		x		x	x	x	
Tahoma Bold			x		x	x	

Calculating the given amount of play for:

Single text field, multi-line text field, edit field for text field, and button with text.

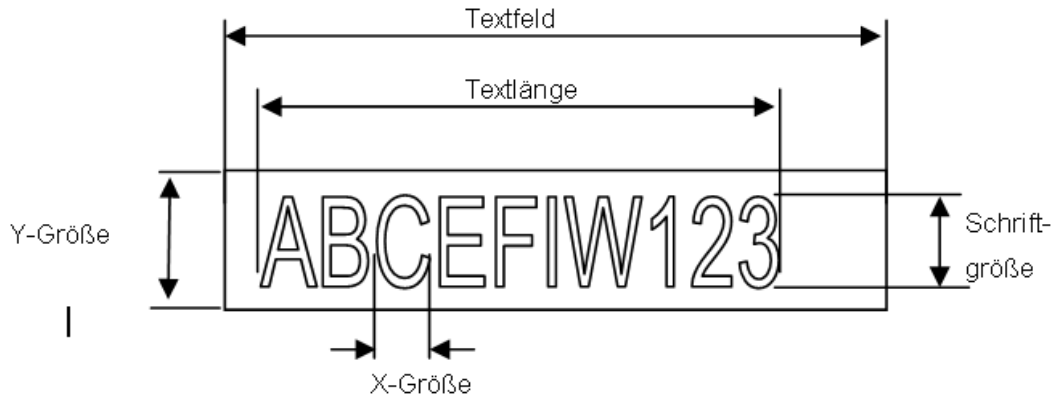

Definitions:

Font size: Character size (font size in pixels)

Y-dimension: Size of the graphical symbol (in pixels)

X-dimension: Width of a character

Text length: Length of a single-line piece of text.

Text field: Length of the painter

General recommendations for **text fields** (you can find info in the online help for the first version of Web Editor)

We recommend using text fields exceeding the size displayed in the Editor by up to 20%. To determine the text field length, you can also consult the following table of the min. and max. X-dimension.

General recommendations for the **Y-dimension** in proportion to the font size and format

Basic rule: The text should be **INSIDE** the contours.

For buttons and edit fields, a shadow of 2 pixels is added (to the **inside** of the button contours and to the **outside** of the edit fields).

If the text is too large for the edit field, it is overlaid by the border and the 3D shadow.

Typefaces supported by MB panel PCD7.D4xx

The following borders must be planned for:

- Single text fields and such with multiple lines: $2 \times \text{border width} + 1$
- Buttons: $2 \times \text{border width} + 5$
- Edit fields $2 \times \text{border width} + 5$

	Font size	ySize	min x Size	max x Size
Arial	36	41	7	36
Arial	24	28	7	24
Arial	20	23	6	20
Arial	16	19	3	16
Arial	12	15	3	12
Arial	10	12	3	10
Arial Bold	36	41	9	35
Arial Bold	24	28	7	23
Arial Bold	20	23	6	20
Arial Bold	14	16	4	15
CourierNew	20	23	12	12
CourierNew	16	19	10	10
CourierNew	12	14	7	7
CourierNew	10	12	6	6
CourierNew Bold	20	23	12	12
CourierNew Bold	14	17	8	8
Tahoma	24	29	5	24
Tahoma	20	25	4	20
Tahoma	16	20	4	16
Tahoma	12	15	4	12
Tahoma	10	13	3	10
Tahoma Bold	24	29	7	29
Tahoma Bold	20	25	6	24
Tahoma Bold	14	17	4	17

6.5 Special Unicode fonts

6.5.1 General information

The user can add additional fonts, for example, which are required for some languages or special fonts/formats/sizes, which are not provided for by default on the MB panel.

Such languages include: Russian, Greek, Chinese, Japanese, Korean.

Such fonts include: Comic sans MS, Charleworth, Book Antica, Century, Trebuchet, Verdana.

Different sizes, such as 10,12,14, etc., or formats such as plain (or normal), bold, etc., can be used on all these fonts.

Fonts and Unicode fonts: <http://www.sbc-support.ch> → Product Info → HMI → Web-Panel PCD7.D4xxx → Additional information for Sales Companies (restricted Area).

7

Files containing typefaces for specific languages or fonts/formats/sizes not appearing in the list can also be installed on an MB panel. If you want to do so, please contact SBC Support.

To ensure that all characters are supported, we recommended using the Arial typeface. This is particularly the case for languages with a large number of characters, such as Chinese.

This means using Unicode files with typefaces (.bft) generated and made available by Saia Burgess Controls. The firmware searches the following locations for typefaces:

INTFLASH/FONT

A file with typefaces contains the data for a continuous string of characters. If, for example, Greek and Cyrillic are required, two files must be loaded: one with the Greek alphabet and another containing the Cyrillic characters.

The size of such a font file must not exceed 128 kbytes.

(Chinese requires many files with different font sizes to cover all the characters.)

Special Unicode fonts

If a font file is found, it is registered. A maximum of 65 different files can be registered. When a character is required, the font file is opened and the data for the characters is called up. The data is intended for subsequent use.

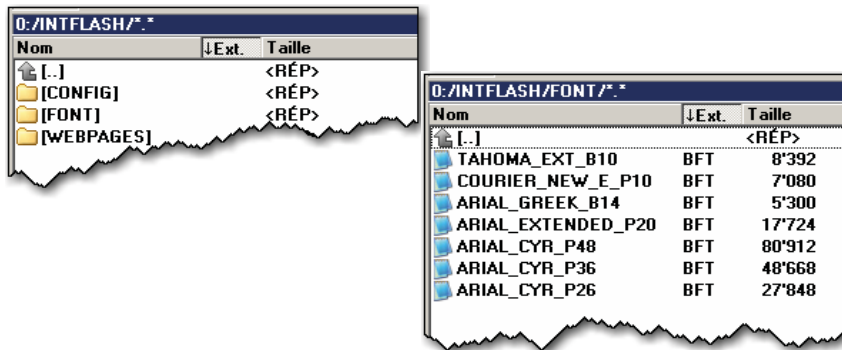

7

- Name of the font files: max. 24 ASCII characters without spaces (including file extension)
- To install font files: copy the files to the FTP server of the MB panel via an FTP connection.
- Chinese fonts: 12 is the smallest legible font size.

6.5.2 Multi-languages: Example

→ Switch to a different language with the button (set the variable with the mouse button held down).

Examples: Translate "Happy Birthday" to Czech using the "HTML TAG" type.

The Czech requires an expansion of the European characters, which can be downloaded by logging into the SBC Support site.

Procedure:

- The Unicode font .bft file(s) with expanded European character set must be copied into INTFLASH /FONT (see section "6.1 Connecting via FTP access" on page 5-1).
- Web Editor: create the static text "Happy Birthday" and select "HTML TAG" as the source type.
- Under the "Text Positions Advanced" tab for position settings: if you are using exotic characters (such as Katakana, Chinese, etc.), we recommend sticking with the default settings for the text position (not centred or justified).
- In some typefaces, it is not possible to represent all Unicode characters. We recommend using the "Arial Unicode MS" or "MS Sans Serif" typefaces, as they are well suited to use with Unicode characters.

7



Do not edit the CSV file in the S-Web Editor directly, because the text window of the S-Web Editor will save the CSV file in ASCII mode. You could, for example, use Notepad to edit your CSV files (or another text editor, which allows you to save the files in Unicode format). In the Notepad "Save As" dialog box, you can select the "Unicode" entry in the dropdown menu under "Encoding". In MS Excel, use the format "Unicode Text".

Once you have saved your CSV files in the Unicode format and selected a typeface in the HMI which can be used to display Unicode characters, then the Unicode strings should be displayed properly. If you want to use Unicode, you do not need to make any further settings in the S-Web Editor.

Special Unicode fonts

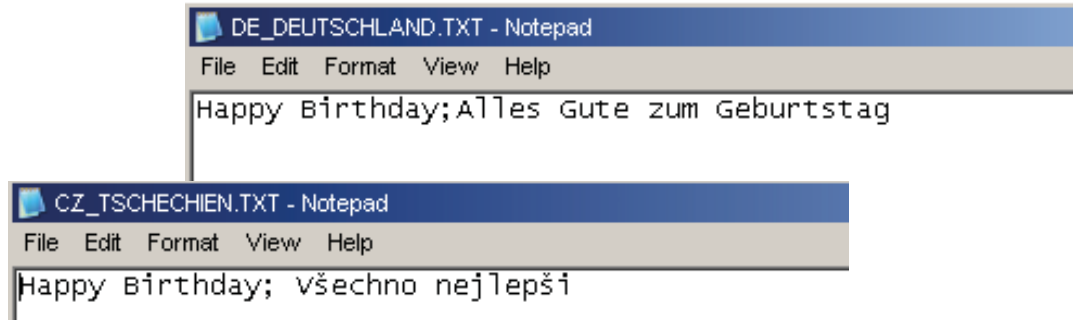

Web Editor: Create a button with the following action parameters "Actions Set Variables":

The type is the "Container", the name is "@LANGUAGE" and then the Unicode .csv file.

7

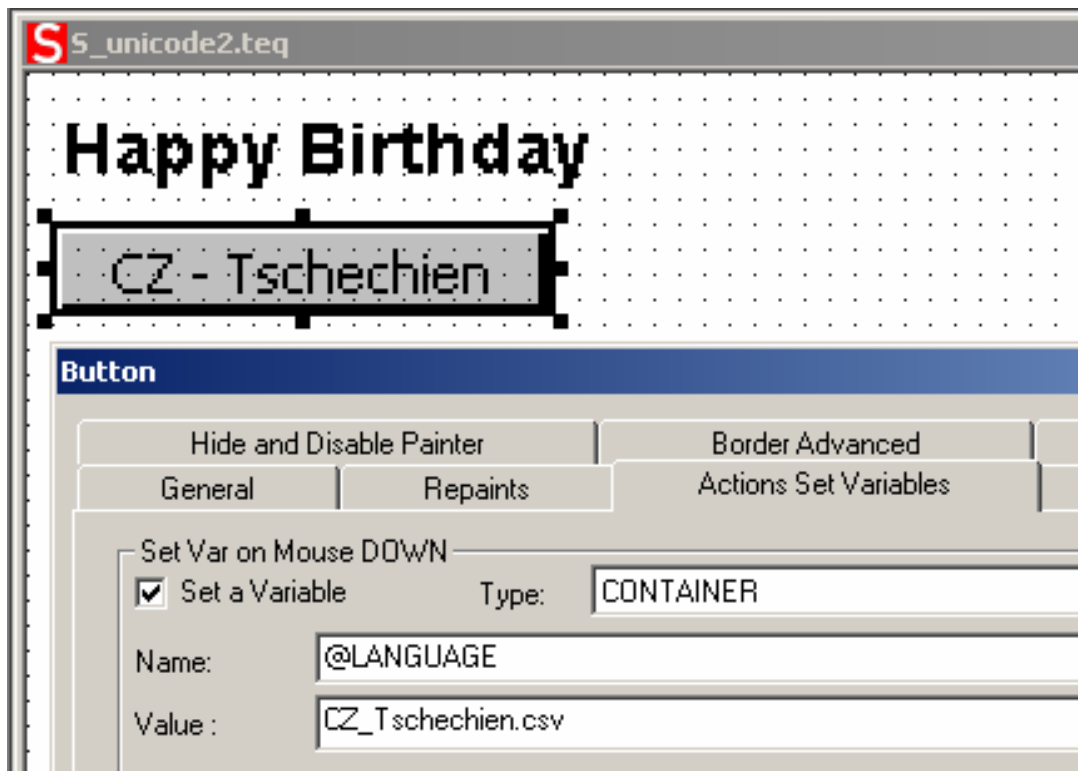

We recommend copying the .csv files into the local server of the MicroBrowser panel, under INTFLASH/ Webpages/...

→ For information on the topic of multilingual displays, see also "Multilingual HMIs" in the online help of the Web Editor.

6.5.3 Analysing incorrect fonts, font sizes or format templates

- 1 Arial, same format, **keep** size
- 2 Arial, simple, **keep** size

If the size is not available for Arial:

- 3 Same typeface, same format, **reduce size to next possible size**
- 4 Same typeface, simple, **reduce size to next possible size**

If there is no smaller typeset for this typeface:

- 5 Arial, same format, **reduce size to next possible size**
- 6 Arial, simple, **reduce size to next possible size**

If there is no smaller typeset for Arial:

- 7 Arial, same format or simple, **use the smallest available font size**

If you replace a typeset, then this is logged in the log file (See "4.3.5 Log" on page 4-9).

7

6.5.4 Web Editor

Unicode character sets are available:

- using the source type "HTML TAG" in the Web Editor and with a .CSV file.
- by entering the text directly into the Web Editor as a string. In this case, no .CSV files are necessary. Do not import any Web Editor projects created using Microsoft Windows using Unicode Character Set A into any other Windows project created using Unicode Character Set B.

Internal special functions

6.6 Internal special functions

6.6.1 Container variable for WVGA MB panel

The configuration file UBTERMINAL.TXT is not accessible via the FTP connection, because this file is located in the (write-protected) subdirectory/PLC_SYS/CONFIG/.

Containers allow the application to exchange data with the firmware. All container variables have the prefix "uBT_". Pay attention to upper/lower case!!!

Config file entry	Container (source HN 10.03.10)	Type	Default	Min value Min length	Max value Max length	Description
R/W	uBT_AlarmFrequency	Decimal value string	1000	125	8000	Frequency setting for the acoustic alarm (Hz) (based on 125,500,1000,2000,4000,8000) Set before using the alarm. A change in frequency while the alarm is sounding will take effect only when the next alarm is called.
No	uBT_AlarmStart	Decimal value string	0	0	30000 = 30 sec.	Define a value to start or stop the pulsed, acoustic alarm. The acoustic alarm can be started by setting an interval time (0 - 30,000 mSec) for the pulsed signal. A 50% pulse/pause ratio is used, i.e. the pulse time is equal to the pause time. Changes made while the alarm is already sounding are ignored. At a setting of 0, however, the alarm is immediately deactivated. The alarm is stopped immediately by touching the screen.
R/W	uBT_AlarmVolume	Decimal value string	10	0	20: 100%	Volume of the acoustic alarm (0 - 20). As pulse width modulation is used, this setting has an effect on the perceived pitch of the alarm. Set before using the alarm! A change in volume while the alarm is sounding will take effect only when the next alarm is called.
R/W	uBT_AutoRepeat	Boolean value string	0	0	1	Via the Soft Input Panel SIP (on-screen keyboard), use: SIP keyboard: AutoRepeat on (1), off (0)
No	uBT_BackLight	Boolean value string	1	0	1	Read/Write 1, 0 → Remote control for backlight OFF. The backlight is switched OFF if the value was previously '1'. When the screen is touched, the backlight is switched back on again immediately. Read/Write 0, 1 → Remote control for backlight ON. The backlight is switched ON if the value was previously '0'. There may be a delay when switching off. Remote control via PPO ← → Container coupling, only. Use on painters for buttons and edit fields is not supported.

Config file entry	Container (source HN 10.03.10)	Type	Default	Min value Min length	Max value Max length	Description
No	uBT_BackLightOn	Boolean value string	1	0	1	Direct operation of the backlight by making an entry in this container (1: On, 0: Off). Status of the backlight is set to read back. Container is set by activating the backlight by touching the screen and reset after switch off with uBT_BackLightTimeout. Areas of application: remote monitoring and remote control via PPO ↔ Container coupling, local user control right on the terminal via the painter for buttons (mouse button pressed, mouse button released) and locally via the painter for edit fields in the web project.
RW	uBT_BackLightTimeout	Decimal value string	15	0	5000	Time (min) until backlight switches off. When the screen is touched or switched on by the container, the backlight is switched on and the countdown begins. If value=0: no time-delayed monitoring of the backlight. In this case, the backlight remains permanently switched on.
Read only	uBT_BooterVersion	ANSI text string	Current version string	0	8	Firmware booter version String read, only
Read only	uBT_ConfigType	ANSI text string	Curr. config. type	0	24	Configuration type String read, only
RW	uBT_DefaultGateway	String IP address	0x00 00 00 00	*	*	Read/write IP address of the gateway on the subnet being used (forced position, overwrites default). * Setting is 0: forced position deactivated. If the setting=0: depending upon the router you are using, it may not be possible to reach external addresses outside of the subnet. If this setting is changes, a restart is necessary. This will mean FTP connections are lost.
No	uBT_DispResolution	ANSI text string	<Screen width> <Screen height> <Color depth>	0	16	Info on resolution String read, only
Yes	uBT_DisplayRotation	UTF8 1) !!! Text string	0° (0x30 C2 B0)	0°	270°	Rotation 0° 90° 180° 270° If a change is made, a restart will be necessary. This will mean FTP connections are lost. !!!! 1) Direct display of UTF8 may not be supported by the FTP client. The screen is displayed rotated, meaning that it may not be fully visible, even with automatic scaling. When the upscaling function is activated, the scaling of the non-rotating screen remains consistent with the rotating screen. Calibration of the rotating screen is the same as on the non-rotating screen. In order to alter the calibration, please return to the non-rotating screen.

Internal special functions

7

Config file entry	Container (source HN 10.03.10)	Type	Default	Min value / Min length	Max value / Max length	Description
R/W	uBT_EnableCache	Boolean value string	1 (activated)	0	1	The file cache is used (1), 0 no file cache for all visualisation files, which are not images. Files are cached for the first time as soon as they are used. Regardless of the local file settings, files are searched for first in the cache memory. The cache memory is wiped upon startup and URL jumps. Image files are decompressed and cached in a separate, always activated video cache. This video cache is wiped upon startup, URL jumps and whenever too much data has been loaded. When this occurs, all necessary files are reloaded and decompressed.
R/W	uBT_EnableSIP	Boolean value string	1 (activated)	0	1	Read/write SIP → Select the Soft Input Panel (virtual keyboard) Write 0 → SIP is deactivated. Virtual keyboards are deactivated Write 1 → SIP is activated. Virtual keyboards (alphanpad.teq and keypad.teq) are activated.
No	uBT_FlashStatus	Decimal value string	0	0	255	INTFLASH Status 20: Device present, no file system Status 21: Device present, file system OK Status 22: Device present, error during creation of file system Status 23: Device present, creation of file system in progress Status 24: Device present, compression of flash sector in progress Status - 1: Unknown error
R/W	uBT_FocusBorderWidth	Decimal value string	2	0	5	When the painter for edit fields and buttons is displayed, a rectangular focus frame indicates that it is activated. This setting is used for the line thickness (in pixels) of the focus frame: 1-5 0: Focus frame is switched off.
R/W	uBT_InactivityPollTime	ANSI text string	0	0	5	Setting for touchscreen / keyboard inactivity (1), switched off at 0. To switch to a less frequent touchscreen/keyboard call.
No	uBT_IntFlashStatus	Decimal value string	0	0	255	Status of the internal flash memory 20: Device present, no file system 21: Device present, file system OK 22: Device present, error during creation of file system 23: Device present, creation of file system in progress 24: Device present, compression of flash sector in progress -1: Unknown error
R/W	uBT_IntroGraphicName	ANSI text string	SBCSU Grande.gif	0	20	Intro graphic
R/W	uBT_IntroGraphicXPos	Decimal value string	100	0	639	Position of the intro graphic (horizontal position, from the left)
R/W	uBT_IntroGraphicYPos	Decimal value string	50	0	479	Position of the intro graphic (vertical position, from the top down)
R/W	uBT_IntroText	ANSI text string	Welcome	0	32	Startup text
R/W	uBT_IntroTextXPos	Decimal value string	350	0	639	Position of the startup text (horizontal position, from the left)
R/W	uBT_IntroTextYPos	Decimal value string	300	0	479	Position of the startup text (vertical position, from the top down)

Config file entry	Container (source HN 10.03.10)	Type	Default	Min value Min length	Max value Max length	Description
R/W	uBT_TCPIPAddr	String IP address	0xC0A8 0C 5A: 192.168 12.90	*	*	Read/write the TCP/IP address of the terminal (own address) within the subnet being used. * If the setting is changed, a restart is required. This will mean FTP connections are lost.
No	uBT_IsTSPresent	Decimal value string	Current value	0	255	Touchscreen was detected (1). If the value is 0, calibration will be skipped during startup.
R/W	uBT_LcdContrast	Decimal value string	10	0	20: 100%	Contrast and brightness setting for the backlight (0:20). Increasing the value means greater brightness.
R/W	uBT_LocalFileSearch	Decimal list string	Local before remote (1)	0	2	Search mode for local file search 0: Do not search local files 1: Search local files before remote files 2: Search remote files before local files
No	uBT_MACAddr	ANSI text string		0	20	Own MAC address (read, only)
No	uBT_MultiKeyValue	ANSI text string	0	0	1	Container is not available External SIP keyboard multikey display (1). At 0: multikey combinations not activated
R/W	uBT_S-BusAddr	Decimal value string	10	0	253	Own S-Bus address
R/W	uBT_ScaleMode	Decimal list string	Auto (0)	0	2	Setting for upscaling mode Auto (0): Smaller views are automatically adapted to the size of the terminal screen, one view at a time. QVGA views are enlarged to the full screen size of VGA terminals (2x horizontal and vertical zoom with pixel doubling). VGA (1): Forced position for VGA without upscaling of smaller views. This is why upscaling is switched off on VGA terminals. QVGA (2): Force upscaling with pixel doubling on VGA terminals. The setting takes effect on the next view jump, URL_jump, or after a restart.
Read only	uBT_SerialNumber	Hex. or dec.		0	8	Serial number (read, only)
No	uBT_Setup	Text	-	-	-	Enter "show" (pay attention to upper/lowercase). A pop-up window opens on the terminal containing the Setup menu.
R/W	uBT_SubNetMask	String IP address	0xFF FF FF 00	*	*	Read/write subnet mask of the subnet used by the terminal. * If a change is made, a restart will be necessary. This will mean FTP connections are lost.
Read only	uBT_Version	ANSI text string	Current version string	0	32	Firmware version String read, only
R/W	uBT_RtcDate	ANSI text string				The date is obtained from the real time clock on the MB panel. (Real Time Clock (RTC) must be activated in the Setup menu)
R/W	uBT_RtcTime	ANSI text string				The time is obtained from the real time clock on the MB panel. (Real Time Clock (RTC) must be activated in the Setup menu)
*: In general, IPv4 private addresses are used. The default settings are: - 1 x A class with subnet mask 10.x.x.x and mask 255.0.0.0 – sections can also be used. - 16 x B class with subnet mask 172.16.x.x to 172.31.x.x and mask 255.255.0.0 – sections or combinations can also be used. - Or 256 x C class with subnet mask 192.168.0.x to 192.168.255.x and mask 255.255.255.0 - combinations can also be used.						

Internal special functions

7

6.6.2 uBT_BackLight Containerdiagramm

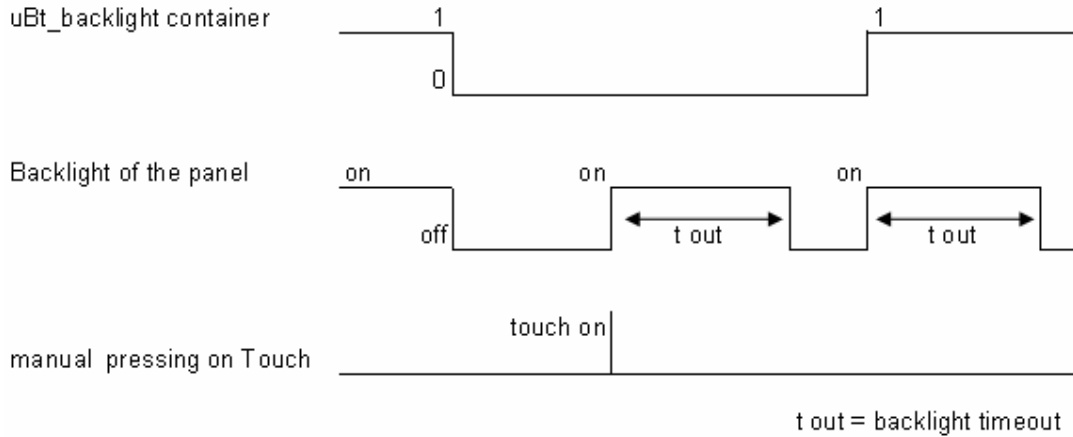

6.6.3 Additional uBTerminal container for "Save logs to File" function

Name of the container	Default	Meaning	Access
uBT_TrendPath		Dynamically chained file path	Read only
uBT_TrendDevice	INFLASH:	Power-saving device	Read only
uBT_TrendDir	WEBPAGES/TRENDLOGS	Subdirectory for storing all trends	Read
uBT_TrendSDFlash	0	0: INTFLASH (WVGA) 1: SL0FLASH* (*not on this MB panel)	Read/Write
uBT_TrendPrefix	TR	File name prefix, max. 5 characters	Read/Write
uBT_TrendSave		Last-saved file	Read only
uBT_TrendLoad		File currently loaded	Read/Write
uBT_TrendSelect	Last file in the directory	File currently selected. When saving a trend, the value is set with the saved file name.	Read/Write
uBT_TrendOldest	Change to the uBT_TrendSelect container. Used for button actions.	Select oldest file	Write only
uBT_TrendNewest		Select newest file	Write only
uBT_TrendPrev		Select previous file	Write only
uBT_TrendNext		Select next file	Write only
uBT_TrendDelAll	Use for button actions.	Delete all files in the directory	Write only
uBT_TrendDelSel		Delete currently selected file	Write only
uBT_TrendDelLast		Delete last-saved file	Write only
uBT_TrendDelOld		Delete all files which are older than the selected file.	Write only

➔ Based on the example of the online minimum S2F macros for the MB panel "MB_OnlineTrendMinimal_5_13_01.esm"
See "8.8 Trend macros for MB panels with "save logs to files"" on page 8-5.

List of message box messages

6.7 List of message box messages

Messages	Comments
Out of memory in Ramdisk	Can be displayed if a file (generally a .gif) is too large. VGA MB panel: < 256 Kb (see also section "8.6 Expanded error messages for the WVGA panel" on page 8-5)
Language	
Failed to parse .csv	No memory available for parsing a .csv file
LR: out of memory! Or out of memory for language resource	No memory available for parsing a .csv file Or the total amount of memory needed is > 512 kbytes (see also section "8.6 Expanded error messages for the WVGA panel" on page 8-5)
Failed to initialize LR heap!	The memory for the .csv file is initialised each time a file is parsed. This message means that the process has failed.
Memory	
Failed to initialize heap 1	The painter objects and the list of current PPOs are assigned to heap 1. This heap is deleted after each .teq jump.
Out of memory in heap 1	Total amount of memory used by the painters is > 1536 kbytes (see also section "8.6 Expanded error messages for the WVGA panel" on page 8-5)
Failed to initialize heap 2	Container variable, HTML tags, TCR table + Source & object display of online trends are stored in heap 2. This heap is initialised at each URL jump.
Out of memory in heap 2	The total amount of memory used by HTML tags and container variables is > 1024 kbytes. The most likely cause of this message is there being too many active offline trends. → Can be displayed for online and offline trends.
Out of memory in heap 3	→ Usually displayed due to there being too many data points. Offline trend, alarm events, HD log and online trend are stored in heap 3. Total amount of memory used by offline trend data and HD log is > 1280 kbytes (see also section "8.8 Trend macros for MB panels with "save logs to files"" on page 8-5) Before using trends, you must first calculate the amount of memory required. Online trends: If update period of process points (Web Editor parameters) = < 1000 milliseconds → (storage time in sec.) × (total number of trends) × (size of a data point → 28 Bytes) Example: 4200 sec. × 4 trends × 28 Bytes = 470 kbytes Offline trends: Macros of offline trends (with or without "save to file" function). Avoid freezing the trend lines, by pressing the Clear button in the macro upon receiving the message "out of memory in heap 3", in order to assign space in the memory to heap 3. You can then load the next files.
Object	
Maximum number of object reached!	Maximum number of objects (e.g. buttons, rectangles, etc.) in a .teq view was exceeded. Maximum objects = 512 → Siehe "8.3 Definition of an object in the Web Editor" on page 8-2.
PPO	
OrderValues on remote host has failed!	Request for the list of current PPOs from the remote host has failed.
ReadFile on remote host has failed!	Regular polling of the PPO has failed.
Communication	
buffer OVF in Spider_fileReadIn(!)	When loading the file, more data was received that the buffer is able to accept.
Range is null!	Range of a bar diagram was incorrectly calculated.
TCR	
Value out of range!	The min/max limits of a TCR value were exceeded.
Value out of default range!	Invalid value for a TCR, e.g. "aa" for time.
TEQ	
Reading UTF string failed	The end of the file was probably reached while a string was being read.

7 Handling: precautionary measures

7.1 Glass touchscreen

Since the touchscreen is pressure-resistant, you can perform actions by pushing on the screen with your finger or a stylus. Under no circumstances should you use sharp-tipped pens, which could leave behind lasting damage on the touchscreen.

The pressure required to activate the display is predefined and cannot be modified.

Never hit the touchscreen with force, as the two touchscreen layers are reinforced by a layer of glass, which could be shattered by doing so.

7.2 Information on the LCDs of the MB panel display

7

The fluid in the LCD display contains an irritant. Should this fluid come into contact with your skin, rinse the area affected under running water for at least 15 minutes.

Should fluid from the LCD display get into your eyes, rinse out your eyes under running water for at least 15 minutes and seek medical attention.

Features of the LCD display

The colours and brightness of the individual MB panel displays are individual characteristics, and may differ slightly from one display to the next.

7.3 Care

These display terminals have been developed for maintenance-free continuous operation.

Recommendations for cleaning the surface of the MB panel.

Scouring cleaning agents and/or cleaning equipment which could damage or scratch the surface of the MB panel must be avoided!

Apply denatured alcohol to a clean, soft cloth.

Finish by wiping it down with clean water and a clean, soft cloth (recommended).

During cleaning, make sure that no liquids of any kind are allowed to penetrate inside the panel. Resistant to chemical substances according to DIN42115.

7

8 General recommendations for the Web Editor 5

8.1 In the "Project configurations"

→ Select a standard typeface to be used for most projects!

8.2 In the Web Editor project (general information)

- It is recommended to use text fields, which exceed the size displayed in the Editor by up to 20%. You can find details in section "6.4 Typefaces supported by MB panel PCD7.D4xx" on page 6-3.
- IMasterSaia5_xx_xx.jar is not required in order to display a website on the MB panel.
- The .tcr file is the only file which needs to be integrated into the Web Server project (.wsp). All other project files can be copied into the flash memory (PLC or local server of the MB panel) under INFLASH/webpages/.
- Add Unicode fonts → Consult: <http://www.sbc-support.com> → Product Info → HMI → Web-Panel PCD7.D4xxx → Additional information for Sales Companies (restricted area)
- If the correct typeface is not in the list → please contact PCD Support in Murten, where we would be happy to help.
- The container offset name (container name) must not contain any underscores or @ signs (i.e., not: PDP-ADDRESS+@COFF_containername@, PDP-FORMAT).
- Consider that the suffix for container offset is d for a decimal and k for the format HH:MM
- Use "Online trends macros" with the right timestamp: The time server must be activated in the Setup menu.
- For information on calculating the amount of memory required, see "6.7 List of message box messages" on page 6-16 and "8.5.3 Decompression of Gif files: analysis/calculation" on page 8-4.
- Viewing angle: the surface (front panel of the unit) projects a few millimetres over the display. You should therefore leave a frame of 4-5 pixels free (black) around the view.
- PPOs: → Number of objects per page: tested with 1024 objects (1024 objects with 3 flags per object = 3072 flags)
- PPOs: → Number of registers per page: tested with 475 registers
- Maximum number of objects (painters) per page is 512 objects
- Project configuration → Scaleable HTML: define HTMLs, where the HMI is adjusted during the run time by a defined factor. For example, scale your HMI to 200%, without having to modify the TEQ views. MicroBrowser adapts the TEQ views during run time if you enter your new 'scaleable' HTML file instead of the standard HTML file.
Examples: Factor 2.000000 means 200% of 640 × 480, i.e. 1280 × 960;
a factor < 1 (< 100%) is not suitable for applications with the MB panel.

8.3 Definition of an object in the Web Editor

- An object is a static text component, a multiline label, a line, a rectangle, an ellipse, a polygon, an edit field, a button, or a bar chart. Macros contain many objects (an offline trend contains 44 objects).

8.4 Handling

- Touchscreen: The base material of the touchscreen is glass. For this reason, you should therefore not touch the screen with a screwdriver or hard objects, which could damage the screen. Use only a finger or special input stylus for operation.
- In addition: use the right tool for a hardware reset(see "6.2 Reset / Resetting the device to factory settings" on page 6-2). Do not use a paperclip or pin, but rather push the microswitch carefully with a Ø 3 mm drill bit.

8

8.5 Some rules regarding gif images

- The three timestamps on the MB panel's graphical display are:
 - Repaint video cache
 - Decompression in the video cache in case of URL jump and after startup (almost linear with the number of pixels). See "8.5.3 Decompression of Gif files: analysis/calculation" on page 8-4.
 - File transfer time via the link if not local.
- If the total size of the gif files is the same, one large image (max. 512 kbytes) is better than two smaller ones.
Recommended max. size 798 × 598 pixels (one pixel remains free all-around).
- It is better to use the same image multiple times in the same project, because it then has to be transferred only once, decompressed and stored in the video cache. Place it, for example, in the teq file for the general background.

8.5.1 Decompression in the video cache at startup using the Gif list

This solution allows gif files to be decompressed in the video cache in the background.

Advantage: You do not have to wait for decompression to finish until the first page can be displayed.

The first page is displayed immediately (as with a project with no gif list) and you do not have to wait until all gif files in the gif list have been decompressed. Decompression continues in the background until the video memory is full (if there are multiple gif files in the gif list). See "8.5.3 Decompression of Gif files: analysis/calculation" on page 8-4.

Operation of:

- Open Microsoft® Notepad Editor
- Write the following header text for the file:
 - [PATH]
 - INTFLASH:/WebPages
 - [FILE]
- Enter the name of all gif files (as listed in the local directory INTFLASH/WebPages).
- Save the file under the name "GifList.txt".
- Example of a GifList.txt:

```

[[PATH]
INTFLASH:/webPages
[FILE]
A_SETTINGS.GIF
A_WATER_IA.GIF
B_ALARM.GIF
B_ALARM_A.GIF
B_BACK.GIF
B_CLIMATE_A.GIF
B_CLIMATE_A_DE.GIF
B_CLIMATE_A_EN.GIF
B_CLIMATE_A_FR.GIF
B_CLIMATE_A_IT.GIF
B_CLIMATE_DE.GIF
B_CLIMATE_EN.GIF
B_CLIMATE_FR.GIF
B_CLIMATE_IA.GIF
B_CLIMATE_IA_DE.GIF
B_CLIMATE_IA_EN.GIF
B_CLIMATE_IA_FR.GIF
B_CLIMATE_IA_IT.GIF
B_CLIMATE_IT.GIF
B_CLOCK.GIF
B_ELECTRO_A.GIF
    
```

- Copy of the GifList.txt under INTFLASH/Config/

D:/INTFLASH/CONFIG/*.*		
Nom	Ext.	Taille
[..]		<RÉP>
GIFLIST	TXT	178
TSPPOINTS	DAT	48
KEYMAP	DAT	933

- For checking in LOG.TXT (UBT_FS/LOG.TXT)

```

Untitled - Notepad
File Edit Format View Help
0x00004686 Start Process Gif
0x0000468C [PATH]
0x00004690 INTFLASH:/webPages
0x00004694 [FILE]
0x00004B81 Stop Process Gif
    
```

8.5.2 Decompression of Gif files in the video cache at startup using a dummy start screen

→ Place all the gifs in a teq start screen, which will serve as a placeholder.

This solution allows you to decompress gif files in the video cache before the real first page of the project is displayed.

Advantage: Decompression is already finished when the first page of the project is displayed.

Disadvantage: You have to wait for compression to finish, before the first page is displayed.

Tip: Create a dummy page with:
 ...a messages such as "Images loading, please wait."
 ...the View Jump_onTimeout macro to jump to the correct first page of the project

8

8.5.3 Decompression of Gif files: analysis/calculation

Available for the solutions from sections "8.5.1 Decompression in the video cache at startup using the Gif list" on page 8-3 and "8.5.2 Decompression of Gif files in the video cache at startup" on page 8-4.

How do you analyse the number of gifs in the video cache, based on the number of pixels in the gif images? The video cache has a total size (permanent and flushable) of 16 MByte. Of this, 4 to 6 Mbyte are used for the permanent cache. The remaining ~ 10...12 Mbyte are available.

Example calculation of the number of images in the 4 Mbyte permanent video cache

Example 1: The number of pixels in the images is 640 × 480 pixels (the whole screen)
 $12\,000\,000 \text{ Byte} / (640 \times 480) \times 2 = 19.53125$
 That means, that the cache can hold a maximum of 19 gif files.

Example 2: The number of pixels in the images is ~ 120 × 120 pixels
 $12\,000\,000 \text{ Byte} / (120 \times 120) \times 2 = 416\frac{2}{3}$
 That means, that the cache can hold a maximum of 400 gif files.



Note: The ratio between the size of the gif files and the number of pixels is not a constant.

8.6 Expanded error messages for the WVGA panel

Other: The following messages * can be displayed if the amount of memory required by the gif files, painters, HTML tags, container variables, online /offline trends, HD logs, and language resources (.csv files) is too large. In this case, some parameters must be adjusted by modifying their values directly in the Setup menu (see "4.3.3 Settings" on page 4-7)! After making modifications, the panel must be restarted.

Recommendations:

We do not recommend setting the maximum value immediately, but rather first trying a moderate value, as problems could occur and performance is substantially reduced by setting all the memory values to their maximum value.

Error messages *	Default values	Moderate values	Maximum values
■ out of memory in ramdisk	512 kbytes	640 kbytes	1024 kbytes
■ out of memory in heap 1	1536 kbytes	792 kbytes	2048 kbytes
■ out of memory in heap 2	1024 kbytes	2048 kbytes	4096 kbytes
■ out of memory in heap 3	1280 kbytes	2048 kbytes	4096 kbytes
■ out of memory for language resource (or LR: out of memory)	512 kbytes	768 kbytes	1024 kbytes

8.7 Extended alarm macros

8.8 Trend macros for MB panels with "save logs to files"

The Web Editor macro library does not contain any special trend macros with S2F (save to files) for MicroBrowser panels*. These macros must, for the moment, be downloaded on the Support screen, and will only be integrated in the next version of PG5.

- These trend macros are 100% based on the default trend macros (minimum and complete) with some additional edit fields and buttons (container variables), which allow for display and management functionality, and if necessary for the deletion of csv files.
- The names of the macros are identical to the default macros and have the prefix "MB_"
- The online and offline trend logos can be saved as a "CSV format file" on the MB panel itself, and be played back there. These .CSV files can be read as text via FTP access, and are stored on the MB panel in a subdirectory of INTFLASH/WEBPAGES/ "TRENDLOGS" (or optionally on the SD memory card).
- The name of the CSV file is created automatically up to a prefix of max. 5 characters. The name contains the full date when the file was created: Day, Month, Day and Hour/Minute/Second.

Examples: TR_20110713081305.CSV (TR_ is the prefix).

Web Editor





After downloading the macro, create two subdirectories and copy them.

MacroLib/SBCTrendMacro/MB_ trend macros with S2F

MacroLib/ SBCHDLogTrendMacro/MB_ HDlog macros with S2F

→ MacroLib /SBCTrendMacro/MB_ trend macros with S2F

The applies to "Online Trends", "Offline Trends" (DBs) and "Offline Saved Trends", which allow you to play back all of the stored files.

 MB_OnlineTrendComplete_S2F_5_13_01	esm
 MB_OfflineTrendMinimal_S2F_5_13_01	esm
 MB_OfflineTrendComplete_S2F_5_13_01	esm
 MB_OfflineSavedTrendMinimal_S2F_5_13_01	esm
 MB_OfflineSavedTrendComplete_S2F_5_13_01	esm

→ MacroLib/SBCHDLogTrendMacro / MB_ HDlog macros with S2F

This applies to "Remote Offline Saved Trends" (HDlog macros)

 MB_RemoteOffSavedTrdMini_S2F_5_14_25	esm
 MB_RemoteOffSavedTrdComplete_S2F_5_14_25	esm

Section "6.6.3 Additional uBTerminal container for "Save logs to File" function" on page 6-15 shows a list of the containers, which are required by the individual MB_ Trends.

MB panels → Example of teq trend view with "MB_OnlineTrendMinimal_S2F_5_13_01.esm"

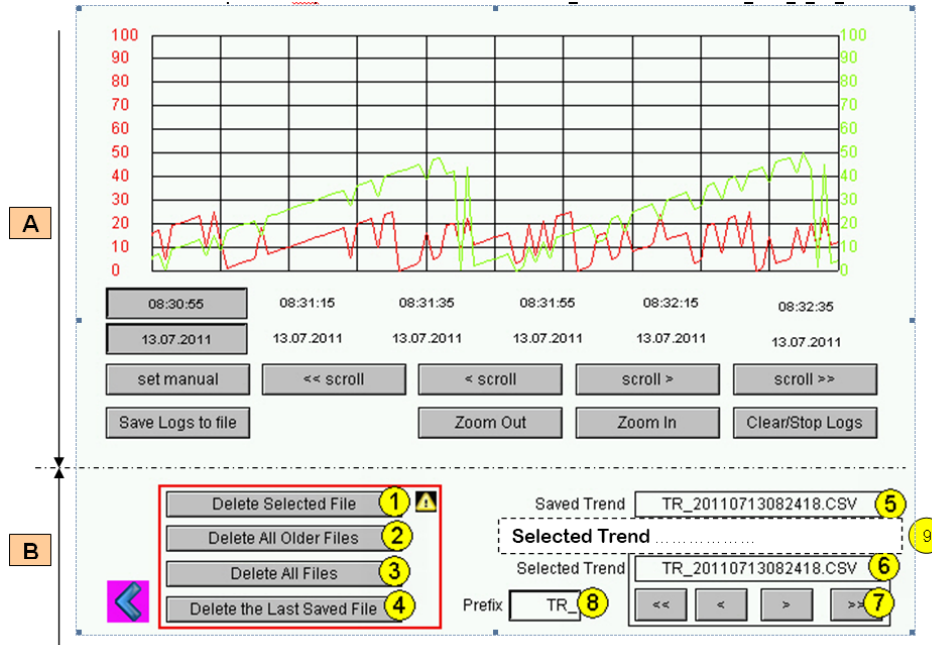

A	Standard Online Trend Minimal macro	
B	Additional buttons and edit fields for: displaying saved file names, list of saved file as well as navigating within the list if .CSV files.	
1)	Delete selected File	Delete the selected file (6).
2)	Delete All Older files	Delete files which are older than the selected file.
3)	Delete All files	Delete all saved files.
4)	Delete the last Saved File	Delete the last saved file.
5)	Saved Trend	Full name of the last saved file.
6)	Selected Trend	Newest file in the directory. Navigate through the list of saved files, using the buttons, and select one of them.
7)	<<<>>>	Navigate through the list of files with the same prefix.
8)	Prefix name	Free characters, which are available as a prefix (max. 5 characters). Do not modify the prefix name between the login processes. Such carelessness can cause problems. The name is used to identify a group of .CSV files.
9)	Loaded Trend	Not in the online trend, but only with the MB_Offline-SavedTrend macros! Name of the selected and loaded file.

Important information: Depending upon the application, many buttons or edit fields may be unnecessary.

Procedure: Remove the edit fields for macro and delete buttons, which cannot be used, from the group. Regroup the fields.

Example: The edit field given the prefix in its name can be removed without impacting the trend function.

You can also reorganise the macro: increase button size. The position of the date and time (X-axis) must not be changed (inverted).

FTP access





By selecting FTP access, you can display and read the list of .CSV files.

In INTFLASH/TRENDLOGS/

O:/INTFLASH/WEBPAGES/TRENDLOGS/*.*					
Nom	↑Ext.	Taille	Date	Attr.	
[.]		<REP>	00.00.1980	00:00---	
TR_20110713164604	CSV	1'026	01.01.2011	09:12-006	
TR_20110713164628	CSV	2'447	01.01.2011	09:12-006	
TR_20110713164734	CSV	1'149	01.01.2011	09:12-006	
TR_20110713164800	CSV	1'249	01.01.2011	09:12-006	
TR_20110713164829	CSV	1'444	01.01.2011	09:12-006	
TR_20110713164918	CSV	1'071	01.01.2011	09:12-006	

A Appendix

A.1 Icons

	<p>In manuals, this symbol refers the reader to further information in this manual or other manuals or technical information documents. As a rule there is no direct link to such documents.</p>
	<p>This symbol warns the reader of the risk to components from electrostatic discharges caused by touch. Recommendation: Before coming into contact with electrical components, you should at least touch the Minus of the system (cabinet of PGU connector). It is better to use a grounding wrist strap with its cable permanently attached to the Minus of the system.</p>
	<p>This sign accompanies instructions that must always be followed.</p>
	<p>Explanations beside this sign are valid only for the Saia PCD® Classic series.</p>
	<p>Explanations beside this sign are valid only for the Saia PCD® xx7 series.</p>

Safety information

A.2 Safety information**ATTENTION**

These devices must only be installed by a professional electrician, otherwise there is the risk of fire or the risk of an electric shock.

**WARNING**

Product is not intended to be used in safety critical applications, using it in safety critical applications is unsafe.

**WARNING - Safety**

The unit is not suitable for the explosion-proof areas and the areas of use excluded in EN61010 Part 1.

**WARNING - Safety**

Check compliance with nominal voltage before commissioning the device (see type label). Check that connection cables are free from damage and that, when wiring up the device, they are not connected to voltage. Do not use a damaged device!

**NOTE**

In order to avoid moisture in the device due to condensate build-up, acclimatise the device at room temperature for about half an hour before connecting.

**CLEANING**

The device can be cleaned in dead state with a dry cloth or cloth soaked in soap solution. Do not use caustic or solvent-containing substances for cleaning.

**MAINTENANCE**

These devices are maintenance-free. If damaged during transportation or storage, no repairs should be undertaken by the user.

**GUARANTEE**

Opening the module invalidates the guarantee.

A

EAC Mark of Conformity for Machinery Exports to Russia, Kazakhstan or Belarus.

A.3 Waste of Electrical and Electronic Equipment (WEEE) disposal

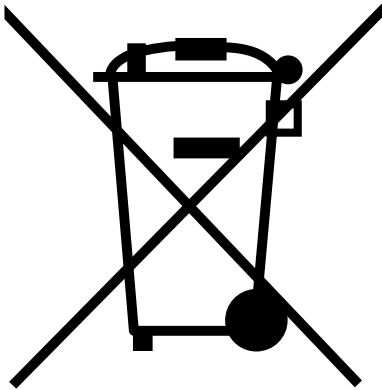

WEEE Directive 2012/19/EC Waste Electrical and Electronic Equipment directive

This symbol on our product shows a crossed-out “wheelie-bin” as required by law regarding the Waste of Electrical and Electronic Equipment (WEEE) disposal. This indicates your responsibility to contribute in protecting the environment by proper disposal of this waste, i.e., not disposing of this product with your other wastes. To know the right disposal mechanism, please check the applicable law.”

Address of Saia Burgess Controls

A.4 Contact**Saia-Burgess Controls AG**

Bahnhofstrasse 18
3280 Murten
Switzerland

Phone..... +41 26 580 30 00

Fax..... +41 26 580 34 99

Email support: support@saia-pcd.com

Supportsite: www.sbc-support.com

SBC site: www.saia-pcd.com

International Representatives &

SBC Sales Companies: www.saia-pcd.com/contact

Postal address for returns from customers of the Swiss Sales office**Saia-Burgess Controls AG**

Service Après-Vente
Bahnhofstrasse 18
3280 Murten
Switzerland

Saia-Burgess Controls AG

Bahnhofstrasse 18
3280 Murten
Switzerland

T +41 26 580 30 00

F +41 26 580 34 99

A

www.saia-pcd.com
info.ch@saia-pcd.com
www.sbc-support.com

Honeywell | Partner Channel

