

Honeywell

HVAC232/402

Honeywell

THE POWER OF **CONNECTED**

APPLICATION MANUAL

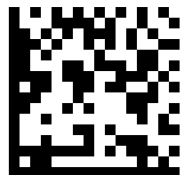

27-652_ENG06

Content

0	DOCUMENT HYSTORY	5
1	SAFETY	6
1.1	Warnings	7
1.2	Safety instructions	8
1.3	Earthing and earth fault protection	9
1.4	Before running the motor	10
2	RECEIPT OF DELIVERY	10
2.1	Storage	10
2.2	Maintenance	10
2.3	Warranty	11
3	INSTALLATION	11
3.1	Mechanical installation	11
3.2	HVAC232/402 dimensions	14
3.3	Cooling	17
3.4	Power losses	18
3.5	EMC levels	21
3.6	Changing the EMC protection class from C2 to C4	22
3.7	Cabling and connections	23
3.8	Screw of cables	28
3.9	Stripping lengths of motor and mains cables	31
3.10	Cable installation	32
3.11	Cable and motor insulation checks	32
4	COMMISSIONING AND START-UP WIZARD	32
4.1	Commissioning steps of HVAC232/402	32
4.2	Startup Wizard	34

5	FAULT TRACING	35
6	HVAC232/402 APPLICATION INTERFACE	41
6.1	Introduction	41
6.2	Control I/O	42
7	CONTROL PANEL	44
7.1	General	44
7.2	Display	44
7.3	Keypad	46
8	NAVIGATION ON THE HVAC232/402 CONTROL PANEL	47
8.1	Main menu	47
8.2	Reference menu	49
8.3	Monitoring menu	50
8.4	Parameter menu	53
8.5	System menu	54
9	Standard application parameters	55
9.1	Quick setup parameters (Virtual menu, shows when par. 16.2 → 1)	56
9.2	Easy usage menu (Control panel: Menu PAR → P16)	89
9.3	Fire mode (Control panel: Menu PAR → P18)	90

10	Parameter description	96
10.1	Motor settings (Control panel: Menu PAR → P1)	96
10.2	Start / stop setup (Control panel: Menu PAR → P2)	101
10.3	Frequency references (Control panel: Menu PAR → P3)	112
10.4	Ramps & brakes setup (Control panel: Menu PAR → P4)	114
10.5	Digital inputs (Control panel: Menu PAR → P5)	117
10.6	Analogue inputs (Control panel: Menu PAR → P6)	118
10.7	Digital outputs (Control panel: Menu PAR → P7)	119
10.8	Analogue outputs (Control panel: Menu PAR → P8)	120
10.9	Fieldbus Data-Mapping (Control panel: Menu PAR → P9)	120
10.10	Prohibited Frequencies (Control panel: Menu PAR → P10)	121
10.11	Protections (Control panel: Menu Par → P12)	122
10.12	Automatic reset (Control panel: Menu PAR → P13)	127
10.13	PID control parameters (Control panel: Menu PAR → P14)	128
10.14	Application setting (Control panel: Menu PAR → P15)	130
10.15	Application setting (Control panel: Menu PAR → P16)	131
10.16	System parameter	132
10.17	Modbus RTU	133
10.18	Termination resistor	134
10.19	Modbus address area	134
10.20	Modbus process data	134
11	Technical data	138
11.1	HVAC232/402 technical data	138
12	PART NUMBERS, POWER RATINGS, SIZE, AND WEIGHT	141
12.1	Part Number Options	141
12.2	Low overload	142
12.3	High overload	142
12.4	HVAC232/402 – Mains voltage 208-240 V	143
13	ACCESSORIES	145

0 DOCUMENT HYSTORY

Version	Date	Modifications
ENG06	2019-08-07	Table 54 : Modbus: Input process data: ID2003 new Name "Frequency reference" and new Type "0...10'000"

1 SAFETY

Please read the information included in cautions and warnings carefully:



CAUTION

ONLY A COMPETENT ELECTRICIAN IS ALLOWED TO CARRY OUT THE ELECTRICAL INSTALLATION!

This manual contains clearly marked cautions and warnings which are intended for your personal safety and to avoid any unintentional damage to the product or connected appliances.

1.1 Warnings



WARNING

The components of the power unit of the frequency converter are live when HVAC232/402 is connected to mains. Coming into contact with this voltage is extremely dangerous and may cause death or severe injury. The control unit is isolated from the mains potential.



WARNING

If the frequency converter is used as a part of a machine, the machine manufacturer is responsible for providing the machine with a main switch (EN 60204-1).



WARNING

The motor terminals U, V, W (T1, T2, T3) and the possible brake resistor terminals / + are live when HVAC232/402 is connected to mains, even if the motor is not running.



WARNING

If HVAC232/402 is disconnected from mains while running the motor, it remains live if the motor is energized by the process. In this case the motor functions as a generator feeding energy to the frequency converter.



WARNING

The control I/O-terminals are isolated from the mains potential. However, the relay output terminals may have a dangerous control voltage present even when HVAC232/402 is disconnected from mains.



WARNING

After disconnecting the frequency converter from the mains, wait until the fan stops and the indicators on the display go out. Wait 5 more minutes before doing any work on HVAC232/402 connections.



WARNING

The earth leakage current of HVAC232/402 frequency converters exceeds 3.5 mA AC. According to standard EN61800- 5-1, a reinforced protective ground connection must be ensured.



WARNING

The motor can start automatically after a fault situation, if the autoreset function has been activated.

1.2 Safety instructions



CAUTION

The HVAC232/402 frequency converter has been designed for fixed installations only.



CAUTION

Prior to measurements on the motor or the motor cable, disconnect the motor cable from the frequency converter.



CAUTION

Do not perform any measurements when the frequency converter is connected to the mains.



CAUTION

Do not open the cover of HVAC232/402. Static voltage discharge from your fingers may damage the components. Opening the cover may also damage the device. If the cover of HVAC232/402 is opened, warranty becomes void.



CAUTION

Do not perform any voltage withstand tests on any part of HVAC232/402.
The product safety is fully tested at factory.

1.3 Earthing and earth fault protection

The Smart HVAC232/402 frequency converter **must always be** earthed with an earthing conductor connected to the earthing terminal. See figure below:

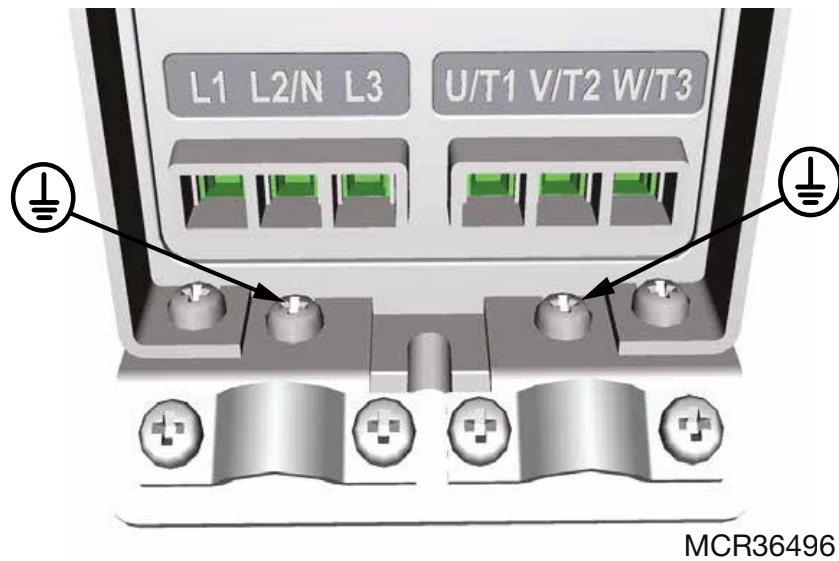

Fig. 1. MI1 - MI3



Fig. 2. MI4

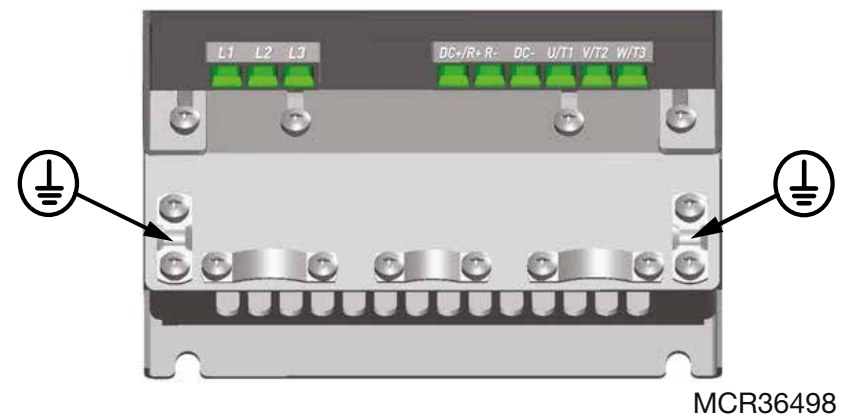

Fig. 3. MI5

1. The earth fault protection inside the frequency converter protects only the converter itself against earth faults.
2. If residual current devices are used they must be tested with the drive with earth fault currents that are possible to arise in fault situations.

1.4 Before running the motor

Checklist:

- ❑ Before starting the motor, check that the motor is mounted properly and ensure that the machine connected to the motor allows the motor to be started.
- ❑ Set the maximum motor speed(frequency) according to the motor and the machine connected to it.
- ❑ Before reversing the motor shaft rotation direction make sure that this can be done safely.
- ❑ Make sure that no power correction capacitors are connected to the motor cable.

2 RECEIPT OF DELIVERY

After unpacking the product, check that no signs of transport damages are to be found on the product and that the delivery is complete (compare the type designation of the product to the code: see chapter 12).

Should the drive have been damaged during the shipping, please contact primarily the cargo insurance company or the carrier.

If the delivery does not correspond to your order, contact the supplier immediately.

2.1 Storage

If the frequency converter is to be kept in store before use make sure that the ambient conditions are acceptable:

Storing temperature -40 °F (-40 °C)...+70 °F (21 °C)

Relative humidity < 95%, no condensation

2.2 Maintenance

In normal operating conditions, HVAC232/402 frequency converters are maintenance- free. However, regular maintenance is recommended to ensure a trouble-free operating and along lifetime of the drive. We recommended to follow the table below for maintenance intervals.

Table 1.

Maintenance interval	Maintenance action
Whenever necessary	Clean heat sink*
Regular	Check tightening torques of terminals
12 months (If stored)	Check input and output terminals and control I/O terminals. Clean cooling tunnel.* Check operation of cooling fan. Check for corrosion on terminals, bus bars and other surfaces.*
6 - 24 months (depending on environment)	Check and clean cooling fans: <ul style="list-style-type: none">• Main fan*• Internal fan*

* Only for frame 4 and frame 5

Capacitor recharge

After a longer storage time the capacitors need to be recharge in order to avoid capacitor damage. Possible high leakage current through the capacitors must be limited. The best way to achieve this is to use a DC-power supply with adjustable current limit.

1. Set the current limit to 300...800 mA according to the size of the drive.
2. Then connect the DC-power supply to the input phase L1 and L2.
3. Then set the DC-voltage to the nominal DC- voltage level of the $(1.35 \times U_n \text{ AC})$ and supply the converter for at least 1h.If DC-voltage is not available and the unit has been stored much longer than 12 months de-energized, consult the factory before connecting power.

2.3 Warranty

Only manufacturing defects are covered by the warranty. The manufacturer assumes no responsibility for damages caused during or resulting from transport, receipt of the delivery, installation, commissioning or use.

The manufacturer shall in no event and under no circumstances be held responsible for damages and failures resulting from misuse, wrong installation, unacceptable ambient temperature, dust, corrosive substances or operation outside the rated specifications. Neither can the manufacturer be held responsible for consequential damages.

Variable frequency drive devices (VFD) and accessories: new products for thirty-six (30) months from the date of production.

3 INSTALLATION

3.1 Mechanical installation

There are two possible ways to mount HVAC232/402 in the wall. For MI1-MI3, either screw or DIN-rail mounting; For MI4-MI5, screw or flange mounting.

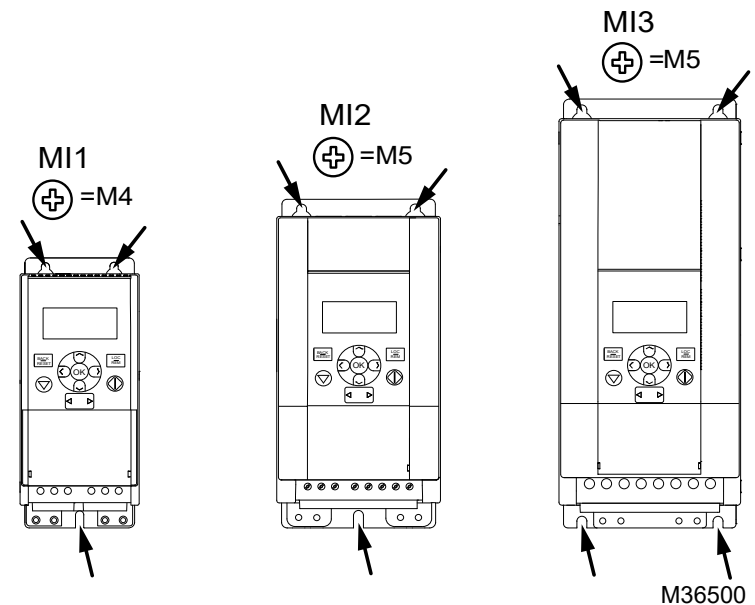

Fig. 4. Screw mounting, MI1 - MI3

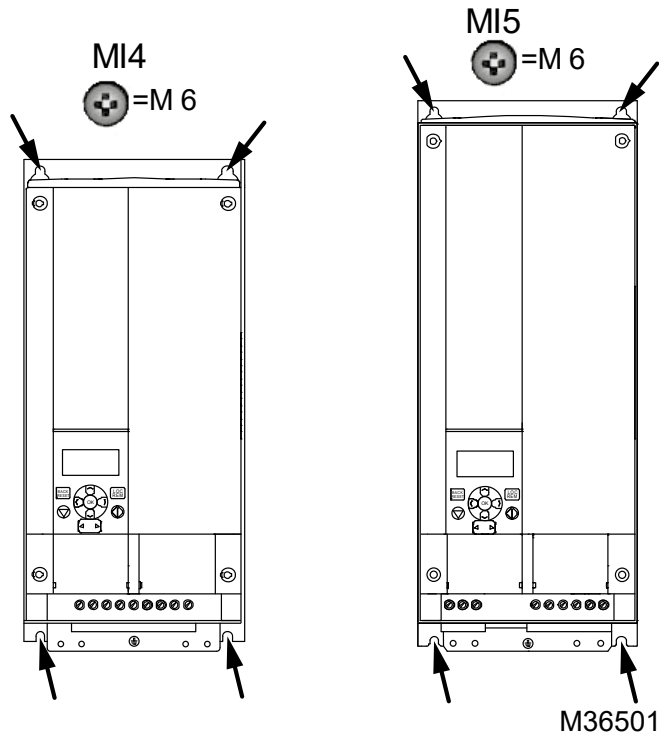

Fig. 5. Screw mounting, MI4 - MI5

i NOTE:
See the mounting dimensions on the back of the drive.

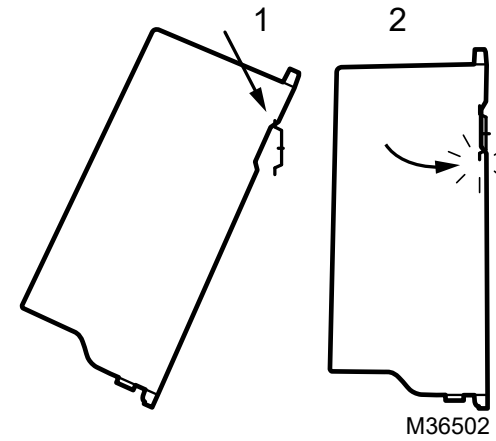

Fig. 6. DIN-rail mounting, MI1 - MI3

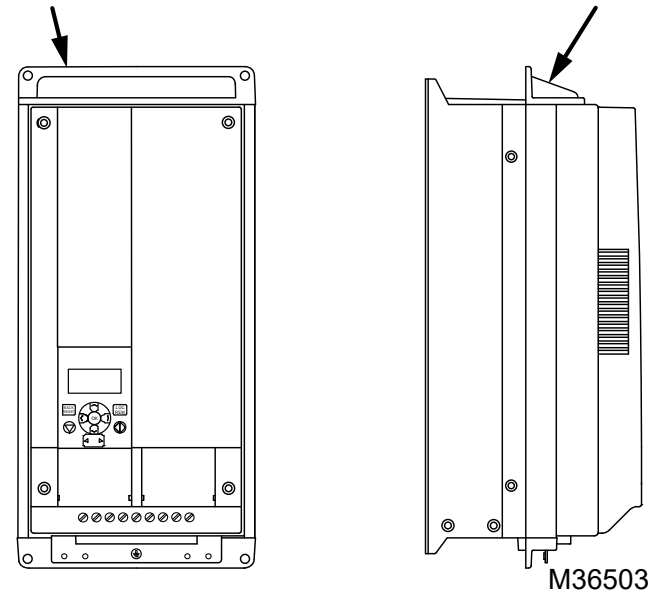

Fig. 7. Flange mounting, MI4 - MI5

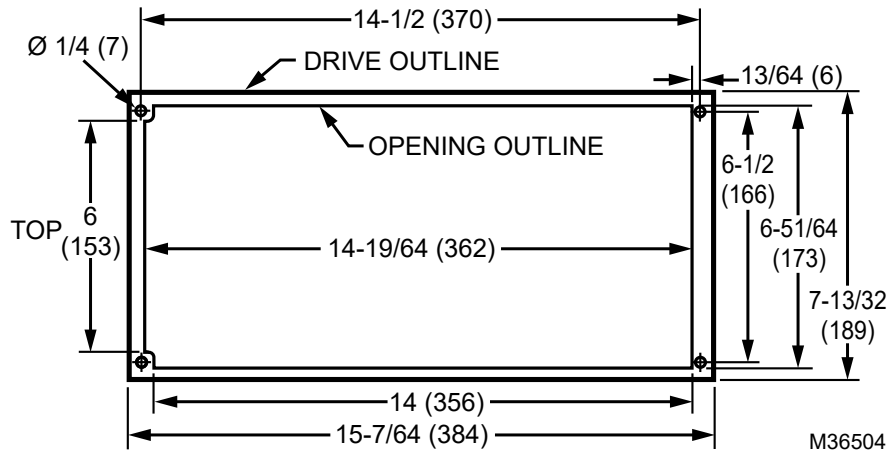

Fig. 8. Flange mounting cutout dimensions for MI4
[Unit: inches (mm)]

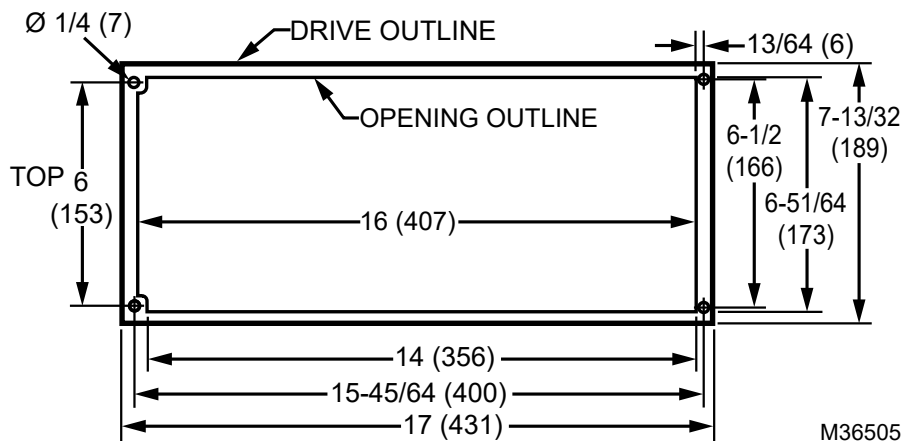

Fig. 9. Flange mounting cutout dimensions for MI5
[Unit: inches (mm)]

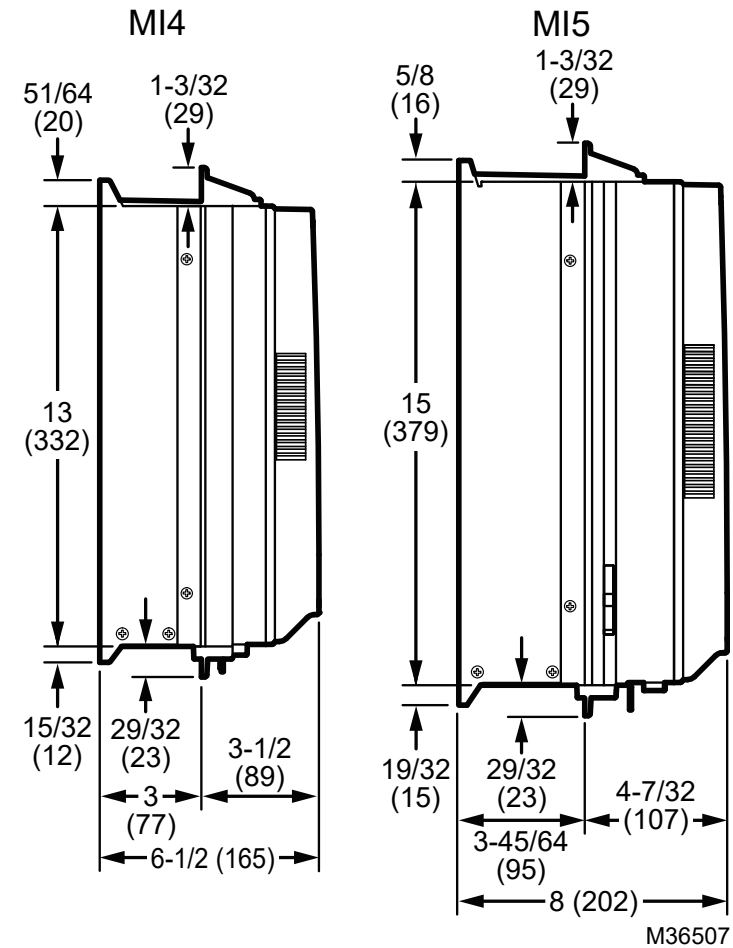

Fig. 10. Flange mounting depth dimensions
for MI4 and MI5 [Unit: inches (mm)]

3.2 HVAC232/402 dimensions

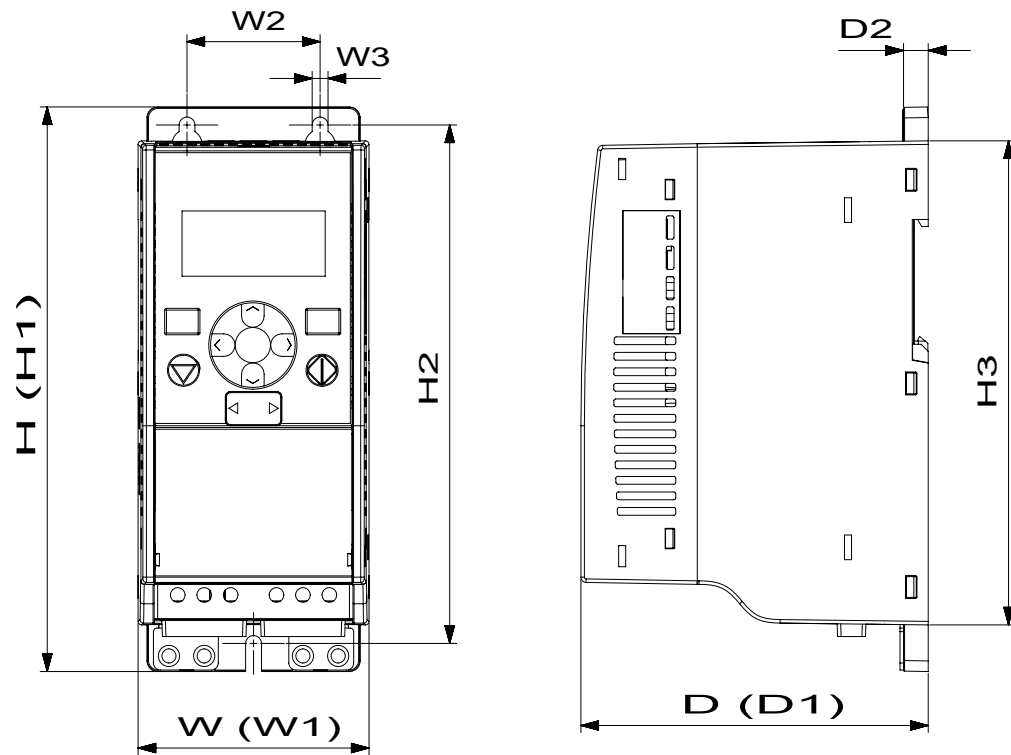

Fig. 11. HVAC232/402 dimensions, MI1 - MI3

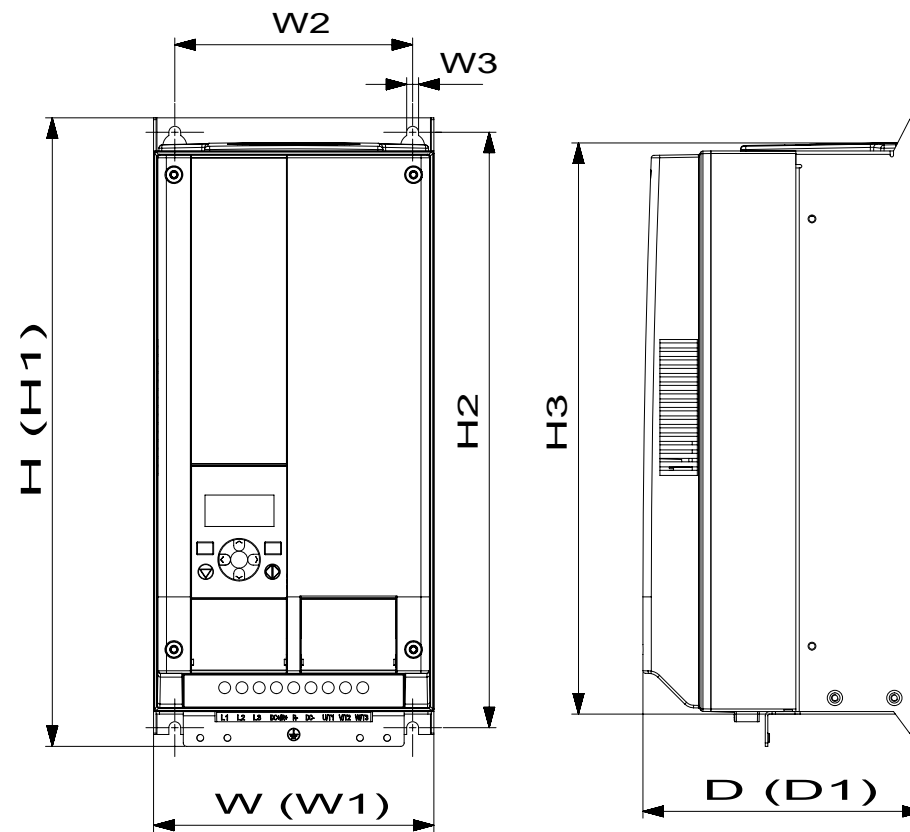

Fig. 12. HVAC232/402 dimensions, MI4 - MI5

Table 2. HVAC232/402 dimensions in inches (mm).

Type	H1	H2	H3	W1	W2	W3	D1	D2
MI1	6.3 (160.1)	5.8 (147)	5.4 (137.3)	2.6 (65.5)	1.5 (37.8)	.18 (4.5)	3.9 (98.5)	.28 (7)
MI2	7.7 (195)	7.2 (183)	6.7 (170)	3.5 (90)	2.5 (62.5)	.22(5.5)	4 (101.5)	.28 (7)
MI3	10 (254.3)	9.6 (244)	9.0 (229.3)	3.9 (100)	3.0 (75)	.22 (5.5)	4.3 (108.5)	.28 (7)
MI4	14.6 (370)	13.8 (350.5)	13.2 (336.5)	6.5 (165)	5.5 (140)	.28 (7)	6.5 (165)	-
MI5	16.3 (414)	15.7 (398)	15.1 (383)	6.5 (165)	5.5 (140)	.28 (7)	8.0 (202)	-

Table 3. HVAC232/402 frame dimensions (mm) and weights in lbs (kg)

Frame	Dimensions in inches (mm)			Weight in lbs (kg.)*
	W	H	D	
MI1	2.6 (66)	6.3 (160)	3.9 (98)	1.1 (0.5)
MI2	3.5 (90)	7.7 (195)	4 (102)	1.6 (0.7)
MI3	3.9 (100)	10 (254.3)	4.3 (109)	2.2 (1)
MI4	6.5 (165)	14.6 (370)	6.5 (165)	17.7 (8)
MI5	6.5 (165)	16.3 (414)	8 (202)	22 (10)

* without shipping package

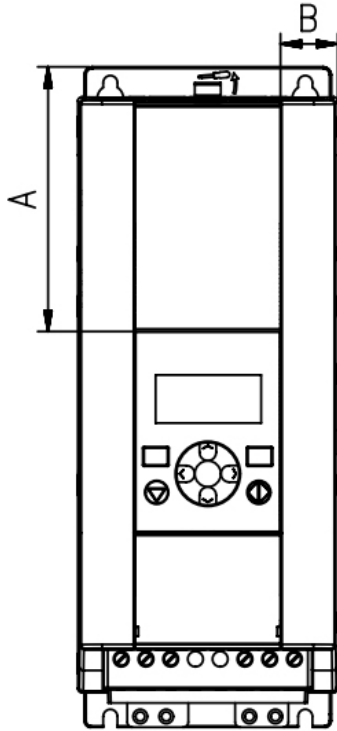

Fig. 13. HVAC232/402 dimensions,
MI2-3 - Display Location

Dimensions in inches (mm)	Frame	
	MI2	MI3
A	.7 (17)	.9 (22.3)
B	1.7 (44)	4 (102)

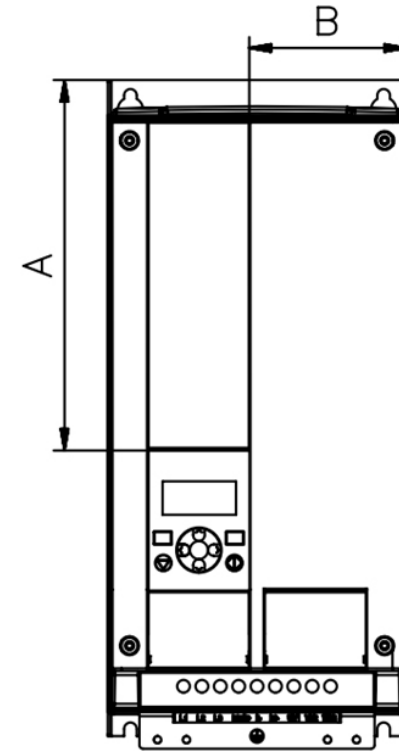

Fig. 14. HVAC232/402 dimensions,
MI4-5 - Display Location

Dimensions in inches (mm)	Frame	
	MI2	MI3
A	8 (205)	9.8 (248.5)
B	3.4 (87)	3.4 (87)

3.3 Cooling

Enough free space shall be left above and below the frequency converter to ensure sufficient air circulation and cooling. You will find the required dimensions for free space in the table below.

If several units are mounted above each other, the required free space equals C + D (see figure below). Moreover, the outlet air used for cooling by the lower unit must be directed away from the air intake of the upper unit.

The amount of cooling air required is indicated below. Also make sure that the temperature of the cooling air does not exceed the maximum ambient temperature of the converter.

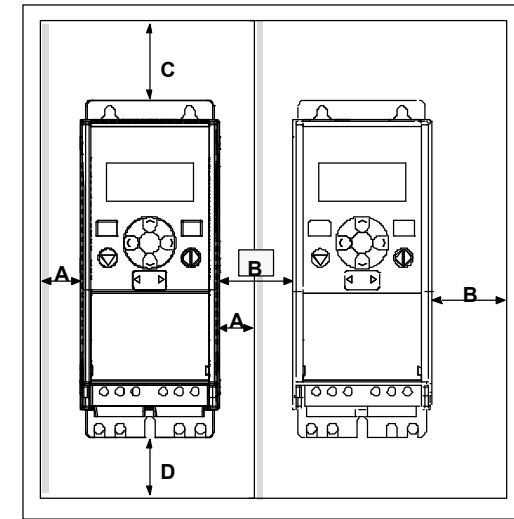

Fig. 15. Installation space

Table 4. Min. clearances around AC drive

Type	Min clearance in inches (mm)			
	A*	B*	C	D
MI1	.8 (20)	.8 (20)	3.9 (100)	2 (50)
MI2	.8 (20)	.8 (20)	3.9 (100)	2 (50)
MI3	.8 (20)	.8 (20)	3.9 (100)	2 (50)
MI4	.8 (20)	.8 (20)	3.9 (100)	3.9 (100)
MI5	.8 (20)	.8 (20)	4.7 (120)	3.9 (100)

* Min clearance A and B for drives for MI1~MI3 can be 0 inches if the ambient temperature is below 104 °F (40°C).

- A = clearance around the freq. converter (see also B)
- B = distance from one frequency converter to another or distance to cabinet wall
- C = free space above the frequency converter
- D = free space underneath the frequency converter

i

NOTE:
See the mounting dimensions on the back of the drive.

Leave free space for cooling above (100 mm), below (50 mm), and on the sides (20 mm) of HVAC232/402! (For MI1 - MI3, side-to-side installation allowed only if the ambient temperature is below 104 °F (40 °C); For MI4-MI5, side-to-side installation is not allowed.

Table 5. Required cooling air

Type	Cooling air required in cfm (m ³ /h)
MI1	5.886 (10)
MI2	5.886 (10)
MI3	17.658 (30)
MI4	26.487 (45)
MI5	44.145 (75)

3.4 Power losses

If the operator wants to raise the switching frequency of the drive for some reason (typically e.g. in order to reduce the motor noise), this inevitably affects the power losses and cooling requirements, for different motor shaft power, operator can select the switching frequency according to the graphs below.

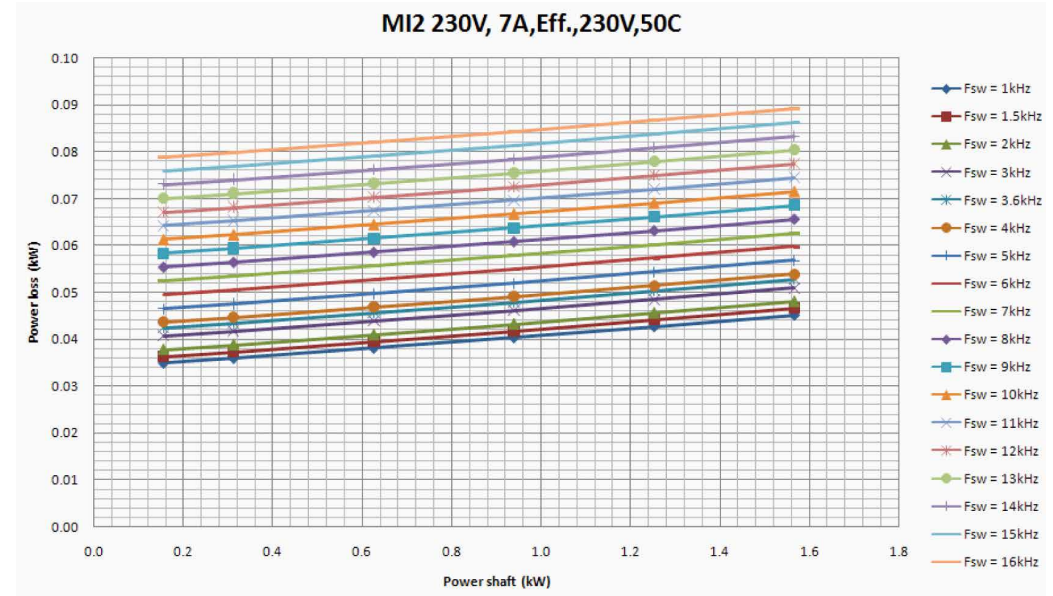

MI1 - MI3 1P 230 V POWER LOSS

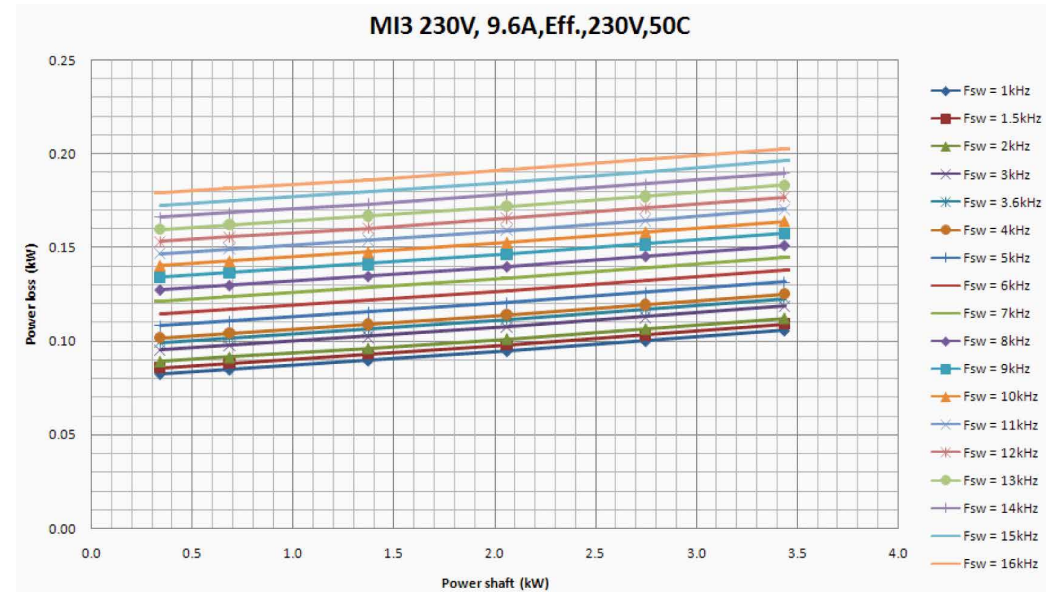
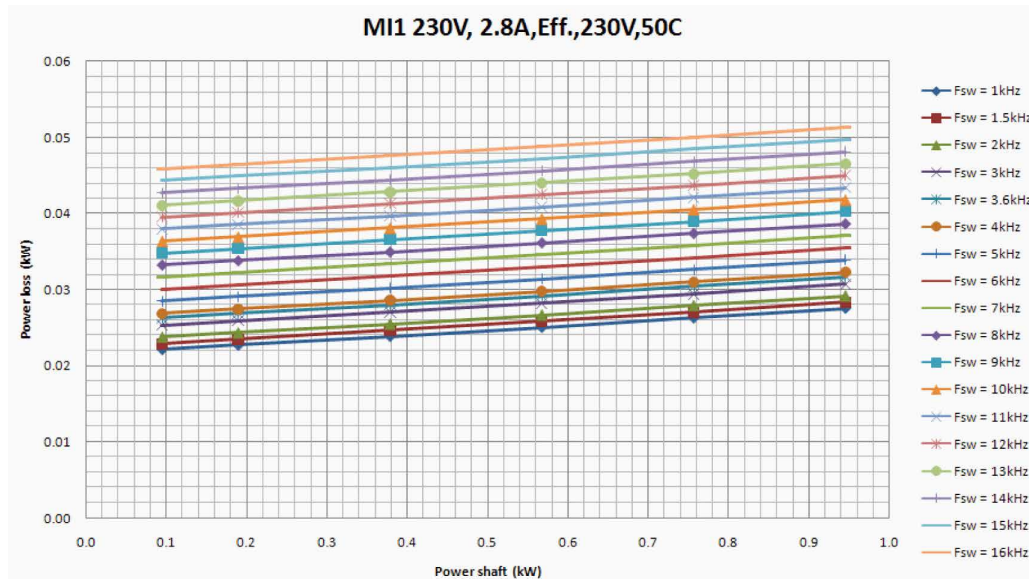

MI1 - MI5 3P 400 V POWER LOSS

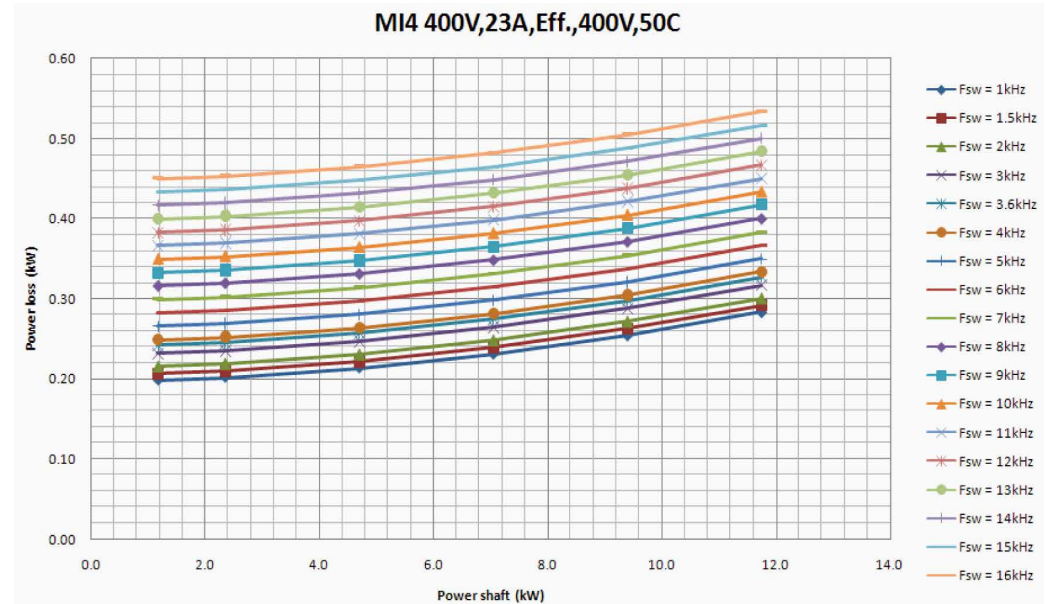
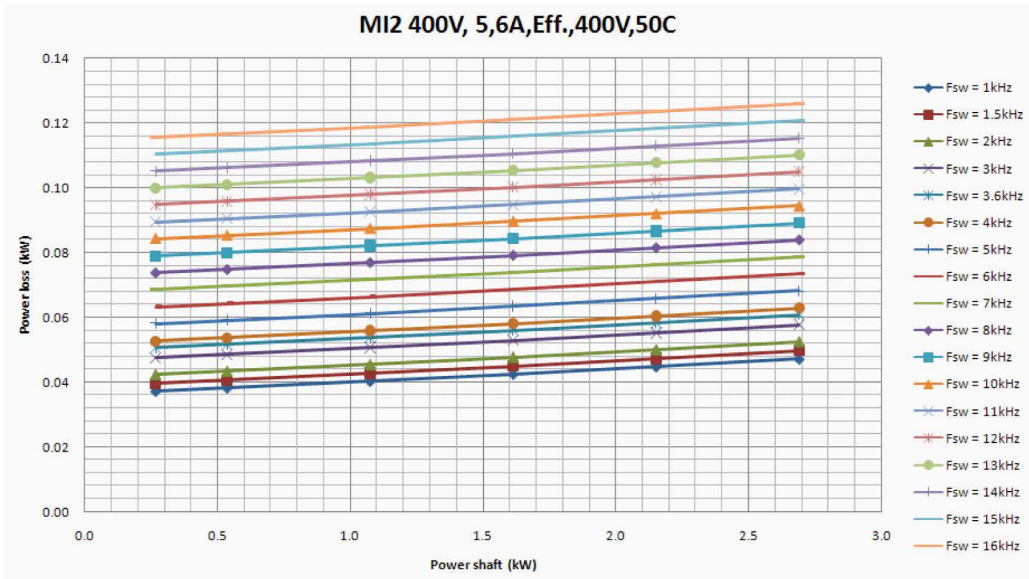
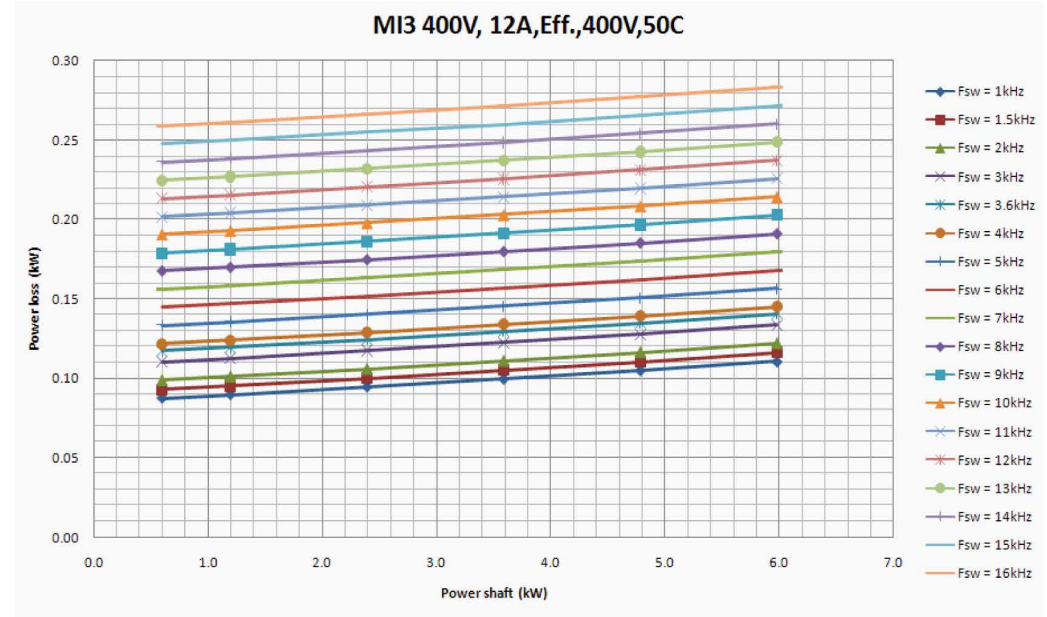
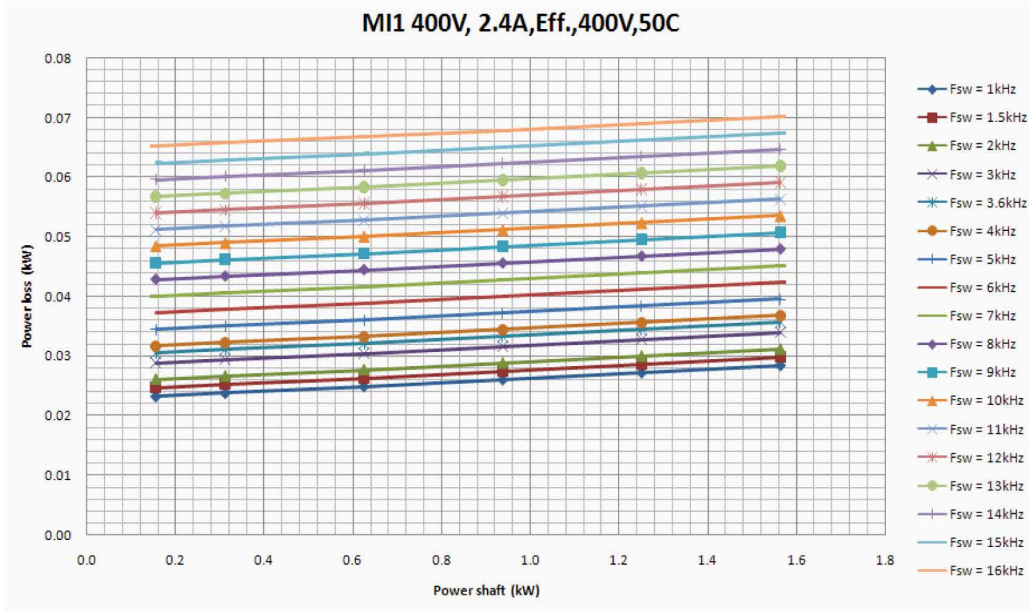

MI1 - MI5 3P 400 V POWER LOSS

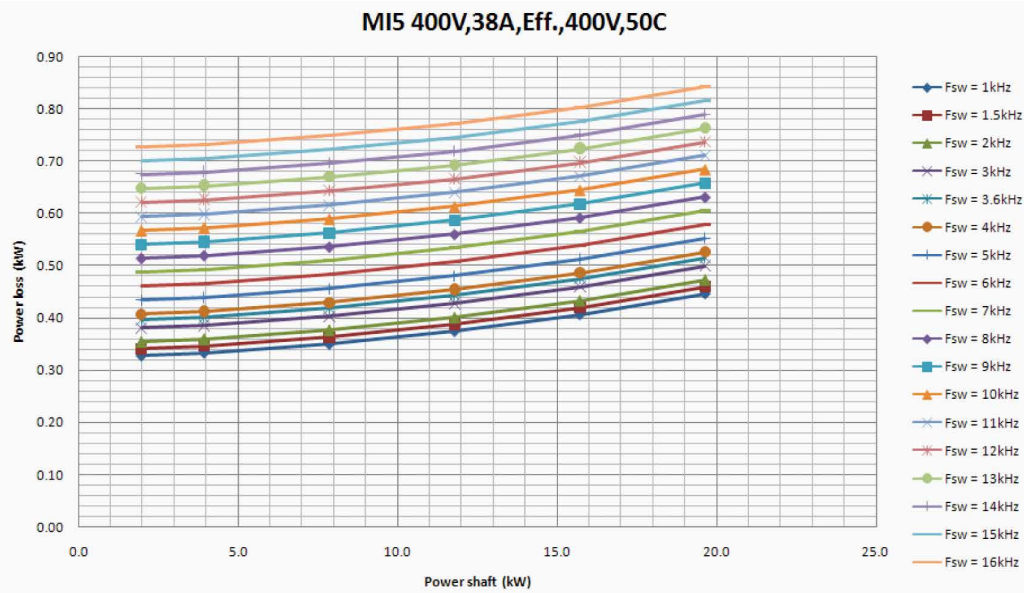

3.5 EMC levels

EN61800-3 defines the division of frequency converters into four classes according to the level of electromagnetic disturbances emitted, the requirements of a power system network and the installation environment (see below). The EMC class of each product is defined in the type designation code.

Category C1: Frequency converters of this class comply with the requirements of category C1 of the product standard EN 61800-3(2004). Category C1 ensures the best EMC characteristics and it includes converters the rated voltage of which is less than 1000 V and which are intended for use in the 1st environment.

	NOTE: The requirements of class C are fulfilled only as far as the conducted emissions are concerned.
--	---

Category C2: Frequency converters of this class comply with the requirements of category C2 of the product standard EN 61800-3(2004). Category C2 includes converters in fixed installations and the rated voltage of which is less than 1000 V. The class C2 frequency converters can be used both in the 1st and the 2nd environment.

Category C4: The drives of this class do not provide EMC emission protection. These kinds of drives are mounted in enclosures.

Environments in product standard EN 61800-3 (2004)

First environment: Environment that includes domestic premises. It also includes establishments directly connected without intermediate transformers to a low-voltage power supply network which supplies buildings used for domestic purposes.

	NOTE: Houses, apartments, commercial premises or offices in a residential building are examples of first environment locations.
---	---

Second environment: Environment that includes all establishments other than those directly connected to a low-voltage power supply network which supplies buildings used for domestic purposes.

	NOTE: Industrial areas, technical areas of any building fed from a dedicated transformer are examples of second environment locations.
---	--

3.6 Changing the EMC protection class from C2 to C4

The EMC protection class of MI1-3 frequency converters can be changed from class C2 to class C4 by **removing the EMC-capacitor disconnecting screw**, see figure below. MI4 & 5 can also be changed by removing the EMC jumpers.

	<p>NOTE: Do not attempt to change the EMC level back to class C2. Even if the procedure above is reversed, the frequency converter will no longer fulfil the EMC requirements of class C2!</p>
--	---

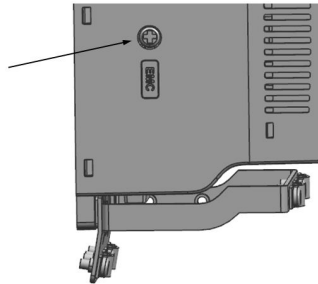

Fig. 16. EMC disconnecting screw, MI1 - MI3

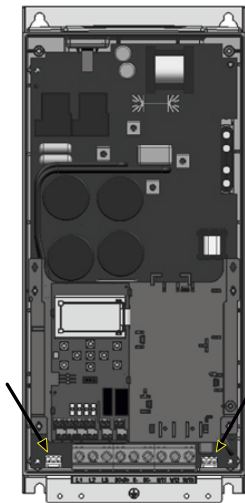

Fig. 17. EMC jumpers, MI4

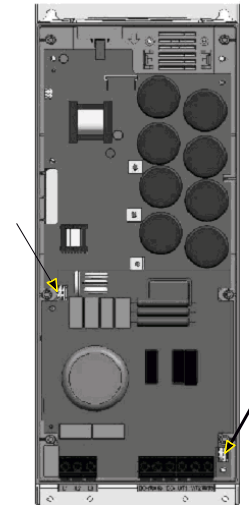

Fig. 18. EMC jumpers, MI5



Fig. 19. Jumpers

- Remove the main cover and locate the two jumpers.
- Disconnect the RFI-filters from ground by lifting the jumpers up from their default positions. See Figure 19.

3.7 Cabling and connections

Power cabling



NOTE:

Tightening torque for power cables is 0.5 - 0.6 Nm.

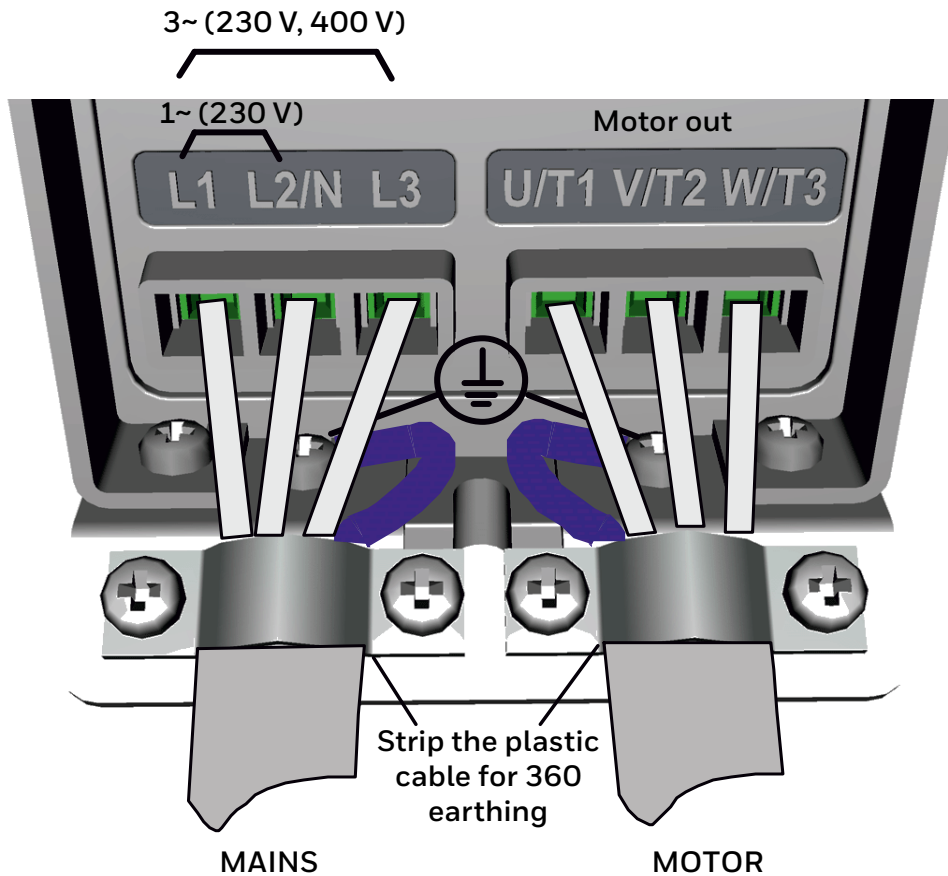

Fig. 20. HVAC232/402 power connections, MI1

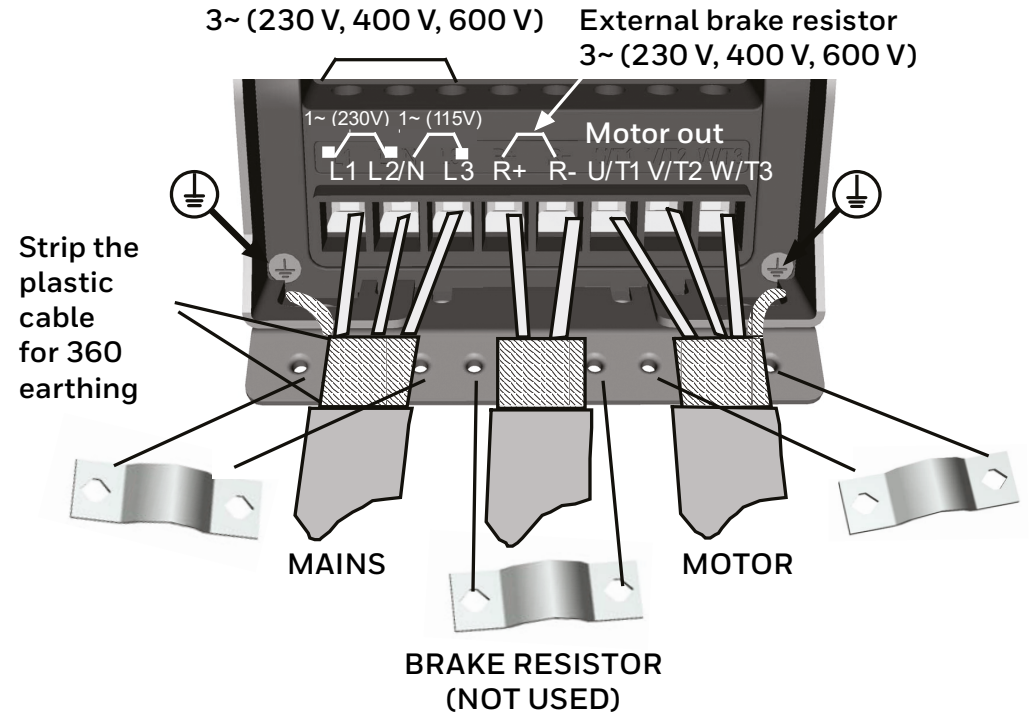

Fig. 21. HVAC232/402 power connections, MI2 - MI3

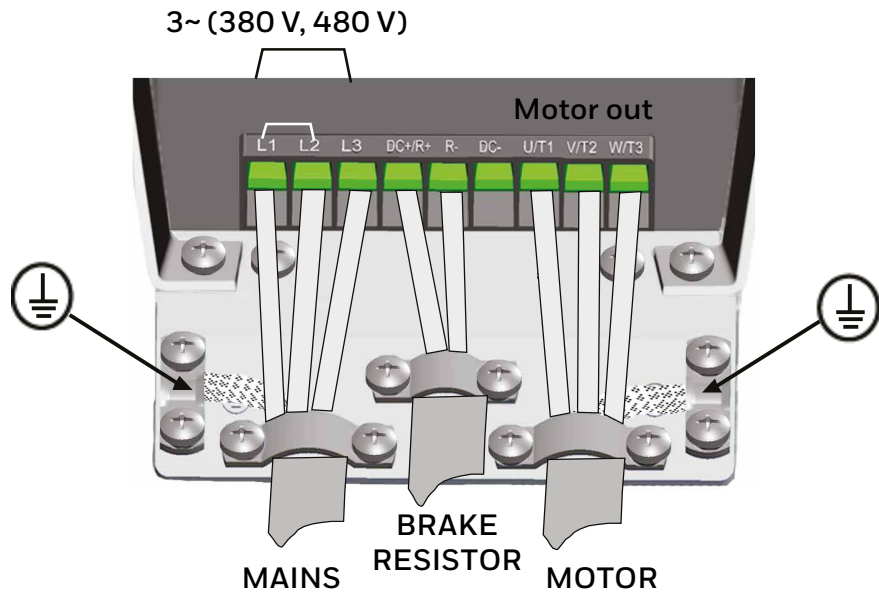

Fig. 22. HVAC232/402 power connections, MI4

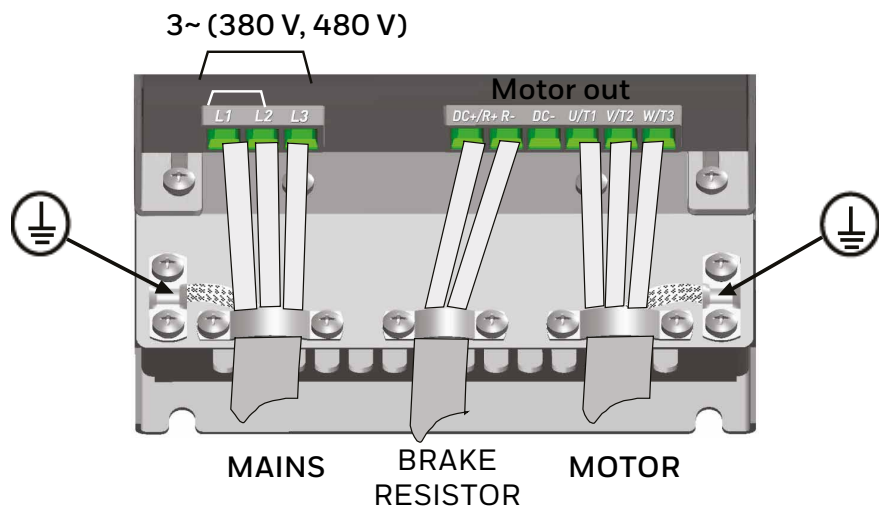

Fig. 23. HVAC232/402 power connections, MI5

Control Cabling

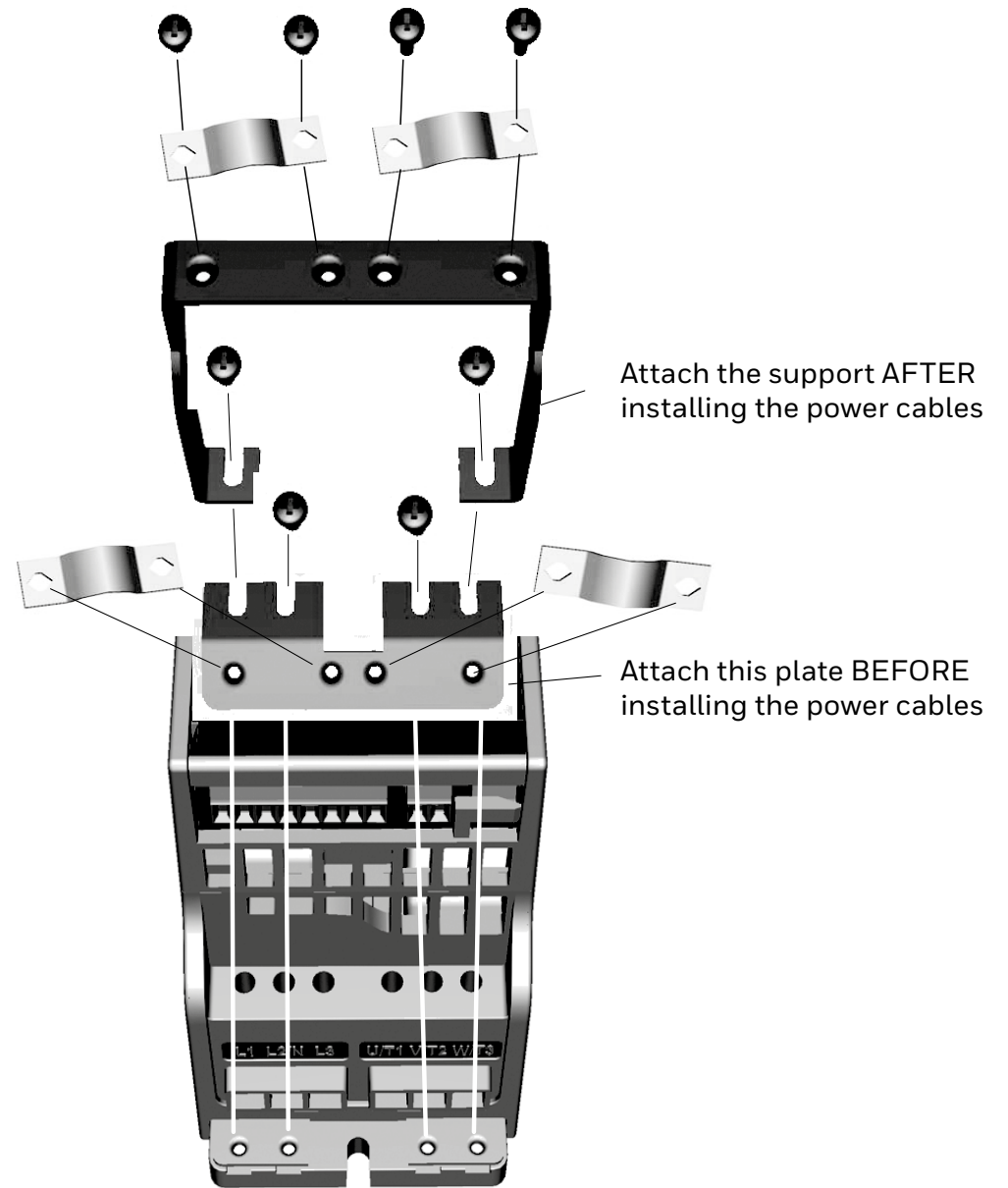

Fig. 24. Mount the PE-plate and API cable support, MI1 - MI3

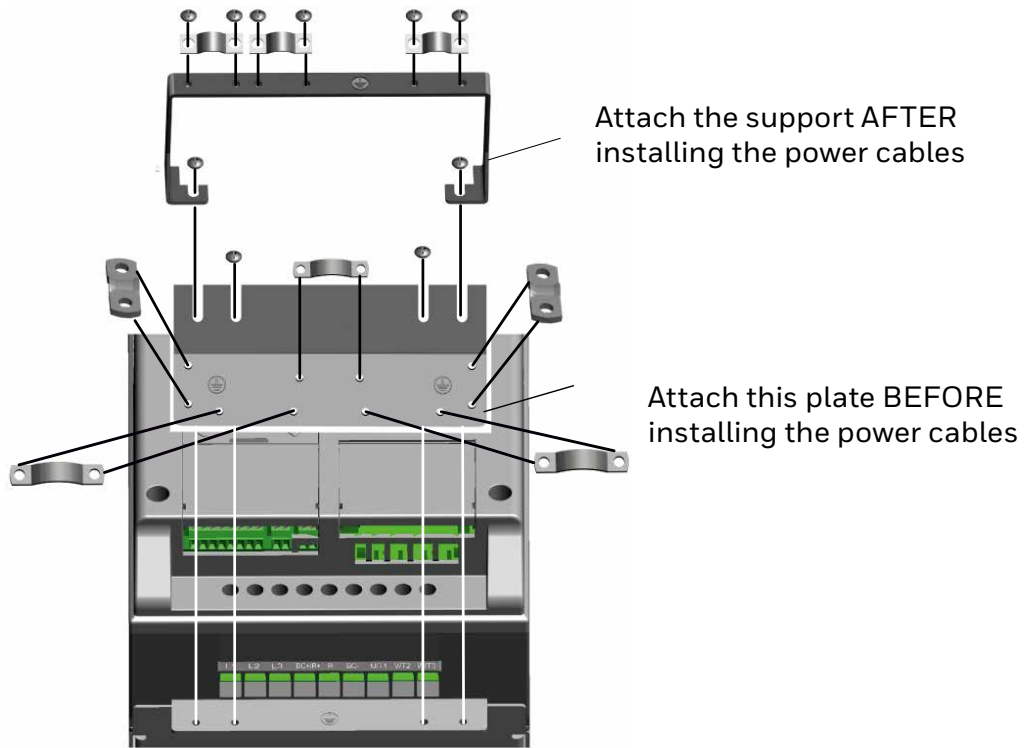

Fig. 25. Mount the PE-plate and API cable support, MI4 - MI5

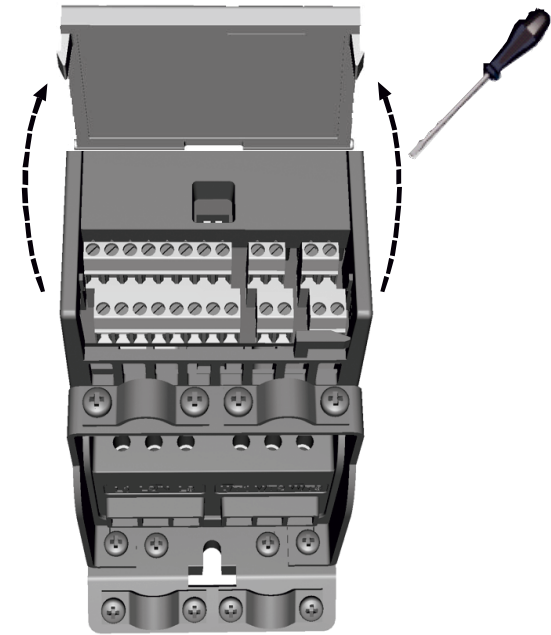

Fig. 26. Open the lid, MI1 - MI3

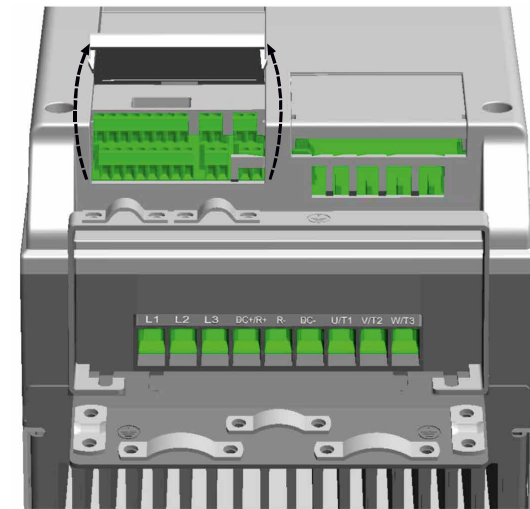

Fig. 27. Open the lid, MI4 - MI5

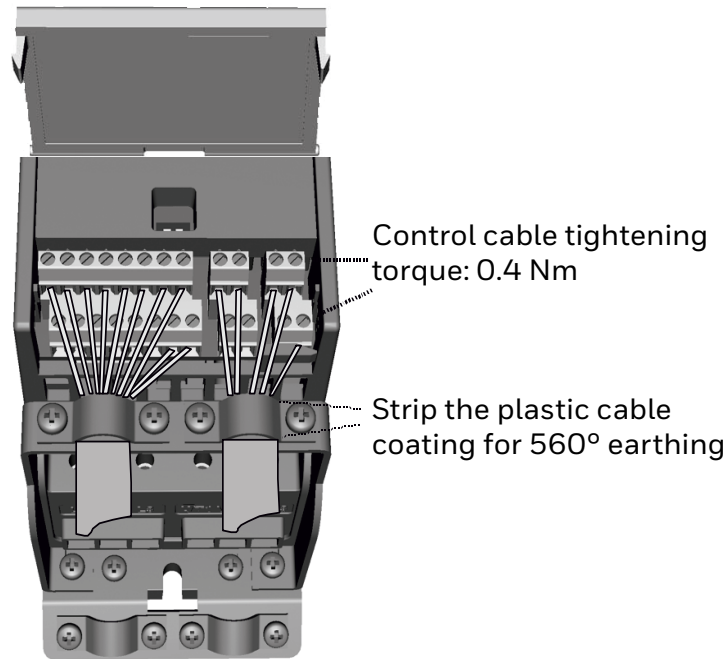

Fig.28. Install the control cables MI1-MI3.
See Chapter „6.2 Control I/O“ on page 42

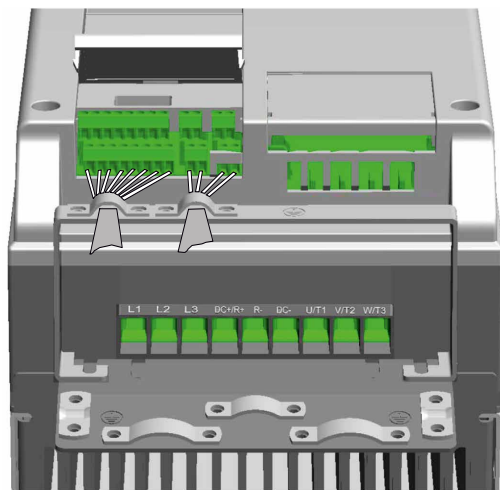

Fig. 29. Install the control cables MI4 - MI5.
See Chapter „6.2 Control I/O“ on page 42

Allowed option boards in HVAC232/402



NOTE:

When OPTB1, OPTB2 or OPTB4 are used in HVAC232/402, +24 VDC ($\pm 10\%$, min. 300 mA) power should be supplied to Terminal 6 (+24_out) and Terminal 3 (GND) in control board.

Table 6.

Option boards (all boards are varnished)	
OPTB1	6 × inputs/outputs programmable
OPTB2	2 × Relay output + Thermistor
OPTB4	2 AO & 1 AI mA
OPTB5	3 × Relay output
OPTB9	1 × RO, 5 × inputs 42...240 V
OPTBF	1 AI mA, 1RO, 1DO op. col.
OPTBH	3 × temp sensors Pt-1000, Ni-1000 or Pt-100
OPTE9	Modbus TCP Dual port

Optional board assembly structure:

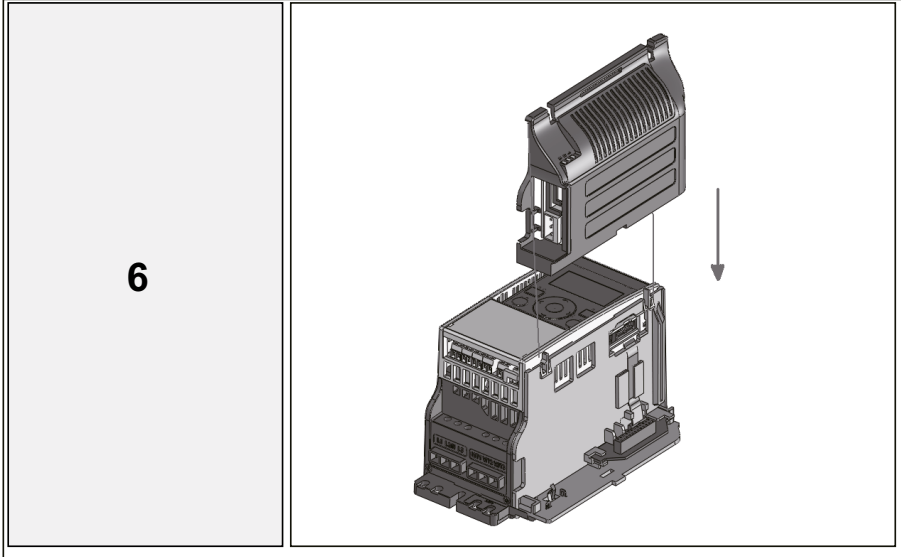
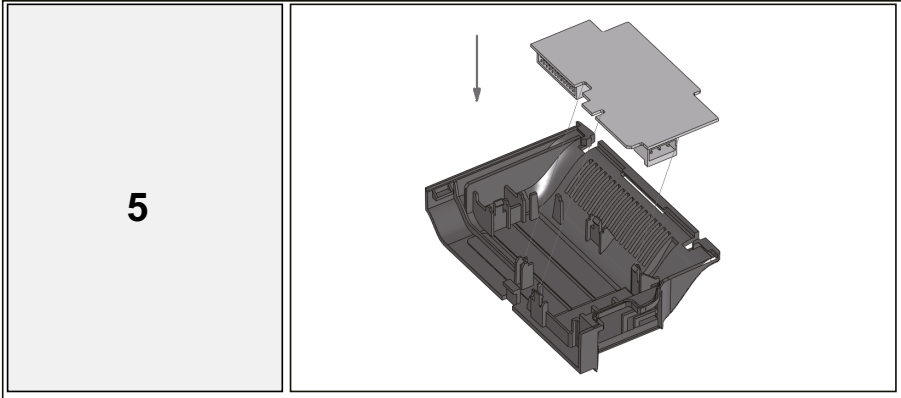
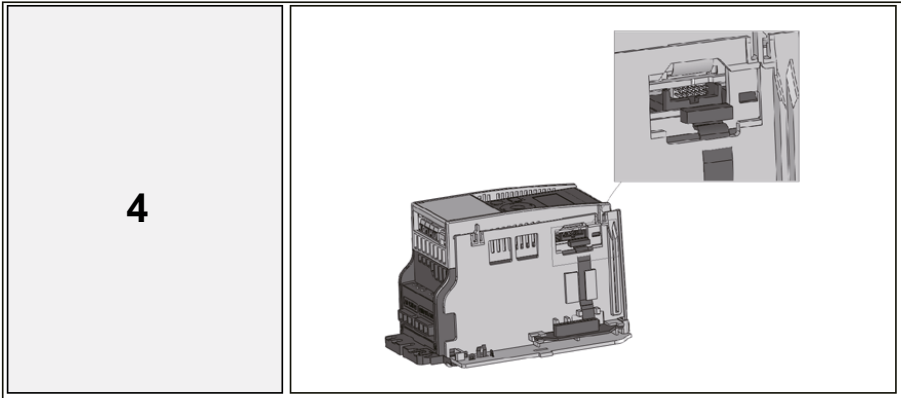
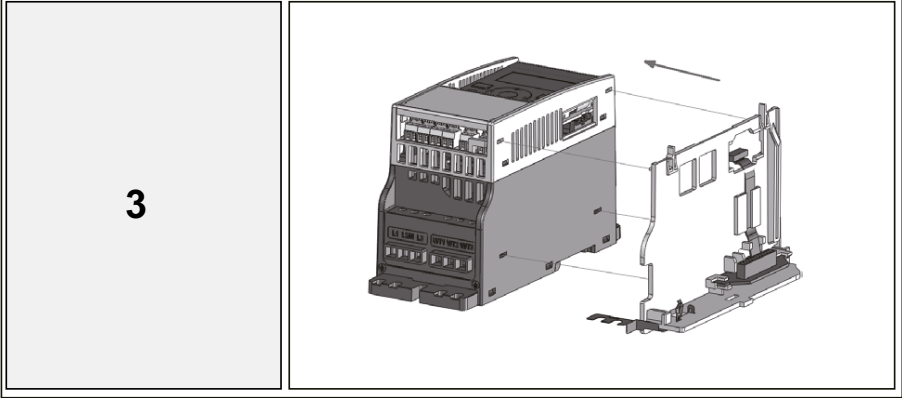
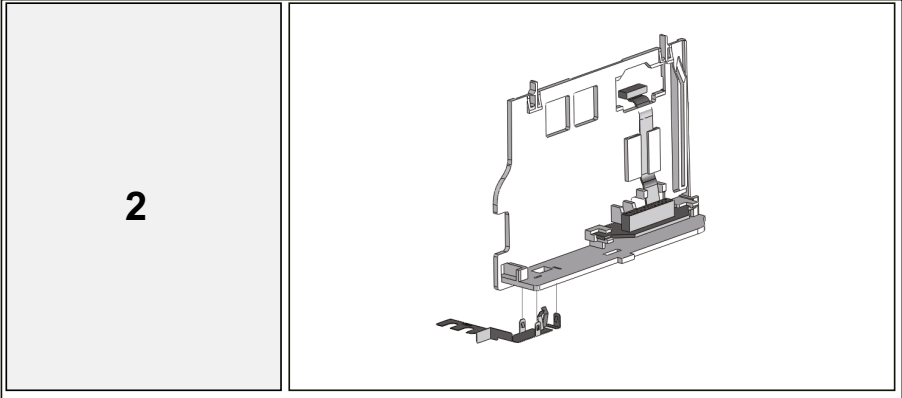
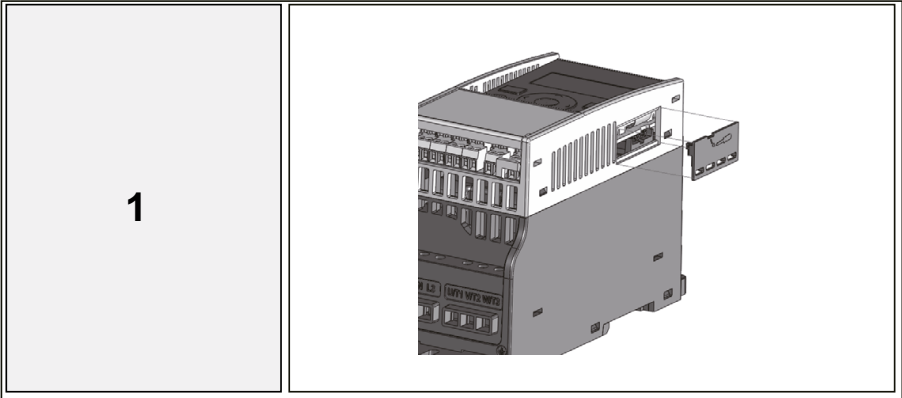

3.8 Screw of cables

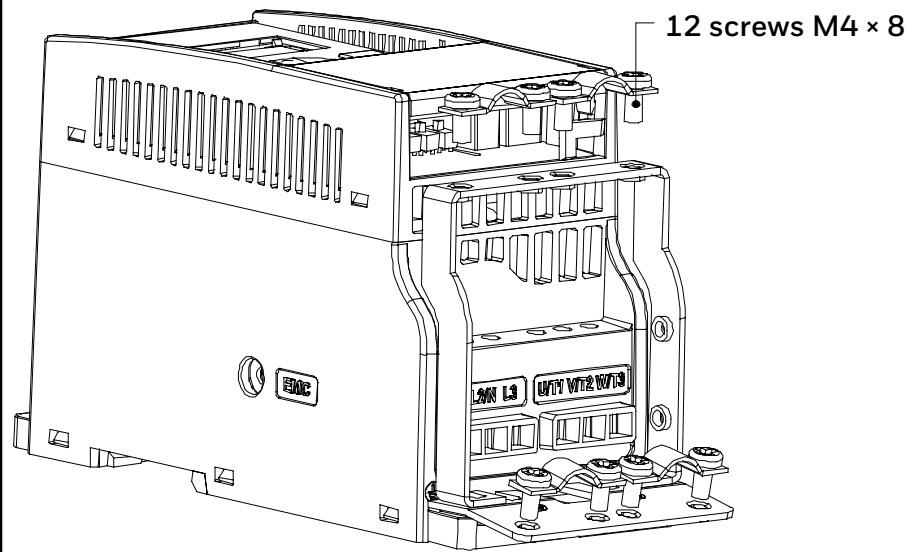

Fig. 30. MI1 screws

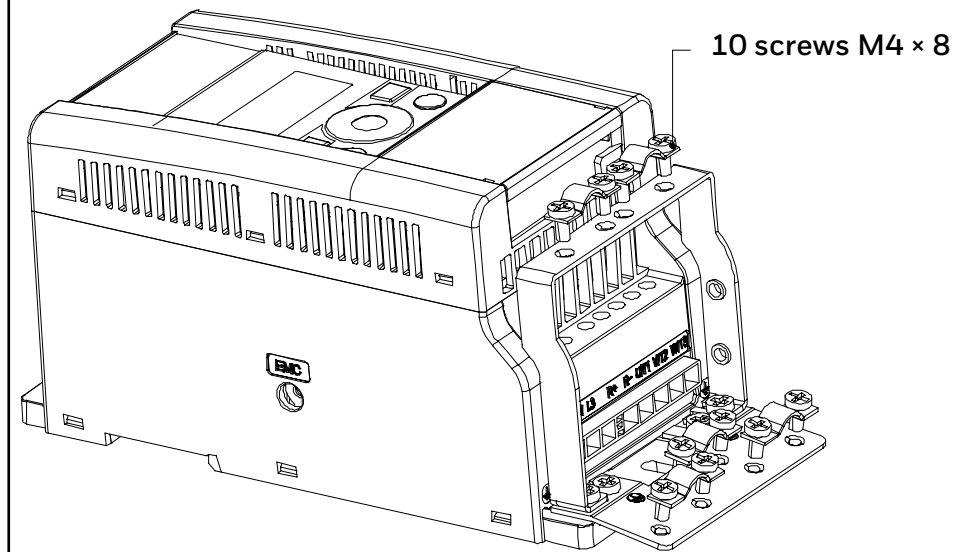

Fig. 31. MI2 screws

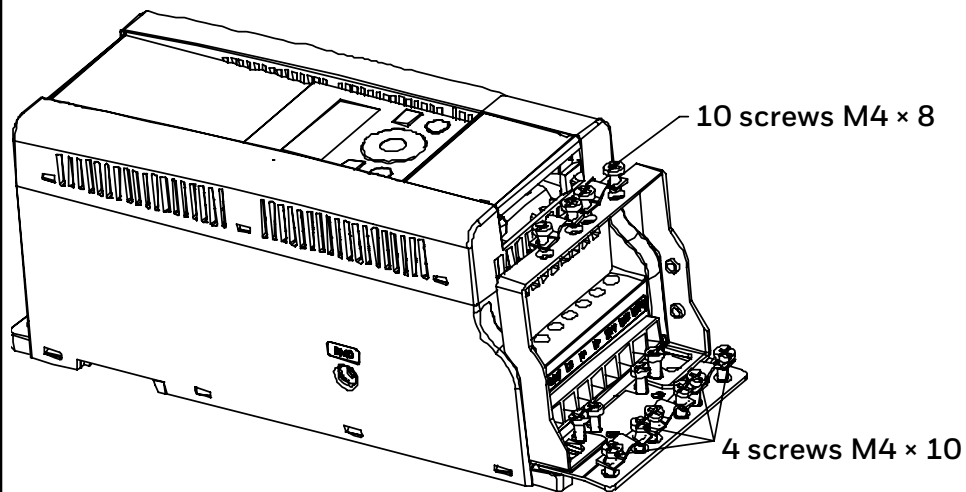

Fig. 32. MI3 screws

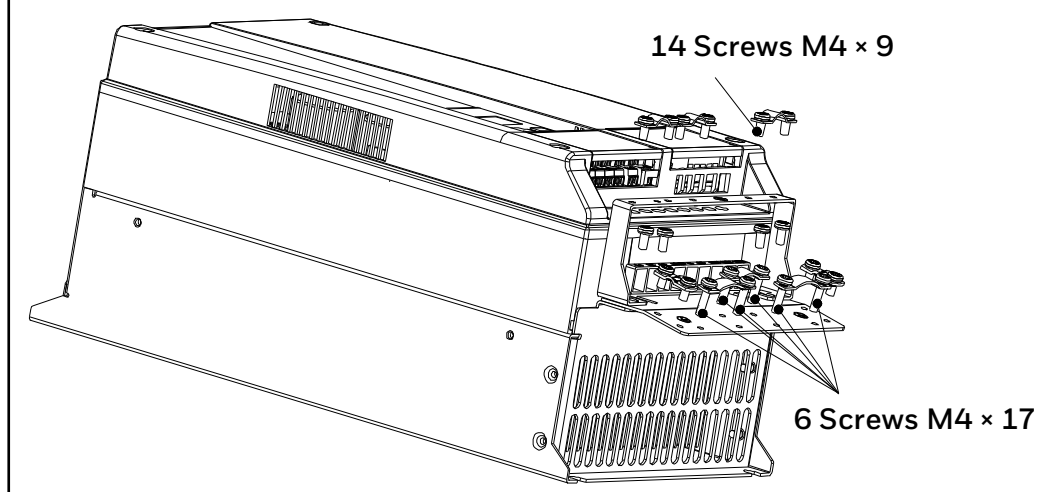

Fig. 33. MI4 - MI5 screws

Cable and fuse specifications

Use cables with heat resistance of at least 158 °F (70 °C). The cables and the fuses must be dimensioned according to the tables below.

Installation of cables is presented in chapter „3.10 Cable installation“ on page 32.

The fuses function also as cable overload protection. The recommended fuse types are gG/gL (IEC 60269-1). The fuse voltage rating should be selected according to the supply network. The final selection should be made according to local regulations, cable installation conditions and cable specification. Bigger fuses than what is recommended below should not be used.

Check that the fuse operating time is less than 0.4 seconds. Operating time depends on used fuse type and impedance of the supply circuit.

Consult the factory about faster fuses.

Honeywell offers recommendations also for aR (IEC 60269-4) and gS (IEC 60269-4) fuse ranges.

These instructions apply only to cases with one motor and one cable connection from the frequency converter to the motor. In any other case, ask the factory for more information.

**Table 7. Cable types required to meet standards.
EMC categories are described in Chapter „3.5 EMC levels“ on page 21.**

EMC category	cat. C2	cat. C4
Mains cable types	1	1
Motor cable types	3	1
Control cable types	4	4

Table 8. Cable type descriptions

Cable type	Description
1	Power cable intended for fixed installation and the specific mains voltage. Shielded cable not required. (NKCABLES / MCMK or similar recommended)
2	Power cable equipped with concentric protection wire and intended for the specific mains voltage. (NKCABLES / MCMK or similar recommended).
3	Power cable equipped with compact low-impedance shield and intended for the specific mains voltage. (NKCABLES / MCCMK, SAB / ÖZCUY-J or similar recommended). *360° earthing of both motor and FC connection required to meet the standard
4	Screened cable equipped with compact low-impedance shield (NKCABLES /Jamak, SAB / ÖZCuY-O or similar).

Table 9. Cable and fuse sizes for HVAC232/402, 208 - 240 V, 1~

Frame	Power [kW]	Fuse [A]	Mains cable Cu [mm ²]	Motor cable Cu [mm ²]	Terminal cable size (min/max)			
					Main terminal [mm ²]	Earth terminal [mm ²]	Control terminal [mm ²]	Relay terminal [mm ²]
MI1	0.25...0.55	10	2×1.5+1.5	3×1.5+1.5	1.5...4	1.5...4	0.5...1.5	0.5...1.5
MI2	0.75...1.50	20	2×2.5+2.5	3×1.5+1.5	1.5...4	1.5...4	0.5...1.5	0.5...1.5
MI3	2.2*	32	2×6+6	3×1.5+1.5	1.5...6	1.5...6	0.5...1.5	0.5...1.5

* The maximum ambient operating temperature of this drive is 40 °C!

Table 10. Cable and fuse sizes for HVAC232/402, 380 - 480 V, 3~

Frame	Power [kW]	Fuse [A]	Mains cable Cu [mm ²]	Motor cable Cu [mm ²]	Terminal cable size (min/max)			
					Main terminal [mm ²]	Earth terminal [mm ²]	Control terminal [mm ²]	Relay terminal [mm ²]
MI1	0.37...0.75	6	3×1.5+1.5	3×1.5+1.5	1.5...4	1.5...4	0.5...1.5	0.5...1.5
MI2	1.1...2.2	10	3×1.5+1.5	3×1.5+1.5	1.5...4	1.5...4	0.5...1.5	0.5...1.5
MI3	3.0...5.5	20	3×2.5+2.5	3×2.5+2.5	1.5...6	1.5...6	0.5...1.5	0.5...1.5
MI4	7.5...25.5	20	3×6+6	3×6+6	1...10Cu	1...10	0.5...1.5	0.5...1.5
MI5	15...18.5	40	3×10+10	3×10+10	2.5...50 Cu/Al	2.5...35	0.5...1.5	0.5...1.5



NOTE:

To fulfil standard EN61800-5-1, the protective conductor should be at least 10 mm² Cu or 16 mm² Al. Another possibility is to use an additional protective conductor of at least the same size as the original one.

General cabling rules

1	Before starting the installation, check that none of the components of the frequency converter is live.
2	<p>Place the motor cables sufficiently far from other cables:</p> <ul style="list-style-type: none"> • Avoid placing the motor cables in long parallel lines with other cables. • If the motor cable runs in parallel with other cables, the minimum distance between the motor cable and other cables is 1 ft. (0.3 m) • The given distance also applies between the motor cables and signal cables of other systems. • The maximum length of the motor cables for MI1-3 is 98 ft. (30 m). For MI4 & 5, maximum length is 164 ft. (50 m), if use longer cable, current accuracy will be decreased. • The motor cables should cross other cables at an angle of 90 degrees.
3	If cable insulation checks are needed, see Chapter „3.11 Cable and motor insulation checks“ on page 32.
4	<p>Connecting the cables:</p> <ul style="list-style-type: none"> • Strip the motor and mains cables as advised in Figure „Fig. 34. Stripping of cables“ on page 31. • Connect the mains, motor and control cables into their respective terminals, see Figures 3.16 to 3.29 and see Chapter „6.2 Control I/O“ on page 42. • Note the tightening torques of power cables and control cables given in Chapter „Power cabling“ on page 23 and „Control Cabling“ on page 24. • For information on cable installation see Chapter „3.10 Cable installation“ on page 32. • Make sure that the control cable wires do not come in contact with the electronic components of the unit. • Check the connection of the earth cable to the motor and the frequency converter terminals marked with ⚡. • Connect the separate shield of the motor cable to the earth plate of the frequency converter, motor and the supply centre.

3.9 Stripping lengths of motor and mains cables

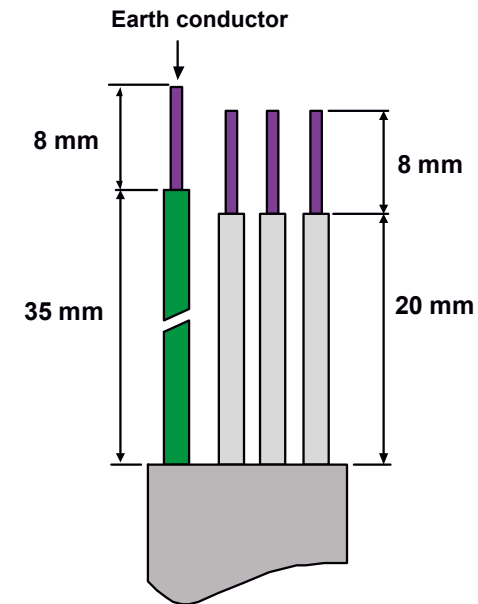

Fig. 34. Stripping of cables



NOTE:

Strip also the plastic cover of the cables for 360 degree earthing. See Figures „Fig. 20. HVAC232/402 power connections, MI1“ on page 23, „Fig. 21. HVAC232/402 power connections, MI2 - MI3“ on page 23 and „Fig. 24. Mount the PE-plate and API cable support, MI1 - MI3“ on page 24. See Chapter „6.2 Control I/O“ on page 42.

3.10 Cable installation

The units are suitable for use on a circuit capable of delivering not more than 50,000 ARMS symmetrical amperes.

Motor overload protection provided at 110% of full load current.

3.11 Cable and motor insulation checks

These checks can be performed as follows if motor or cable insulations are suspected to be faulty.

1. Motor cable insulation checks

Disconnect the motor cable from terminals U/T1, V/T2 and W/T3 of the frequency converter and from the motor. Measure the insulation resistance of the motor cable between each phase conductor as well as between each phase conductor and the protective ground conductor.

The insulation resistance must be >1 MOhm.

2. Mains cable insulation checks

Disconnect the mains cable from terminals L1, L2 / N and L3 of the frequency converter and from the mains. Measure the insulation resistance of the mains cable between each phase conductor as well as between each phase conductor and the protective ground conductor.

The insulation resistance must be >1 MOhm.

3. Motor insulation checks

Disconnect the motor cable from the motor and open the bridging connections in the motor connection box. Measure the insulation resistance of each motor winding. The measurement voltage must equal at least the motor nominal voltage but not exceed 1000 V.

The insulation resistance must be >1 MOhm.

4 COMMISSIONING AND START-UP WIZARD

Before commissioning, read the warnings and instructions listed in „1 SAFETY“ on page 6!

4.1 Commissioning steps of HVAC232/402

1	Read carefully the safety instructions in „1 SAFETY“ on page 6 and follow them.
2	After the installation, make sure that: <ul style="list-style-type: none"> • both the frequency converter and the motor are grounded • the mains and motor cables comply with the requirements given in „Cable and fuse specifications“ on page 29 • the control cables are located as far as possible from the power cables (see „General cabling rules“ on page 31, step 2) and • the shields of the shielded cables are connected to protective earth. 
3	Check the quality and quantity of cooling air („3.3 Cooling“ on page 17).
4	Check that all Start / Stop switches connected to the I/O terminals are in Stop position.
5	Connect the frequency converter to mains.
6	Set the parameters of group 1 according to the requirements of your application. At least the following parameters should be set: <ul style="list-style-type: none"> • motor nominal speed, parameter 1.3 (“9.1 Quick setup parameters (Virtual menu, shows when par. 16.2 1)” on page 56) • motor nominal current, parameter 1.4 (“9.1 Quick setup parameters (Virtual menu, shows when par. 16.2 1)” on page 56) • application type („Active fire mode parameter group“ on page 131) <p>You will find the values needed for the parameters on the motor</p>

7	<p>Perform test run without motor. Perform either Test A or Test B:</p> <p>A) Control from the I/O terminals:</p> <ul style="list-style-type: none"> • Turn the Start/Stop switch to ON position. • Change the frequency reference (potentiometer). • Check the Monitoring Menu and make sure that the value of Output frequency changes according to the change of frequency reference. • Turn the Start / Stop switch to OFF position. <p>B) Control from the keypad:</p> <ul style="list-style-type: none"> • Select the keypad as the control place with par 2.1. You can also move to keypad control by pressing Loc/Rem button or select Local control with par 2.5. • Push the Start button on the keypad. • Check the Monitoring Menu and make sure that the value of Output frequency. changes according to the change of frequency reference. • Push the Stop button on
8	<p>Run the no-load tests without the motor being connected to the process, if possible. If this is impossible, secure the safety of each test prior to running it. Inform your coworkers of the tests.</p> <ul style="list-style-type: none"> • Switch off the supply voltage and wait up until the drive has stopped. • Connect the motor cable to the motor and to the motor cable terminals of the frequency converter. • See to that all Start / Stop switches are in Stop positions. • Switch the mains ON. • Repeat test 7A or 7B.
9	<p>Perform an identification run (see „Motor identification“ on page 98), especially if the application requires a high startup torque or a high torque with low speed.</p>
10	<p>Connect the motor to the process (if the noload test was running without the motor being connected).</p> <ul style="list-style-type: none"> • Before running the tests, make sure that this can be done safely. • Inform your co-workers of the tests. • Repeat test 7A or 7B.

4.2 Startup Wizard

Honeywell HVAC232/402 runs the startup wizard at initial power-up and whenever the drive is reset to factory defaults.

The Start-up wizard content is shown below. It always asks the basic parameters (P1.1-P16.1). If you activate the fire mode parameters with P16.1, it will go through rest of the Fire mode parameters.

Start-Up Wizard Parameter Group

P1.1 Motor Nominal Voltage

P1.2 Motor Nominal Frequency

P1.3 Motor Nominal Speed

P1.4 Motor Nominal Current

P1.5 Motor Cos phi (Power Factor)

P1.7 Current Limit

P1.23 Energy Optimization

P3.1 Min. Frequency

P3.2 Max. Frequency

P16.1 Active Fire Mode Parameter Group

P18.1 Fire Mode Password

P18.2 Fire Mode Frequency Select

P18.3 Fire Mode Frequency Preset

P18.4 Fire Mode Activation Close

P18.5 Fire Mode Activation Open

P18.6 Fire Mode Reverse

5 FAULT TRACING

When a fatal fault is detected by the frequency converter control electronics, the drive will stop and the symbol FT and the fault code blinked on the display are in the following format, e.g.:

FT 2
 └─ Fault code (02 = overvoltage)

The active fault can be reset by pressing BACK/RESET button when the API is in active fault menu level (FT XX), or pressing BACK/RESET button with long time (> 2 s) when the API is in active fault submenu level (F5.x), or via the I/O terminal or field bus. Reset fault history (long push > 5 s), when the API is in fault history submenu level (F6.x). The faults with subcode and time labels are stored in the Fault history submenu which can be browsed. The different fault codes, their causes and correcting actions are presented in the table below.

Table 11. Fault codes

Fault code	Fault name	Possible cause	Correcting actions
1	Overcurrent	Frequency converter has detected too high a current (>4*IN) in the motor cable: <ul style="list-style-type: none"> • sudden heavy load increase • short circuit in motor cables • unsuitable motor 	Check loading. Check cables. Check motor size.
2	Overvoltage	The DC-link voltage has exceeded the internal safety limit: <ul style="list-style-type: none"> • deceleration time is too short • high overvoltage peaks in mains 	Increase the deceleration time („Deceleration time 1“ on page 33 or „Table 25. Ramps and brakes setup.“ on page 33).
3	Earth fault	Current measurement has detected extra leakage current at start: <ul style="list-style-type: none"> • insulation failure in cables or motor 	Check motor cables and motor
8	System fault	<ul style="list-style-type: none"> • component failure • faulty operation 	Reset the fault and restart. If the fault re-occurs, contact the distributor near to you. NOTE! If fault F8 occurs, find out the subcode of the fault from the Fault History menu under Id xxx

Fault code	Fault name	Possible cause	Correcting actions
9	Under voltage	The DC-link voltage has gone below the internal safety limit: <ul style="list-style-type: none"> • most probable cause: supply voltage is too low • frequency converter internal fault • power outages 	In case of temporary supply voltage break reset the fault and restart the frequency converter. Check the supply voltage. If it is adequate, an internal failure has occurred. Contact the distributor near to you.
10	Input phase fault	Input phase is missing	Check supply voltage, fuses and cable.
11	Output phase fault	Current measurement has detected that there is no current in one motor phase.	Check motor cable and motor.
13	Frequency converter under temperature	Heat sink temperature is under 14 °F (-10 °C)	Check the ambient temperature.
14	Frequency converter over temperature	Heat sink is overheated.	Check that the cooling air flow is not blocked. Check the ambient temperature. Clean the heatsink dust. Make sure that the switching frequency is not too high in relation to ambient temperature and motor load.
15	Motor stalled	Motor stall protection has tripped.	Check that the motor is able to rotate freely.
16	Motor over temperature	Motor overheating has been detected by frequency converter motor temperature model. Motor is overloaded.	Decrease the motor load. If no motor overload exists, check the temperature model parameters.
17	Motor underload	Motor underload protection has tripped.	Check motor and load, , as well as the low load detection parameters (P11.14 - P11.16). E.g. for broken belts or dry pumps.
22	EEPROM checksum fault	Parameter save fault <ul style="list-style-type: none"> • faulty operation • component failure 	Contact the distributor near to you.

Fault code	Fault name	Possible cause	Correcting actions
25	Microcontroller watchdog fault	Faulty operation component failure	Reset the fault and restart. If the fault re-occur, contact the distributor near to you.
27	Back EMF protection	Drive has detected that the magnetized motor is running in start situation. • A rotating PM-motor	Make sure that there is no rotating PM-motor when the start command is given.
29	Thermistor fault	The thermistor input of option board has detected increase of the motor temperature.	Check motor cooling and loading. Check thermistor connection (If thermistor input of the option board is not in use it has to be short circuited).
34	Internal bus communication	Ambient interference or defective hardware.	If the fault re-occur, contact the distributor near to you.
35	Application fault	Application is not working properly.	Contact the distributor near to you.
41	IGBT Overtemperature	Overtemperature alarm is issued when the IGBT switch temperature exceeds 230 °F (110 °C)	Check loading. Check motor size. Make identification run.
50	Analogue input select 20% - 100% (selected signal range 4 to 20 mA or 2 to 10 V)	Current at the analogue input is < 4mA; Voltage at the analogue input is < 2 V. • Control cable is broken or loose. • Signal source has failed.	Check the current loop circuitry.
51	External fault	Digital input fault. Digital input has been programmed as external fault input and this input is active.	Remove the external device fault.
52	Door Panel fault	Control place is keypad, but door panel has been disconnected.	Check the connection between optional board and API. If connection is correct, contact the nearest Honeywell distributor.
53	Fieldbus fault	The data connection between the fieldbus Master and the fieldbus of the drive has broken.	Check installation. If installation is correct, contact the nearest Honeywell distributor.
54	Slot fault	The connection between optional board and API has been broken.	Check board and slot. Contact the nearest Honeywell distributor.

Fault code	Fault name	Possible cause	Correcting actions
55	Wrong run fault (FWD/REV conflict)	Run forward and backward are high at the same time.	Check I/O control signal 1 and I/O control signal 2.
57	Motor identification fault	Motor identification run has failed.	Run command was removed before completion of identification run. Motor is not connected to frequency converter. There is load on motor shaft.
111	Temperature fault	Over low or over high temperature	Check temperature signal from OPTBH board.

Table 12. Fault subcodes from power

F08 SubCode	Fault
60	Watchdog reset
61	SW stack overflow.
62	HW stack overflow
63	Misalignment
64	Illegal op
65	PLL lost lock / Low CPU voltage
66	EEPROM Device
67	EEPROM Queue full
68	MPI communication (dead or CRC errors)
70	CPU load
71	External oscillator
72	Fault in Power triggered by user

Table 13. Fault subcodes from control API

F08 SubCode	Fault
84	MPI CRC
86	MPI2 CRC
89	HMI receive buffer overflow
90	MODBUS receive buffer overflow
93	Power source cannot be recognized
96	MPI queue full
97	MPI off line error
98	MPI driver error
99	Option Board Driver Error
100	Option Board Configure Error
104	OBI channel full
105	OBI memory allocate fail
106	OBI object queue full
107	OBI HMI queue full
108	OBI SPI queue full
111	Parameter copy error
113	Frequency detective timer overflow
114	PC control time out error
115	Device Property data format tree too deep exceed 3
120	Task stack overflow

Table 14. Fault subcodes

F22 SubCode	Fault
1	DA_CN, Power down data counter error
2	DA_PD, Power down data restore fail
3	DA_FH, Fault history data error
4	DA_PA, Restore parameter CRC error
5	Reserved
6	DA_PER_CN, Persist data counter error
7	DA_PER_PD, Persist data restore fail

Table 15. Fault subcodes

F35 SubCode	Fault
1	Application software flash error
2	Application header error

6 HVAC232/402 APPLICATION INTERFACE

6.1 Introduction

There is only one version of Control Board available for the HVAC232/402 drive:

Table 16. Available Control Board

Version	Composition
HVAC232/402	6 Digital inputs
	2 Analogue inputs
	1 Analogue output
	1 Digital output
	2 Relay outputs
	RS-485 Interface

This section provides you with a description of the I/O-signals for HVAC232/402 and instructions for using the HVAC232/402 general purpose application.

The frequency reference can be selected from Preset Speed 0, Keypad, Fieldbus, AI1, AI2, AI1+AI2, PID, Motor potentiometer.

BASIC PROPERTIES:





- Digital inputs DI1...DI6 are freely programmable. The user can assign a single input to many functions.
- Digital-,relay- and analogue outputs are freely programmable.
- Analogue output can be programmed as current or voltage output.
- Analogue input1 can be as voltage input, analogue input 2 can be programmed as current or voltage input.

SPECIAL FEATURES:

- Programmable Start/Stop and Reverse signal logic
- Motor pre-heat
- Reference scaling
- DC-brake at start and stop
- Programmable U / f curve
- Adjustable switching frequency
- Autoreset function after fault
- Protections and supervisions (all fully programmable; off, alarm,fault):
 - Analogue input low fault
 - External fault
 - Undervoltage fault
 - Earth fault
 - Motor thermal, stall and under load protection
 - Fieldbus communication
 - Output phase fault
 - Thermistor fault
- 8 preset speeds
- Analogue input range selection, signal scaling and filtering
- PID-controller

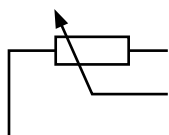
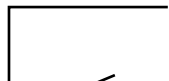
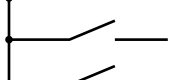
6.2 Control I/O

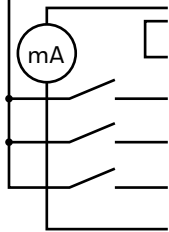
Table 17. HVAC232/402 General purpose application default I/O configuration and connections for control board

1-10 k Ω	Terminal	Signal	Factory preset	Description
	1	+10 Vref		Ref. voltage out Maximum load 10 mA
	2	AI1	Freq. reference ^{P)}	Analogue signal in 1 0 ... 10 V, Ri = 250 k Ω
	3	GND		I/O signal ground
	6	24 Vout		24 V output for DI's \pm 20%, max. load 50 mA
	7	DI_C		Digital Input Common Digital Input Common for DI1-DI6, refer to „Table 18. DI Sink Type“ on page 40
	8	DI1	Start forward ^{P)}	Digital input 1 Positive Logic 1: 18 ... 30 V, Negative Logic 1: 0 ... 10 V,
	9	DI2	Start reverse ^{P)}	Digital input 2 Positive Logic 0: 0 ... 5 V, Negative Logic 0: 18 ... 30 V;
	10	DI3	Fault reset ^{P)}	Digital input 3 Ri = 10 k Ω (floating)
	A	A	RS-485 signal A	FB Communication Negative
	B	B	RS-485 signal B	FB Communication Positive
	4	AI2	PID actual value and Freq. reference ^{P)}	Analogue signal in 2 Default: 0(4) ... 20 mA, Ri \leq 250 Ω Other: 0 ... +10 V, Ri = 250 k Ω Selectable through microswitch
	5	GND		I/O signal ground
	13	DO-		Digital Output Common
	14	DI4		Digital input 4 As DI1
	15	DI5		Digital input 5 As DI1, Selectable through microswitch
	16	DI6		Digital input 6 As DI1
	18	AO	Output frequency ^{P)}	Analogue Output 0(4) ... 20 mA, RL \leq 500 Ω , 0 ... 10 V, RL \geq 1 k Ω , Selectable through microswitch
	20	DO	Active = READY ^{P)}	Digital signal out Open collector, max. load 35 V / 50 mA
	22	RO1 NO	Relay out 1 	Active = RUN ^{P)} Switching load: 23 RO1 CM 250 Vac / 3 A, 24 Vdc 3 A
	23	RO1 CM		
	24	RO2 NC	Relay out 2 	Active = FAULT ^{P)} Switching load: 25 RO2 CM 250 Vac / 3 A, 24V DC 3A
	25	RO2 CM		
	26	RO2 NO		

P) = Programmable function, see parameter lists and descriptions, Chapters „9 Standard application parameters“ on page 55 and „10 Parameter description“ on page 96.

Table 18. DI Sink Type, remove jumper J500 and connect the wire using this table

	Terminal	Signal	Factory preset	Description	
	3	GND	I/O signal ground		
	6	24 Vout	24 V output for DI's	±20%, max. load 50 mA	
	7	DI_C	Digital Input Common		Digital Input Common for DI1-DI6
	8	DI1	Digital input 1	Start forward ^{P)}	Positive Logic 1: 18...+30 V, Positive Logic 0: 0...5 V; Negative Logic 1: 0...10 V, Negative Logic 0: 18...30 V; Ri = 10 kΩ (floating)
	9	DI2	Digital input 2	Start reverse ^{P)}	
	10	DI3	Digital input 3	Fault reset ^{P)}	
	14	DI4	Digital input 4		Positive Logic 1: 18...+30 V, Positive Logic 0: 0...5 V; Negative Logic 1: 0...10 V, Negative Logic 0: 18...30 V; Ri = 10 kΩ (floating)
	15	DI5	Digital input 5		Only for DI.
16	DI6	Digital input 6		Only for DI.	

P) = Programmable function, see parameter lists and descriptions, Chapters „9 Standard application parameters“ on page 55 and „10 Parameter description“ on page 96.

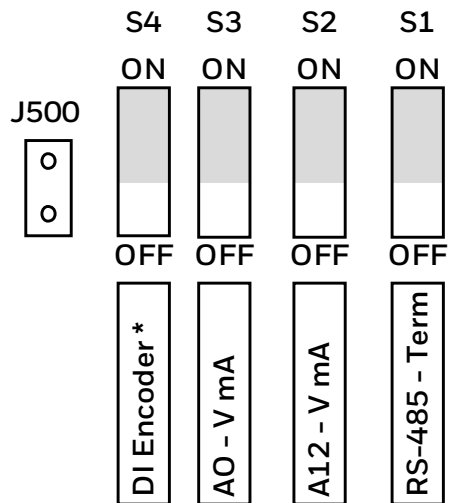

* Logic input configured as encoder input. Not used. **Must leave at default**

Fig. 35. Microswitches

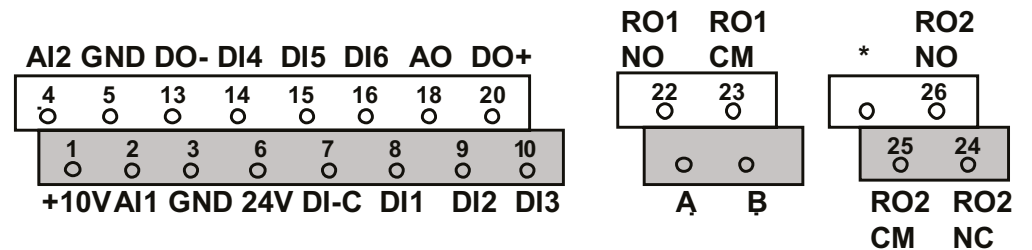

Figure 36. HVAC232/402 I/O terminals:

7 CONTROL PANEL

7.1 General

The panel is an irremovable part of the drive consisting of corresponding control board; The overlay with display status on the cover and the button are in clarifications in the user language.

The User Panel consists of an alphanumeric LCD display with backlight and a keypad with the 9 push buttons (see „Fig. 37. HVAC232/402 Control panel“ on page 45).

7.2 Display

The display includes 14-segment and 7-segment blocks, arrowheads and clear text unit symbols. The arrowheads, are directed on some information or navigation location in the menu (see numbers 1...14 on the next page).

The arrowheads are grouped in 3 groups with the following meanings and English overlay texts (see „Fig. 37. HVAC232/402 Control panel“ on page 45).

Group 1 - 5; Drive status

1. Drive is ready to start(READY)
2. Drive is running(RUN)
3. Drive has stopped(STOP)
4. Alarm condition is active(ALARM)
5. Drive has stopped due to a fault(FAULT)

Group 6 - 10; Control selections

When API is operated by PC control, there are no arrowhead at I/O, KEYPAD and BUS.

6. Motor is rotating forward(FWD)
7. Motor is rotating reverse(REV)
8. I/O terminal block is the selected control place (I /O)
9. Keypad is the selected control place (KEY- PAD)
10. Fieldbus is the selected control place(BUS)

Group 11 - 14; Navigation main menu

11. Reference main menu(REF)
12. Monitoring main menu(MON)
13. Parameter main menu(PAR)
14. System main menu(SYS)

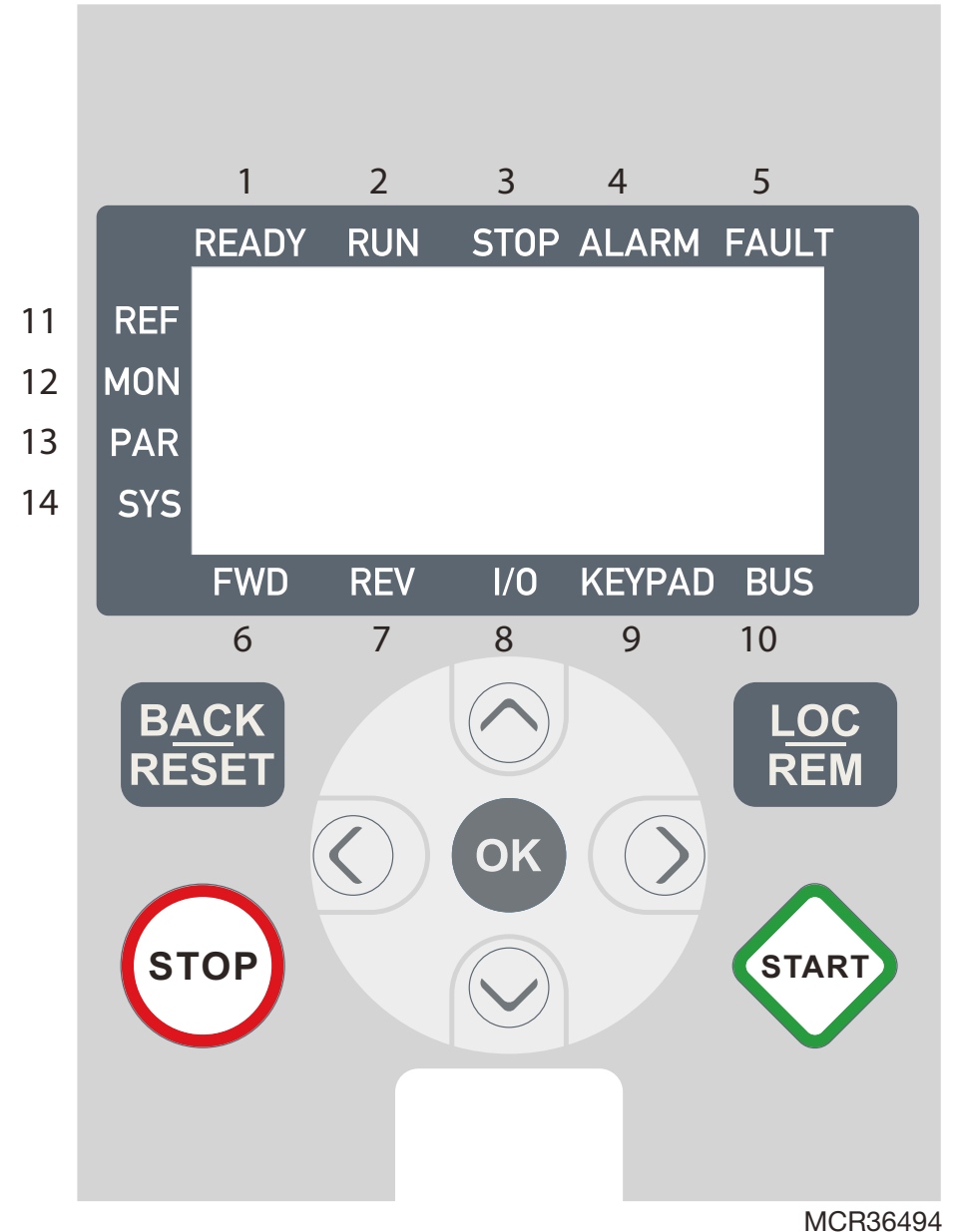





Fig. 37. HVAC232/402 Control panel





7.3 Keypad

The keypad section of the control panel consists of 9 buttons (see „Fig. 37. HVAC232/402 Control panel“ on page 45). The buttons and their functions are described as in the table below.

Table 19. Keypad Function

Symbol	Button Name	Function Description
	Start	Motor START from the panel
	STOP	Motor STOP from the panel
	OK	Used for confirmation. Enter edit mode for parameter. Alternate in display between the parameter value and parameter code.
	Back / Reset	Cancels edited parameter Move backwards in menu levels Reset fault indication

The drive stops by pressing the keypad STOP button, regardless of the selected control place when Par. 2.7 (Keypad stop button) is 1. If Par. 2.7 is 0, the drive stops by keypad STOP button only when control place is keypad. The drive starts by pressing the keypad START button when the selected control place is KEYPAD or LOCAL control.

Symbol	Button Name	Function Description
   	Up and Down Left and Right	Select root parameter number on root-parameter list, - Up decrease / Down increase parameter number, - Up increase / Down decrease parameter value change. Available in REF,PAR and SYS menu parameter digit setting when changing value. MON,PAR and SYS can also use left and right button to navigate the parameter group, like e.g.,in MON menu use right button from V1.x to V2.x to V3.x. Can be used to change direction in REF menu in local mode: - Right arrow would mean reverse (REV) - Left arrow would mean forward (FWD)
	Loc / Rem	Change control place

	NOTE: The status of all the 9 buttons are available for application program!
---	--

8 NAVIGATION ON THE HVAC232/402 CONTROL PANEL

This chapter provides you with information on navigating the menus on HVAC232/402 and editing the values of the parameters.

8.1 Main menu

The menu structure of HVAC232/402 control software consists of a main menu and several submenus. Navigation in the main menu is shown below:

Fig. 38. The main menu of HVAC232/402

REFERENCE MENU

Displays the keypad reference value regardless of the selected control place.

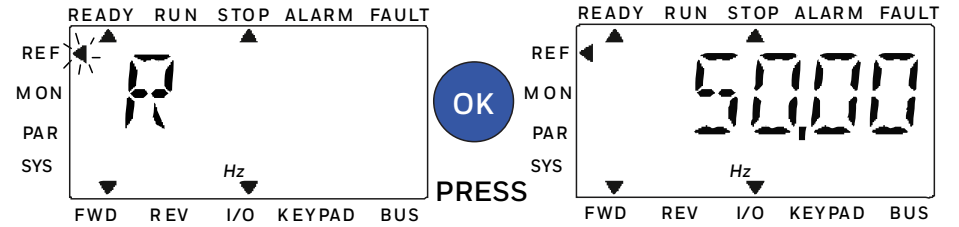

MONITORING MENU

In this menu you can browse the monitoring values

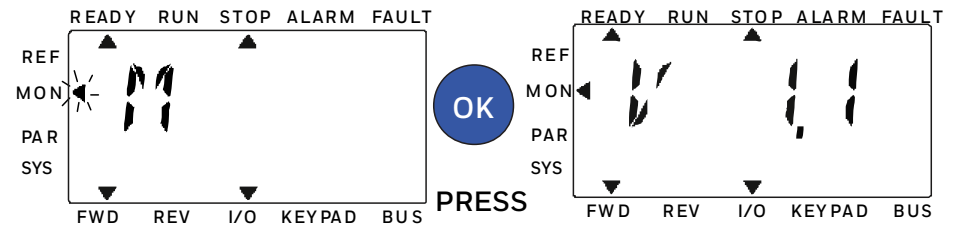

PARAMETER MENU

In this menu you can browse and edit the parameters

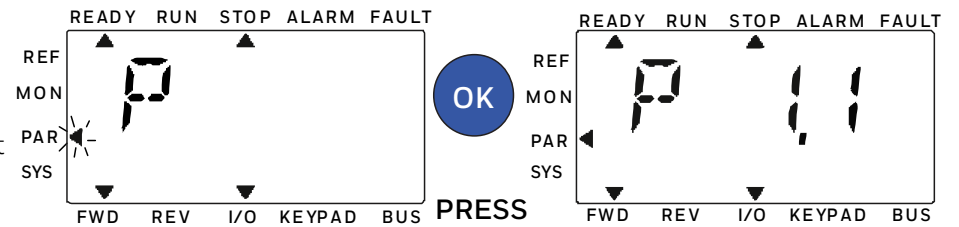

SYSTEM MENU

Here you will be able to browse system parameter and fault submenu

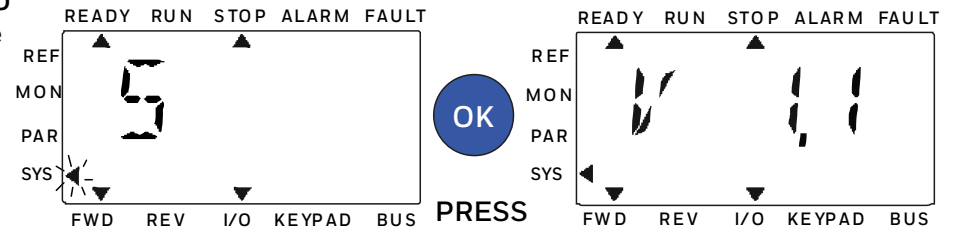

8.2 Reference menu

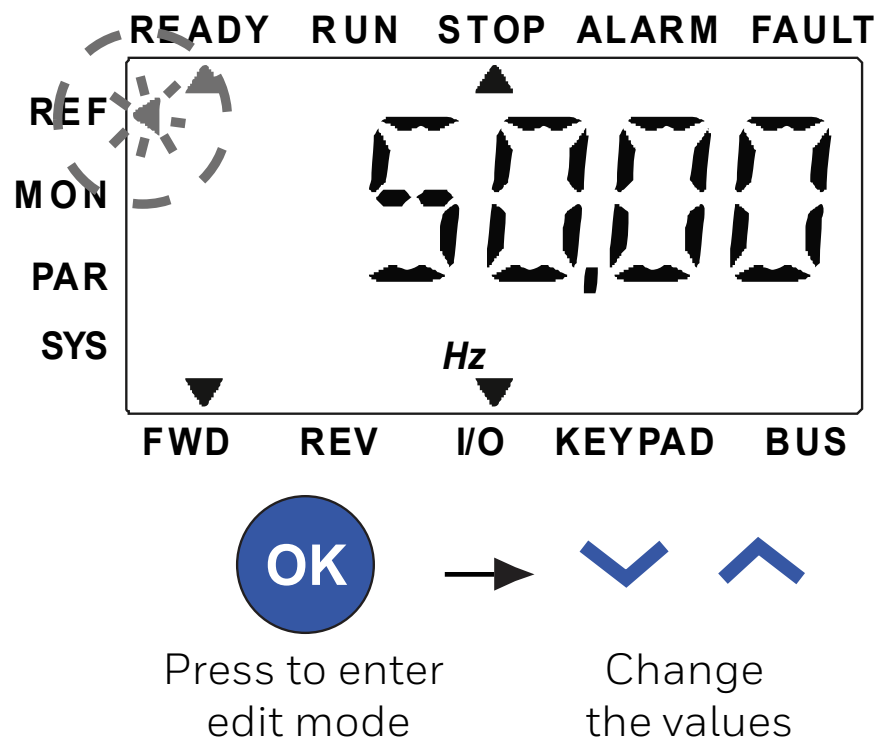

Fig. 39. Reference menu display

Move to the reference menu with the UP / DOWN button (see „Fig. 38. The main menu of HVAC232/402“ on page 48). The reference value can be changed with UP / DOWN button as shown in „Fig. 39. Reference menu display“ on page 49. If the value has big change, first press Left and Right buttons to select the digit which has to be changed, then press Up button to increase and Down button to decreases the value in the selected digit. The changing reference frequency will be taken into use immediately without pressing OK.

NOTE:
LEFT and RIGHT buttons can be used to change the direction in Ref menu in local control mode.

8.3 Monitoring menu

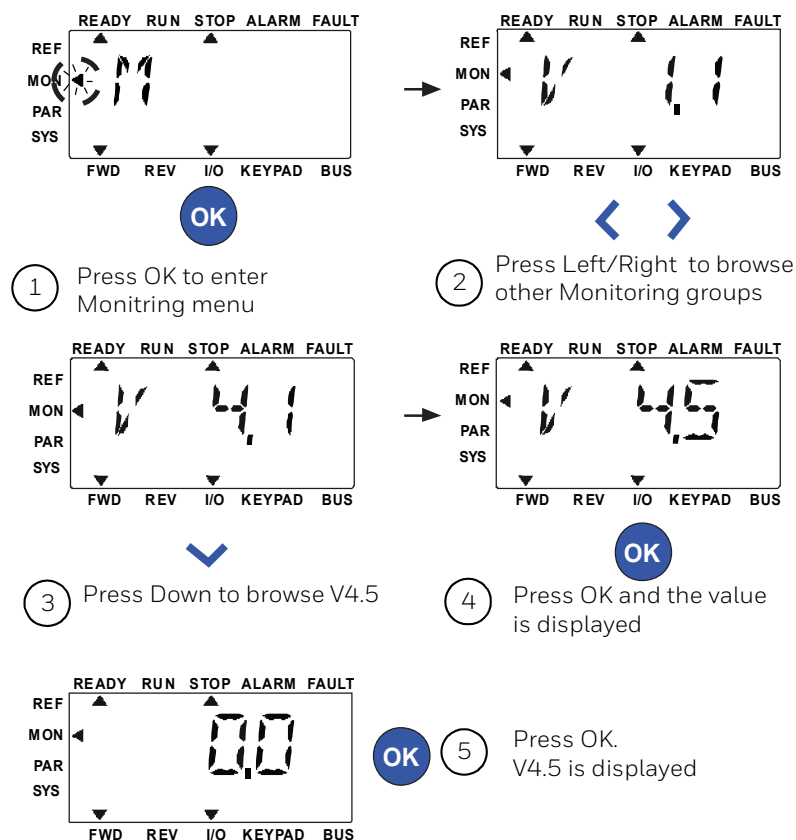

Fig. 40. Monitoring menu display

Monitoring values are actual values of measured signals as well as status of some control settings. It is visible in HVAC232/402 display, but it can not be edited. The monitoring values are listed in „Table 20. Monitoring values“ on page 51.

Pressing Left/Right button to change the actual parameter to the first parameter of the next group, to browse monitor menu from V1.x to V2.1 to V3.1 to V4.1. After entering the desired group, the monitoring values can be browsed by pressing UP /DOWN button, as shown in „Fig. 40. Monitoring menu display“ on page 50.

In MON menu the selected signal and its value are alternating in the display by pressing OK button.



	<p>NOTE: Turn on drive power, arrowhead of main menu is at MON, V x.x or monitor parameter value of Vx.x is displayed in Panel.</p>
	<p>NOTE: Display Vx.x or monitor parameter value of Vx.x is determined by the last show status before power shut down. E.g., it was V4.5, and it is also V4.5 when restart.</p>

Table 20. Monitoring values

Code	Monitoring signal	Unit	ID	Description
V1.1	Output frequency	Hz	1	Output frequency to motor
V1.2	Frequency reference	Hz	25	Frequency reference to motor control
V1.3	Motor speed	rpm	2	Calculated motor speed
V1.4	Motor current	A	3	Measured motor current
V1.5	Motor torque	%	4	Calculated actual / nominal torque of the motor
V1.6	Motor shaft power	%	5	Calculated actual / nominal power of the motor
V1.7	Motor voltage	V	6	Motor voltage
V1.8	DC-link voltage	V	7	Measured DC-link voltage
V1.9	Unit temperature	°C	8	Heatsink temperature
V1.10	Motor temperature	%	9	Calculated motor temperature
V1.11	Output Power	kW	79	Output power from drive to motor
V2.1	Analogue input 1	%	59	AI1 signal range in percent of used range
V2.2	Analogue input 2	%	60	AI2 signal range in percent of used range
V2.3	Analogue output	%	81	AO signal range in percent of used range
V2.4	Digital input status DI1, DI2, DI3		15	Digital input status
V2.5	Digital input status DI4, DI5, DI6		16	Digital input status
V2.6	RO1, RO2, DO		17	Relay / digital output status
V2.11	Analogue input E1	%	61	Analogue input signal 1 in % from option board, hidden until an option board is connected
V2.12	Analogue output E1	%	31	Analogue output signal 1 in % from option board, hidden until an option board is connected
V2.13	Analogue output E2	%	32	Analogue output signal 2 in % from option board, hidden until an option board is connected
V2.14	DIE1, DIE2, DIE3		33	This monitor value shows status of the digital inputs 1-3 from option board, hidden until an option board is connected
V2.15	DIE4, DIE5, DIE6		34	This monitor value shows status of the digital inputs 4-6 from option board, hidden until an option board is connected
V2.16	DOE1, DOE2, DOE3		35	This monitor value shows status of the relay outputs 1-3 from option board, hidden until an option board is connected
V2.17	DOE4, DOE5, DOE6		36	This monitor value shows status of the relay outputs 4-6 from option board, hidden until an option board is connected
V2.18	Temperature input 1		50	Measured value of Temperature input 1 in temperature unit (Celsius or Kelvins) by parameter setting, hidden until an option board is connected
V2.19	Temperature input 2		51	Measured value of Temperature input 2 in temperature unit (Celsius or Kelvins) by parameter setting, hidden until an option board is connected
V2.20	Temperature input 3		52	Measured value of Temperature input 3 in temperature unit (Celsius or Kelvins) by parameter setting, hidden until an option board is connected

Table 20. Monitoring values

Code	Monitoring signal	Unit	ID	Description
V3.1	Drive status word		43	Bit codes status of drive
				B0 = Ready B1 = Run B2 = Reverse B3 = Fault
V3.2	Application status word		89	Bit codes status of application:
				B3 = Ramp 2 Active B5 = Remote CTRL Place 1 active B6 = Remote CTRL Place 2 active B7 = Fieldbus Control Active
V3.3	DIN status word		56	Bit codes status of application:
				B0 = DI1 B1 = DI2 B2 = DI3 B3 = DI4 B4 = DI5 B5 = DI6
V4.1	PID setpoint	%	20	Regulator setpoint
V4.2	PID feedback value	%	21	Regulator actual value
V4.3	PID error	%	22	Regulator error
V4.4	PID output	%	23	Regulator output
V4.5	Process		29	Scaled process variable see „P14.18“ on page 86
V5.1	Fire mode status		1597	0 = Disabled 1 = Enabled 2 = Activated (Enabled + DI Open) 3 = Test Mode
V5.2	Fire mode counter		1679	Fire mode counter tells how many times fire mode has been activated. This counter can not be reset.
V5.3	Warranty affected device		1682	1 = Device is warranty affected as critical faults triggered in fire mode 0 = Normal device

8.4 Parameter menu

In Parameter menu only the Quick setup parameter list is shown as default. By giving the value 0 to the parameter 17.2, it is possible to open other advanced parameter groups. The parameter lists and descriptions can be found in „9 Standard application parameters“ on page 55 and „10 Parameter description“ à la page 96.

The following figure shows the parameter menu view:

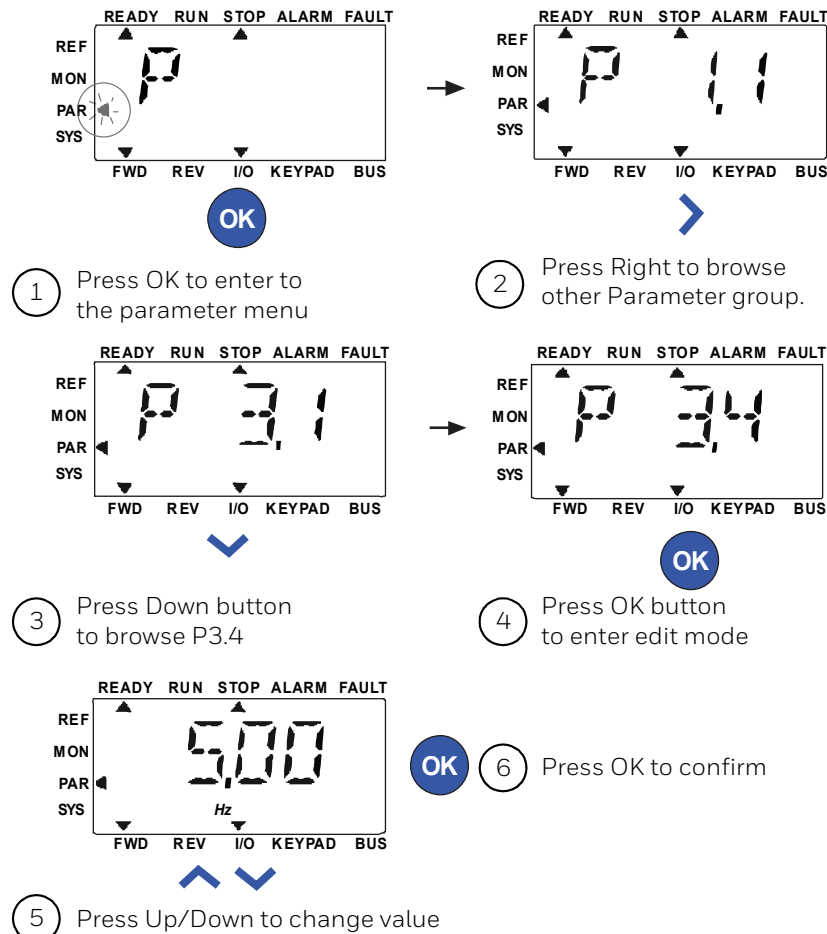

Fig. 41. Parameter menu

The parameter can be changed as the Figure „Fig. 41. Parameter menu“ on page 51.

Left / Right button is available inside Parameter menu. Pressing Left / Right button to change the actual parameter to the first parameter of the next group (Example: any parameter of P1... is displayed -> RIGHT button -> P2.1 is displayed -> RIGHT button -> P3.1 is displayed ...). After entering the desired group, pressing UP / DOWN button to select root parameter number, and then press OK button to display the value of the parameter and also enter edit mode.

In edit mode, Left and Right buttons are used to select the digit which has to be changed, and Up increases / Down decreases parameter value.

In edit mode, the value of Px.x is displayed blinkingly in the panel. After about 10 s, Px.x is displayed in the panel again if you don't press any button.

	NOTE: In edit mode, if you edit the value and don't press OK button, the value isn't changed successfully.
	NOTE: In edit mode, if you don't edit the value, you can press Reset / Back button to display Px.x again.

8.5 System menu

SYS menu including fault submenu, field bus submenu and system parameter submenu, and the display and operation of the system parameter submenu is similar to PAR menu or MON menu. In system parameter submenu, there are some editable parameter(P) and some uneditable parameter (V).

The Fault submenu of SYS menu includes active fault submenu and fault history submenu.

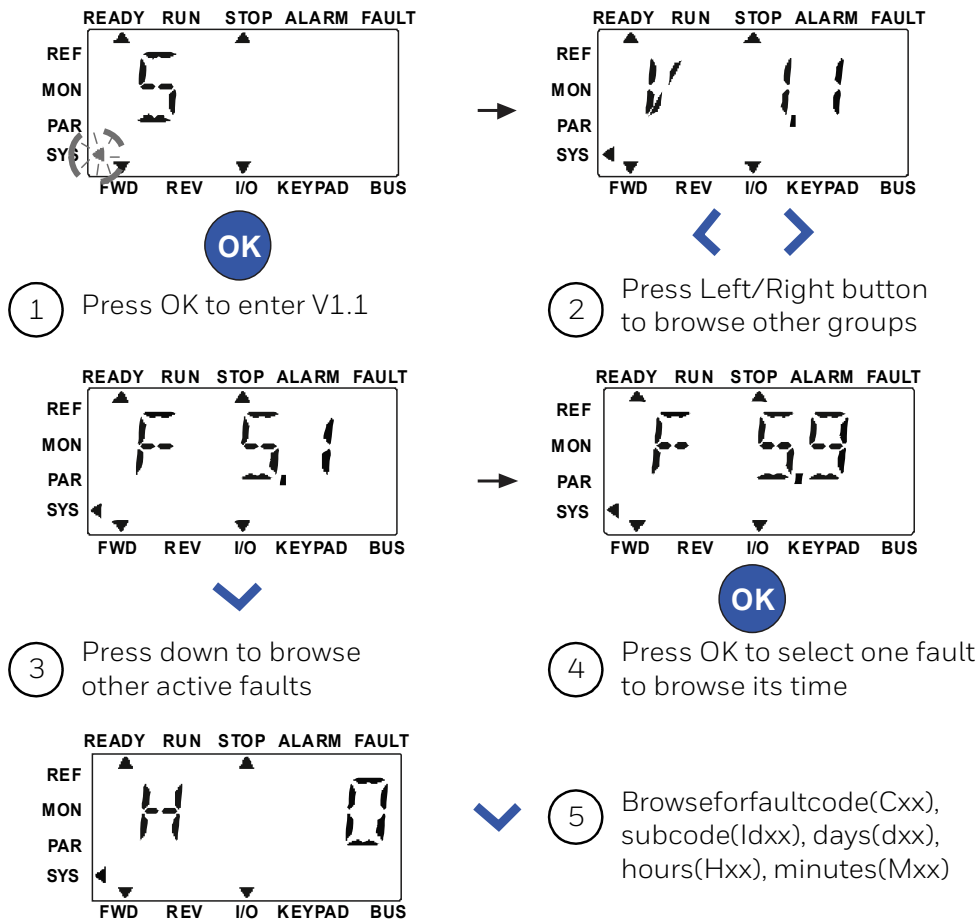



Fig. 42. Fault menu



In active fault situation, FAULT arrow is blinking and the display is blinking active fault menu item with fault code. If there are several active faults, you can check it by entering the active fault submenu F5.x. F5.1 is always the latest active fault code. The active faults can be reset by pressing BACK/RESET button with long time (>2 s), when the API is in active fault submenu level (F5.x). If the fault cannot be reset, the blinking continues. It is possible to select other display menus during active fault, but in this case the display returns automatically to the fault menu if no button is pressed in 10 seconds. The fault code, subcode and the operating day, hour and minute values at the fault instant are shown in the value menu (operating hours = displayed reading).

	<p>NOTE:</p> <p>Fault History can be reset by long pressing the BACK/RESET button for 5 second time, when the API is in fault history submenu level (F6.x), it will also clear all active faults.</p>
---	--

9 Standard application parameters

On the next pages you can find the lists of parameters within the respective parameter groups. The parameter descriptions are given in „10 Parameter description“ à la page 96.

Explanations:

Code:	Location indication on the keypad; Shows the operator the present Monitoring value number or Parameter number
Parameter:	Name of monitoring value or parameter
Min:	Minimum value of parameter
Max:	Maximum value of parameter
Unit:	Unit of parameter value; given if available
Default:	Factory preset value
ID:	ID number of the parameter (used with fieldbus control)
	More information on this parameter available in „10 Parameter description“ à la page 96. Click on the parameter name.
	Modifiable only in stop state

9.1 Quick setup parameters (Virtual menu, shows when par. 16.2 → 1)

Table 21. Quick setup parameters.

Code	Parameter	Min	Max	Unit	Default	ID	Note
P1.1	Motor nominal voltage	180	480	V	Varies	110	
P1.2	Motor nominal frequency	30,00	320,00	Hz	50,00/60,00	111	
P1.3	Motor nominal speed	30	20000	rpm	1440/1720	112	
P1.4	Motor nominal current	$0,2 \times I_{Nunit}$	$2,0 \times I_{Nunit}$	A	I_{Nunit}	113	
P1.5	Motor cos j (Power Factor)	0,30	1,00		0,85	120	
i P1.7	Current limit	$0,2 \times I_{Nunit}$	$2,0 \times I_{Nunit}$	A	$1,5 \times I_{Nunit}$	107	
i P1.15	Torque boost	0	1		0	109	
P1.23	Energy optimization	0	1		0	666	Energy optimization, the frequency converter search for the minimum current in order to save energy and lower motor noise.
i P2.1	Remote control place 1	0	2		0	172	
i P2.2	Start function	0	1		0	505	
i P2.3	Stop function	0	1		0	506	
P3.1	Min frequency	0,00	P3.2	Hz	0.00	101	
P3.2	Max frequency	P3.1	320,00 Hz	Hz	50,00/60,00	102	
i P3.3	Remote control place 1 frequency reference selection	1	Varies		7	117	
i P3.4	Preset speed 0	P3.1	P3.2	Hz	5,00	180	
i P3.5	Preset speed 1	P3.1	P3.2	Hz	10,00	105	

Table 21. Quick setup parameters.

Code	Parameter	Min	Max	Unit	Default	ID	Note
<i>i</i> P3.5	Preset speed 2	P3.1	P3.2	Hz	15,00	106	
<i>i</i> P3.7	Preset speed 3	P3.1	P3.2	Hz	20,00	126	
P4.2	Acceleration time 1	0,1	3000,0	s	3,0	103	
P4.3	Declaration time 1	0,1	3000,0	s	3,0	104	
P6.1	AI1 range	0	1		0	379	
P6.5	AI2 range (see the P6.1)	0	1		0	390	
P10.1	Prohibit frequency range 1 low limit	0,00	P3.2	Hz	0,00	509	
P10.2	Prohibit frequency range 1 high limit	0,00	P3.2	Hz	0,00	510	
P13.1	Automatic reset	0	1		0	731	
P14.1	Setpoint source selection	0	Varies		0	332	0 = Fixed setpoint % 1 = AI1 2 = AI2 3 = ProcessDataIn1(0-100%) 4 = ProcessDataIn2(0-100%) 5 = ProcessDataIn3(0-100%) 6 = ProcessDataIn4(0-100%) 7 = AIE1 8 = Temperature input 1 9 = Temperature input 2 10 = Temperature input 3
P14.2	Fixed setpoint 1	0,0	100,0	%	50,0	167	Fixed setpoint
P14.3	Fixed setpoint 2	0,0	100,0	%	50,0	168	Alternative fixed setpoint, selectable with DI

Table 21. Quick setup parameters.

Code	Parameter	Min	Max	Unit	Default	ID	Note
P14.4	Feedback source selection	0	Varies		1	334	0 = AI1 1 = AI2 2 = ProcessDataIn1(0-100%) 3 = ProcessDataIn2(0-100%) 4 = ProcessDataIn3(0-100%) 5 = ProcessDataIn4(0-100%) 6 = AI2-AI1 7 = AIE1 8 = Temperature input 1 9 = Temperature input 2 10 = Temperature input 3
P14.5	Feedback value min	0,0	50,0	%	0,0	336	Value at minimum signal
P14.6	Feedback value max	10,0	300,0	%	100,0	337	Value at maximum signal
P14.11	Sleep min frequency	0,00	P3.2	Hz	25,00	1016	Threshold for enter sleep
P14.12	Sleep delay	0	3600	s	30	1017	Delay for enter sleep
P14.13	Wake up level	0,0	100,0	%	90,0	1018	Threshold for exit sleep
P14.14	Sleep setpoint boost	0,0	50,0	%	10,0	1071	Referred to setpoint
P14.15	Setpoint boost time	0	60	s	10	1072	Boost time after P14.12
P16.2	Parameter conceal	0	1		1	115	Hides all parameters not in quick start 0 = All parameters visible 1 = Only quick setup parameter group visible
P18.1	Fire mode password	0	9999		0	1599	1234 = Test mode 1001 = Enable 1515 = Disable

Table 21. Quick setup parameters.

Code	Parameter	Min	Max	Unit	Default	ID	Note
P18.2	Fire mode frequency select	0	Varies		0	1617	Fire mode frequency preset i NOTE! This parameter will be locked when fire mode is active. To change the parameter you have to disable fire mode.
P18.3	Fire mode frequency preset	P3.1	P3.2	Hz	8,00	1598	Fire mode frequency preset i NOTE! This parameter will be locked when fire mode is active. To change the parameter you have to disable fire mode.
P18.4	Fire mode activation close	0	Varies		6	1619	Digital input normal close As parameter 5.1 i NOTE! This parameter will be locked when fire mode is active. To change the parameter you have to disable fire mode.
P18.5	Fire mode activation open	0	Varies		0	1596	Digital input normal open As parameter 5.1 i NOTE! This parameter will be locked when fire mode is active. To change the parameter you have to disable fire mode.
P18.6	Fire mode reverse	0	Varies		0	1618	Reverse command of rotation direction while running in fire mode. This DI has no effect in normal operation. As parameter 5.1 i NOTE! This parameter will be locked when fire mode is active. To change the parameter you have to disable fire mode.

9.1.1 Motor settings (Control panel: Menu PAR -> P1)





Table 22. Motor settings

Code	Parameter	Min	Max	Unit	Default	ID	Note
P1.1	Motor nominal voltage	180	480	V	Varies	110	
P1.2	Motor nominal frequency	30,00	320,00	Hz	50,00/60,00	111	
P1.3	Motor nominal speed	30	20000	rpm	1440/1720	112	
P1.4	Motor nominal current	$0,2 \times I_{Nunit}$	$2,0 \times I_{Nunit}$	A	I_{Nunit}	113	
P1.5	Motor cos φ (Power Factor)	0,30	1,00		0,85	120	
P1.6	Motor type	0	1		0	650	0 = Induction 1 = Permanent magnet
i P1.7	Current limit	$0,2 \times I_{Nunit}$	$2,0 \times I_{Nunit}$	A	$1,5 \times I_{Nunit}$	107	
i P1.8	Motor control mode	0	1		0	600	0 = Frequency control 1 = Open loop speed control
i P1.9	U / f ratio	0	2		0	108	0 = Linear 1 = Square 2 = Programmable
i P1.10	Field weakening point	8,00	320,00	Hz	50,00/60,00	602	
i P1.11	Field weakening point voltage	10,00	200,00	%	100,00	603	
i P1.12	U / f mid point frequency	0,00	P1.10	Hz	50,00/60,00	604	
i P1.13	U / f mid point voltage	0,00	P1.11	%	100,00	605	
i P1.14	Zero freq voltage	0,00	40,00	%	Varies	606	
i P1.15	Torque Boost	0	1		0	109	0 = Disabled 1 = Enabled
i P1.16	Switching frequency	1,5	16,0	kHz	4,0/2,0	601	

Table 22. Motor settings

Code	Parameter	Min	Max	Unit	Default	ID	Note
i P1.17	Motor identification	0	1		0	631	0 = not active 1 = standstill identification (need run command within 20 s to activate) 2 = ID with run
P1.18	Rs voltage drop	0,00	100,00	%	0,00	662	Voltage drop over motor windings as % of Un at nominal current. This parameter is adjusted automatically when Identification run is performed.
i P1.19	Overvoltage controller	0	2		1	607	0 = Disabled 1 = Enabled: default mode 2 = Enabled: shock load mode
i P1.20	Undervoltage controller	0	1		1	608	0 = Disable 1 = Enabled
P1.21	Sine filter	0	1		0	522	0 = Not in use 1 = In use
P1.22	Modulator type feature not used, leave at default	0	65535		28928	648	Bit 1 = Discontinuous modulation Bit 2 = Pulse dropping in over modulation Bit 6 = Under modulation Bit 8 = Instantaneous DC voltage compensation Bit 11 = Low noise Bit 12 = Dead time compensation Bit 13 = Flex error compensation
i P1.23	Energy optimization	0	1		0	666	Energy optimization, the frequency converter searches for the minimum current in order to save energy and lower motor noise: 0 = Disabled 1 = Enable

Table 22. Motor settings

Code	Parameter	Min	Max	Unit	Default	ID	Note
 P1.24	I/f start enable	0	1		0	534	<p>The I/f Start function is typically used with permanent magnet motors (PM) to start the motor with constant current control. This is useful with high power motors in which the resistance is low and the tuning of the U/f curve difficult.</p> <p>Applying the I/f Start function may also prove useful in providing sufficient torque for the motor at startup.</p> <p>0 = Disabled 1 = Enable</p>
 P1.25	I/f start frequency reference limit	1	100	%	10	535	Output frequency limit below which the defined I/f start current is fed to motor.
 P1.26	I/f start current reference	0	100.0	%	80.0	536	The current fed to the motor when the I/f start function is activated.
 P1.27	Voltage limiter enable	0	1		1	1079	<p>Voltage limiter function addresses problem with very high DC-link voltage ripple with 1-phase drives when fully loaded. Very high ripple in DC link voltage will transform to high current and torque ripple, which can disturb some users.</p> <p>Voltage limiter function limits maximum output voltage to bottom of DC-voltage ripple. This reduces current and torque ripple, but decreases maximum output power since voltage is limited and more current is needed.</p> <p>0 = Disabled 1 = Enable</p>



NOTE:

These parameters are shown, when P16.2 = 0.

9.1.2 Start / stop setup (Control panel: Menu PAR → P2)

Table 23. Start / stop setup.

	Code	Parameter	Min	Max	Unit	Default	ID	Note	
i	P2.1	Remote Control Place 1 Selection	0	2		0	172	0 = I/O terminals 1 = Fieldbus 2 = Keypad	
i	P2.2	Start function	0	1		0	505	0 = Ramping 1 = Flying start	
i	P2.3	Stop function	0	1		0	506	0 = Coasting 1 = Ramping	
i	P2.4	I/O Start / Stop logic	0	4		0	300	I/O control	I/O control
signal1								signal2	
0 = Forward								0 = Reverse	
1 = Fwd(edge)								1 = Inverted Stop	
2 = Fwd(edge)								2 = Bwd(edge)	
3 = Start								3 = Reverse	
4 = Start(edge)	4 = Reverse								
i	P2.5	Local / Remote	0	1		0	211	0 = Remote control 1 = Local control	
	P2.6	Keypad control direction	0	1		0	123	0 = Forward 1 = Backward	
	P2.7	Keypad stop button	0	1		1	114	0 = Inactive 1 = Active	
	P2.8	Remote Control Place 2 Selection	0	2		0	173	0 = I/O terminals 1 = Fieldbus 2 = Keypad	
	P2.9	keypad button lock	0	1		0	15520	0 = unlock all keypad button 1 = Loc/Rem button locked	

9.1.3 Frequency references (Control panel: Menu PAR → P3)

Table 24. Frequency references.

Code	Parameter	Min	Max	Unit	Default	ID	Note
P3.1	Min frequency	0,001	P3.2	Hz	0,00	101	
P3.2	Max frequency	P3.1	320,00	Hz	50,00/60,00	102	
i P3.3	Remote Control Place 1 frequency reference selection	1	Varies		7	117	1 = Preset speed 0 2 = Keypad 3 = Fieldbus 4 = AI1 5 = AI2 6 = PID 7 = AI1+ AI2 8 = Motor potentiometer 9 = AIE1 10 = Temperature input 1 11 = Temperature input 2 12 = Temperature input 3
i P3.4	Preset speed 0	P3.1	P3.2	Hz	5,00	180	
i P3.5	Preset speed 1	P3.1	P3.2	Hz	10,00	105	
i P3.6	Preset speed 2	P3.1	P3.2	Hz	15,00	106	
i P3.7	Preset speed 3	P3.1	P3.2	Hz	20,00	126	
i P3.8	Preset speed 4	P3.1	P3.2	Hz	25,00	127	
i P3.9	Preset speed 5	P3.1	P3.2	Hz	30,00	128	
i P3.10	Preset speed 6	P3.1	P3.2	Hz	40,00	129	
i P3.11	Preset speed 7	P3.1	P3.2	Hz	50,00	130	

Table 24. Frequency references.

Code	Parameter	Min	Max	Unit	Default	ID	Note
P3.12	Remote Control Place 2 frequency reference selection	P3.1	Varies		5	131	As parameter P3.3
P3.13	Motor Potentionmeter Ramp	1	50	Hz/s	5	331	
 P3.14	Motor Potentionmeter Reset	1	2		2	367	0 = No reset 1 = Reset if stopped 2 = Reset if powered down

	<p>NOTE: These parameters are shown, when P16.2 = 0.</p>
--	--

9.1.4 Ramps and brakes setup (Control panel: Menu PAR → P4)

Table 25. Ramps and brakes setup.

Code	Parameter	Min	Max	Unit	Default	ID	Note
<i>i</i> P4.1	Ramp S-shape 1	0,0	10,0	s	0,0	500	
P4.2	Acceleration time 1	0,1	3000,0	s	3,0	103	
P4.3	Deceleration time 1	0,1	3000,0	s	3,0	104	
P4.4	Ramp S-shape 2	0,0	10,0	s	0,0	501	
P4.5	Acceleration time 2	0,1	3000,0	s	10,0	502	
<i>i</i> P4.6	Deceleration time 2	0,1	3000,0	s	10,0	503	
<i>i</i> P4.7	Flux Braking	0	3		0	520	0 = Off 1 = Deceleration 2 = Chopper 3 = Full mode
P4.8	Flux Braking Current	$0,5 \times I_{Nunit}$	$2,0 \times I_{Nunit}$	A	I_{Nunit}	519	
P4.9	DC Braking Current	$0,3 \times I_{Nunit}$	$2,0 \times I_{Nunit}$	A	I_{Nunit}	507	
<i>i</i> P4.10	Stop DC current time	0,00	600,00	s	0,00	508	0 = Not active
<i>i</i> P4.11	Stop DC current frequency	0,10	10,00	Hz	1,50	515	
<i>i</i> P4.12	Start DC current time	0,00	600,00	s	0,00	516	
P4.13	Accel2 Frequency Threshold	0,00	P3.2	Hz	0,00	527	0,00 = Disabled
P4.14	Decel2 Frequency Threshold	0,00	P3.2	Hz	0,00	528	0,00 = Disabled
P4.15	External Brake: Open Delay	0,00	320,00	s	0,20	1544	
P4.16	External Brake: Open Frequency limit	0,00	P3.2	Hz	1,50	1535	
P4.17	External Brake : Close Frequency limit	0,00	P3.2	Hz	1,00	1539	

Table 25. Ramps and brakes setup.

Code	Parameter	Min	Max	Unit	Default	ID	Note
P4.18	External Brake : Close Frequency limit in Reverse	0,00	P3.2	Hz	1,50	1540	
P4.19	External Brake : Open/Close Current limit	0,0	200,0	%	20,0	1585	



9.1.5 Digital inputs (Control panel: Menu PAR → P5)

Table 26. Digital inputs.



Code	Parameter	Min	Max	Unit	Default	ID	Note
P5.1	I/O control signal 1	0	Varies		1	403	0 = Not used 1 = DI1 2 = DI2 3 = DI3 4 = DI4 5 = DI5 6 = DI6 7 = DIE1 8 = DIE2 9 = DIE3 10 = DIE4 11 = DIE5 12 = DIE6
i P5.2	I/O control signal 2	0	Varies		2	404	
i P5.3	Reverse	0	Varies		0	412	
P5.4	Ext. fault Close	0	Varies		0	405	
P5.5	Ext. fault Open	0	Varies		0	406	
P5.6	Fault reset	0	Varies		3	414	
P5.7	Run enable	0	Varies		0	407	
P5.8	Preset speed B0	0	Varies		0	419	
P5.9	Preset speed B1	0	Varies		0	420	
P5.10	Preset speed B2	0	Varies		0	421	
i P5.11	Ramp time 2 selection	0	Varies		0	408	
P5.12	Motor potentiometer up	0	Varies		0	418	

Table 26. Digital inputs.

Code	Parameter	Min	Max	Unit	Default	ID	Note
P5.13	Motor potentiometer down	0	Varies		0	417	
P5.14	Remote control place 2	0	Varies		0	425	
P5.15	Remote control place freq reference 2	0	Varies		0	343	
<i>i</i> P5.16	PID setpoint 2	0	Varies		0	1047	
<i>i</i> P5.17	Motor PreHeat ON	0	Varies		0	1044	

9.1.6 Analogue inputs (Control panel: Menu PAR → P6)

Table 27. Analogue inputs.

Code	Parameter	Min	Max	Unit	Default	ID	Note
P6.1	AI1 range	0	1		0	379	0 = 0 - 100% 1 = 20% - 100%
P6.2	AI1 Custom min	-100,00	100,00	%	0,00	380	
P6.3	AI1 Custom max	-100,00	300,00	%	100,0	381	
P6.4	AI1 filter time	0,0	10,0	s	0,1	378	
P6.5	AI2 range	0	1		0	390	As parameter P6.1
P6.6	AI2 Custom min	-100,00	100,00	%	0,00	391	As parameter P6.2
 P6.7	AI2 Custom max	-100,00	300,00	%	100,0	392	As parameter P6.3
 P6.8	AI2 filter time	0,0	10,0	s	0,1	389	As parameter P6.4
P6.9	AIE1 range	0	1		0	143	As parameter P6.1, hidden until an option board is connected.
P6.10	AIE1 Custom Min	-100,00	100,00	%	0,00	144	As parameter P6.2, hidden until an option board is connected.
P6.11	AIE1 Custom Max	-100,00	300,00	%	100,00	145	As parameter P6.3, hidden until an option board is connected.
P6.12	AIE1 Filter time	0,0	10,0	s	0,1	142	As parameter P6.4, hidden until an option board is connected.

9.1.7 Digital outputs (Control panel: Menu PAR → P7)

Table 28. Digital outputs.

Code	Parameter	Min	Max	Unit	Default	ID	Note
P7.1	RO1 signal selection	0	Varies		2	313	0 = Not used 1 = Ready 2 = Run 3 = Fault 4 = Fault Inverted 5 = Warning 6 = Reversed 7 = At Speed 8 = Motor regulator active 9 = FB Control Word.B13 10 = FB Control Word.B14 11 = FB Control Word.B15 12 = Output freq superv. 13 = Output torque superv. 14 = Unit temperature superv. 15 = Analogue input superv. 16 = Preset Speed Active 17 = External Brake ctrl 18 = Keypad control active 19 = I/O control active 20 = fire mode 21 = temperature supervision
P7.2	RO2 signal selection	0	Varies		3	314	As parameter 7.1
P7.3	DO1 signal selection	0	Varies		1	312	As parameter 7.1
P7.4	RO2 inversion	0	1		0	1588	0 = No inversion 1 = Inverted
P7.5	RO2 ON delay	0,00	320,00	s	0,00	460	



Table 28. Digital outputs.

Code	Parameter	Min	Max	Unit	Default	ID	Note
P7.6	RO2 OFF delay	0,00	320,00	s	0,00	461	
P7.7	RO1 inversion	0	1		0	1587	0 = No inversion 1 = Inverted
P7.8	RO1 ON delay	0	320,00	s	0,00	458	
P7.9	RO1 OFF delay	0	320,00	s	0,00	459	
P7.10	DOE1 signal selection	0	Varies		0	317	As parameter 7.1, hidden until an option board is connected.
P7.11	DOE2 signal selection	0	Varies		0	318	As parameter 7.1, hidden until an option board is connected.
P7.12	DOE3 signal selection	0	Varies		0	1386	As parameter 7.1, hidden until an option board is connected.
P7.13	DOE4 signal selection	0	Varies		0	1390	As parameter 7.1, hidden until an option board is connected.
P7.14	DOE5 signal selection	0	Varies		0	1391	As parameter 7.1, hidden until an option board is connected.
P7.15	DOE6 signal selection	0	Varies		0	1395	As parameter 7.1, hidden until an option board is connected.

9.1.8 Analogue outputs (Control panel: Menu PAR → P8)

Table 29. Analogue outputs.



Code	Parameter	Min	Max	Unit	Default	ID	Note
 P8.1	Analogue output signal selection	0	14		1	307	0 = Not used 1 = Output freq. (0...f _{max}) 2 = Output current (0...I _{nMotor}) 3 = Motor torque (0...T _{nMotor}) 4 = PID output (0...100%) 5 = Freq. refer. (0...f _{max}) 6 = Motor speed (0...n _{max}) 7 = Motor power (0...P _{nMotor}) 8 = Motor Voltage (0...U _{nMotor}) 9 = DC-link Voltage (0...1 000 V) 10 = Process Data In1 (0...10 000) 11 = Process Data In2 (0...10 000) 12 = Process Data In3 (0...10 000) 13 = Process Data In4 (0...10 000) 14 = Test 100%
 P8.2	Analogue output minimum	0	1		0	310	0 = 0 V / 0 mA 1 = 2 V / 4 mA
P8.3	Analogue output scaling	0,0	1000,0	%	100,0	311	
P8.4	Analogue output filter time	0,00	10,00	s	0,10	308	
P8.5	Analogue output E1 - signal selection	0	14		0	472	As parameter P8.1, hidden until an option board is connected
P8.6	Analogue output E1 - minimum	0	1		0	475	As parameter P8.2, hidden until an option board is connected
P8.7	Analogue output E1 - scaling	0,0	1000,0	%	100,0	476	As parameter P8.3, hidden until an option board is connected
P8.8	Analogue output E1 - filter time	0,00	10,00	s	0,10	473	As parameter P8.4, hidden until an option board is connected

Table 29. Analogue outputs.

Code	Parameter	Min	Max	Unit	Default	ID	Note
P8.9	Analogue output E2 - signal selection	0	14		0	479	As parameter P8.1, hidden until an option board is connected.
P8.10	Analogue output E2 - minimum	0	1		0	482	As parameter P8.2, hidden until an option board is connected.
P8.11	Analogue output E2 - scaling	0,0	1000,0	%	100,0	483	As parameter P8.3, hidden until an option board is connected.
P8.12	Analogue output E2 - filter time	0,00	10,00	s	0,10	480	As parameter P8.4, hidden until an option board is connected.

9.1.9 Fieldbus Data-Mapping (Control panel: Menu PAR → P9)

Table 30. Fieldbus Data-Mapping.

Code	Parameter	Min	Max	Unit	Default	ID	Note
<i>i</i> P9.1	FB Data Output 1 - selection	0	Varies		0	852	<i>0</i> = Frequency reference <i>1</i> = Output reference <i>2</i> = Motor speed <i>3</i> = Motor current <i>4</i> = Motor voltage <i>5</i> = Motor torque <i>6</i> = Motor power <i>7</i> = DC link voltage <i>8</i> = Active fault code <i>9</i> = AI1 <i>10</i> = AI2 <i>11</i> = Digital input state <i>12</i> = PID feedback value <i>13</i> = PID setpoint <i>14</i> = AIE1
P9.2	FB Data Output 2 - selection	0	Varies		1	853	
P9.3	FB Data Output 3 - selection	0	Varies		2	854	
P9.4	FB Data Output 4 - selection	0	Varies		4	855	
P9.5	FB Data Output 5 - selection	0	Varies		5	856	
P9.6	FB Data Output 6 - selection	0	Varies		3	857	
P9.7	FB Data Output 7 - selection	0	Varies		6	858	
P9.8	FB Data Output 8 - selection	0	Varies		7	859	
<i>i</i> P9.9	Aux CW Data In - selection	0	5		0	1167	<i>0</i> = Not used <i>1</i> = PDI1 <i>2</i> = PDI2 <i>3</i> = PDI3 <i>4</i> = PDI4 <i>5</i> = PDI5

9.1.10 Prohibited Frequencies (Control panel: Menu PAR → P10)

Table 31. Prohibited Frequencies.

Code	Parameter	Min	Max	Unit	Default	ID	Note
P10.1	Prohibit Frequency Range 1 Low Limit	0,00	P3.2	Hz	0,00	509	
P10.2	Prohibit Frequency Range 1 High Limit	0,00	P3.2	Hz	0,00	510	
P10.3	Prohibit Frequency Range 2 Low Limit	0,00	P3.2	Hz	0,00	511	
 P10.4	Prohibit Frequency Range 2 High Limit	0,00	P3.2	Hz	0,00	512	

9.1.11 Limit Supervisions (Control panel: Menu PAR → P11)

Table 32. Limit Supervisions.

Code	Parameter	Min	Max	Unit	Default	ID	Note
P11.1	Output frequency supervision function	0	2		0	315	0 = Not used 1 = Low limit 2 = High limit
P11.2	Output frequency supervision limit	0,00	P3.2	Hz	0,00	316	
P11.3	Torque supervision function	0	2		0	348	0 = Not used 1 = Low limit 2 = High limit
P11.4	Torque supervision limit	0,0	300,0	%	0,0	349	
P11.5	Unit Temperature Supervision	0	2		0	354	
P11.6	Unit Temperature Supervision Limit	-10	100	°C	40	355	
P11.7	Analogue input supervision signal	0	Varies		0	356	0 = AI1 1 = AI2 2 = AIE1
P11.8	AI superv ON level	0,00	100,0	%	80,00	357	
P11.9	AI superv OFF level	0,00	100,00	%	40,00	358	
P11.10	Temperature supervision input	1	7		1	1431	Binary-coded selection of signals to use for temperature supervision B0 = Temperature input 1 B1 = Temperature input 2 B2 = Temperature input 3  NOTE! Hidden until an option board is connected.
P11.11	Temperature supervision function	0	2		2	1432	As parameter 11.1, hidden until an option board is connected.

Table 32. Limit Supervisions.

Code	Parameter	Min	Max	Unit	Default	ID	Note
P11.12	Temperature supervision limit	-50,0/223,2	200,0/473,2		80,0	1433	Temperature supervision threshold, hidden until an option board is connected.

9.1.12 Protections (Control panel: Menu PAR → P12)



Table 33. Protections.

Code	Parameter	Min	Max	Unit	Default	ID	Note
P12.1	Analogue Input low fault	0	4		1	700	0 = No action 1 = Alarm 2 = Alarm, preset alarm frequency 3 = Fault: Stop function 4 = Fault: Coast
P12.2	Under voltage fault	1	2		2	727	1 = No response (no fault generated but drive still stops modulation) 2 = Fault: Coast
P12.3	Earth fault	0	3		2	703	0 = No action 1 = Alarm 2 = Fault: Stop function 3 = Fault: Coast
P12.4	Output Phase Fault	0	3		2	702	As parameter 12.3
 P12.5	Stall protection	0	3		0	709	As parameter 12.3
 P12.6	Under load protection	0	3		0	713	As parameter 12.3
 P12.7	Motor thermal protection	0	3		2	704	As parameter 12.3
 P12.8	Mtp: Ambient temperature	-20	100	°C	40	705	Environment temperature
 P12.9	Mtp: Zero speed cooling	0,0	150,0	%	40,0	706	Cooling in % at zero speed
 P12.10	Mtp: Thermal time constant	1	200	min	Varies	707	Thermal time constant of the engine
 P12.11	Stall Current	0,00	$2,0 \times I_{Nunit}$	A	I_{Nunit}	710	The engine is in stall, when the current exceeds this limit
 P12.12	Stall time	0,00	300,0	s	15,00	711	Blocking time

Table 33. Protections.

Code	Parameter	Min	Max	Unit	Default	ID	Note
P12.13	Stall frequency	0,10	320,0	Hz	25,00	712	
<i>i</i> P12.14	Field weakening load	10,0	150,0	%	50,0	714	
P12.15	Zero freq load	5,0	150,0	%	10,0	715	
<i>i</i> P12.16	Time limit	1,0	300,0	s	20,0	716	
P12.17	Analogue Input low fault delay	0,0	10,0	s	0,5	1430	
P12.18	External fault	0	3		2	701	As parameter 12.3
P12.19	Fieldbus fault	0	4		3	733	As parameter 12.1
P12.20	Preset alarm frequency	P3.1	P3.2	Hz	25,00	183	
P12.21	Parameters edit lock	0	1		0	819	<i>0</i> = Edit enabled 1 = Edit disabled
P12.22	Thermistor Fault	0	3		2	732	Hidden until option board supporting thermistor is connected: <i>0</i> = No action 1 = Alarm 2 = Fault: Stop function 3 = Fault: Coast
P12.23	FWD/REV conflict supervision	0	3		1	1463	As parameter 12.3
P12.24	Temperature fault	0	3		0	740	As parameter P12.3, hidden until an OPTBH board is connected.



Table 33. Protections.

Code	Parameter	Min	Max	Unit	Default	ID	Note
P12.25	Temperature fault input	1	7		1	739	Binary-coded selection of signals to use for alarm and fault triggering B0 = Temperature input 1 B1 = Temperature input 2 B2 = Temperature input 3  NOTE! Hidden until an OPTBH board is connected.
P12.26	Temperature fault mode	0	2		2	743	0 = Not used 1 = Low limit 2 = High limit
P12.27	Temperature fault limit	-50.0C/273.2 K	200,0/473,2		100,0	742	Temperature fault threshold, hidden until an OPTBH board is connected
 P12.28	Input phase fault	0	3		3	730	0 = No action 1 = Alarm 2 = Fault: Stop function 3 = Fault: Coast
 P12.29	Motor temperature memory mode	0	2		0	15521	0 = Disabled 1 = Constant mode 2 = Last value mode

	NOTE: These parameters are shown, when P16.2 = 0.
--	---

9.1.13 Fault autoreset parameters (Control panel: Menu PAR → P13)

Table 34. Fault autoreset parameters

Code	Parameter	Min	Max	Unit	Default	ID	Note
 P13.1	Automatic Reset	0	1		0	731	0 = Disabled 1 = Enable
P13.2	Wait time	0,10	10,00	s	0,50	717	
 P13.3	Trial time	0,00	60,00	s	30,00	718	
P13.4	Trials number	1	10		3	759	
P13.5	Restart Function	0	2		2	719	0 = Ramping 1 = Flying 2 = By start function



NOTE:

These parameters are shown, when P16.2 = 0.

9.1.14 PID control parameters (Control panel: Menu PAR → P14)

Table 35. PID control parameters.

Code	Parameter	Min	Max	Unit	Default	ID	Note
P14.1	Setpoint source selection	0	Varies		0	332	0 = Fixed setpoint % 1 = AI1 2 = AI2 3 = ProcessDataIn1 (0 -100%) 4 = ProcessDataIn2 (0 -100%) 5 = ProcessDataIn3 (0 -100%) 6 = ProcessDataIn4 (0 -100%) 7 = AIE1 8 = Temperature input 1 9 = Temperature input 2 10 = Temperature input 3
P14.2	Fixed setpoint 1	0,0	100,0		50,0	167	Fixed setpoint
P14.3	Fixed setpoint 2	0,0	100,0		50,0	168	Alternative fixed setpoint, selectable with DI
P14.4	Feedback source selection	0	Varies		1	334	0 = AI1 1 = AI2 2 = ProcessDataIn1 (0 -100%) 3 = ProcessDataIn2 (0 -100%) 4 = ProcessDataIn3 (0 -100%) 5 = ProcessDataIn4 (0 -100%) 6 = AI2-AI1 7 = AIE1 8 = Temperature input 1 9 = Temperature input 2 10 = Temperature input 3
P14.5	Feedback value minimum	0,0	50,0	%	0,0	336	Value at minimum signal
P14.6	Feedback value maximum	10,0	300,0	%	100,0	337	Value at maximum signal



Table 35. PID control parameters.

	Code	Parameter	Min	Max	Unit	Default	ID	Note
i	P14.7	P gain	0,0	1000,0	%	100,0	118	Proportional gain
i	P14.8	I time	0,00	320,00	s	10,0	119	Integrative time
i	P14.9	D time	0,00	10,00	s	0,00	132	Derivative time
	P14.10	Error inversion	0	1		0	340	0 = Direct 1 = Inverted
	P14.11	Sleep minimum frequency	0,00	P3.2	Hz	25,00	1016	Threshold for enter sleep
	P14.12	Sleep delay	0	3600	s	30	1017	Delay for enter sleep
i	P14.13	Wake up level	0,0	100,0	%	90	1018	Threshold for exit sleep
	P14.14	Sleep setpoint boost	0,0	50,0	%	10,0	1071	Referred to setpoint
	P14.15	Setpoint boost time	0	60	s	10	1072	Boost time after P14.12
	P14.16	Sleep maximum loss	0,0	50,0	%	5,0	1509	Referred to feedback value after boost
i	P14.17	Sleep loss check time	1	300	s	30	1510	After boost time P14.15
i	P14.18	Process unit source select	0	5		0	1513	0 = PID feedback value 1 = Output frequency 2 = Motor speed 3 = Motor torque 4 = Motor power 5 = Motor current
i	P14.19	Process unit decimal digits	0	3		1	1035	Decimals on display
i	P14.20	Process unit minimum value	0,0	P14.21		0,0	1033	Process min value
i	P14.21	Process unit maximum value	P14.20	3200,0		100,0	1034	Process max value

Table 35. PID control parameters.

Code	Parameter	Min	Max	Unit	Default	ID	Note
P14.22	Temperature min value	- 50 C / 223.2 K	P14.23		0,0	1706	Temperature min value for PID and frequency reference scale, hidden until an OPTBH board is connected
P14.23	Temperature max value	P14.2	200.0 C / 473.2 K		100,0	1707	Temperature max value for PID and frequency reference scale, hidden until an OPTBH board is connected



NOTE:

These parameters are shown, when P16.2 = 0.

9.1.15 Motor Pre-heat (Control panel: Menu PAR → P15)

Table 36. Motor Pre-heat.

Code	Parameter	Min	Max	Unit	Default	ID	Note
P15.1	PreHeat function	0	3-4 *		0	1225	0 = not used 1 = always in stop state 2 = controlled by digital input 3 = heatsink temperature limit 4 = external temperature limit
P15.2	PreHeat current	0	50% motor nominal current	A	0	1227	Motor pre heat current
P15.3	Heatsink temperature limit	-10	80	°C	40	1620	Heatsink temperature to stop pre heat
P15.4**	External temperature selection	0	7		1	1621	Selection of external temperature 0 = None of the temperature inputs are selected 1 = Temperature input 1 selected 2 = Temperature input 2 selected 3 = Temperature input 1 and 2 selected 4 = Temperature input 3 selected 5 = Temperature input 1 and 3 selected 6 = Temperature input 2 and 3 selected 7 = Temperature input 1, 2 and 3 selected
P15.5**	External temperature limit	-50.0***	200.0***	°C***	30.0	1622	External temperature to stop pre heat

* value 4 only if expansion OPTB2 is installed

** visible only if expansion OPTB2 is installed

*** unit and values depends on P16.3 Temperature unit

9.2 Easy usage menu (Control panel: Menu PAR → P16)

Table 37. Easy usage menu parameters.

Code	Parameter	Min	Max	Unit	Default	ID	Note
i P16.1	Active fire mode parameter group	0	3		0	540	0 = Disable fire mode parameter group wizard 1 = Enable fire mode parameter group wizard i NOTE! Visible only when Startup wizard is active.
P16.2	Parameter conceal	0	1		1	115	0 = All parameters visible 1 = Only quick setup parameter group visible
P16.3	Temperature unit	0	1		0	1197	0 = Celsius 1 = Kelvins i NOTE! Hidden until an OPTBH board is connected.
i P16.4	Application access word	0	30'000		0	2362	Input the right password could review parameter group 18.

9.3 Fire mode (Control panel: Menu PAR → P18)

Drive ignores all commands from keypad, fieldbus and PC tool and preset frequency when activated. If activated, alarm sign is shown on the keypad and warranty is void.

In order to enable the function, you need to set a password in the description field for parameter Fire Mode password. Please note, the NC (normally closed) type of this input!



NOTE:

THE WARRANTY IS VOID IF THIS FUNCTION IS ACTIVATED!
There is also a different password for test mode to be used for testing the Fire Mode without warranty becoming void.

Table 38. Fire mode.

Code	Parameter	Min	Max	Unit	Default	ID	Note
P18.1	Fire mode password	0	9999		0	1599	1234 = Test mode 1001 = Enable 1515 = Disable
P18.2	Fire mode frequency select	0	Varies		0	1617	0 = Fire mode preset 1 = Preset speed 0 2 = Keypad 3 = Fieldbus 4 = AI1 5 = AI2 6 = PID 7 = AI+AI2 8 = Motor potentiometer 9 = AIE1 10 = Temperature input 1 11 = Temperature input 2 12 = Temperature input 3  NOTE! This parameter will be locked when password for fire mode is activated (not in the test mode), and not only when fire mode input is set. To change the parameter you have to disable fire mode.

Table 38. Fire mode.

Code	Parameter	Min	Max	Unit	Default	ID	Note
P18.3	Fire mode: frequency preset	P3.1	P3.2	Hz	8.00	1598	Fire mode frequency preset i NOTE! This parameter will be locked when password for fire mode is activated (not in the test mode), and not only when fire mode input is set. To change the parameter you have to disable fire mode.
P18.4	Fire mode activation: close	0	Varies		6	1619	Digital input, if fire mode is enable or in test mode then when digital input is closed, fire mode will be active. As parameter 5.1 i NOTE! This parameter will be locked when password for fire mode is activated (not in the test mode), and not only when fire mode input is set. To change the parameter you have to disable fire mode.
P18.5	Fire mode activation: open	0	Varies		0	1596	Digital input, if fire mode is enable or in test mode then when digital input is open, fire mode will be active. As parameter 5.1 i NOTE! This parameter will be locked when password for fire mode is activated (not in the test mode), and not only when fire mode input is set. To change the parameter you have to disable fire mode.
P18.6	Fire mode: reverse	0	Varies		0	1618	Reverse command of rotation direction while running in fire mode. This DI has no effect in normal operation. As parameter 5.1 i NOTE! This parameter will be locked when password for fire mode is activated (not in the test mode), and not only when fire mode input is set. To change the parameter you have to disable fire mode.

9.3.1 System parameters

Table 39. System parameters.

Code	Parameter	Min	Max	Default	ID	Note
Software information (MENU SYS → V1)						
V1.1	API SW ID				2314	
V1.2	API SW version				835	
V1.3	Power SW ID				2315	
V1.4	Power SW version				834	
V1.5	Application ID				837	
V1.6	Application revision				838	
V1.7	System load				839	
When no OPTBH Board has been installed, the Modbus comm. Parameters are as follows						
V2.1	Communication status				808	Status of Modbus communication. Format: xx.yyy where xx = 0 - 64 (Number of error messages) and yyy = 0 - 999 (Number of good messages)
P2.2	Fieldbus protocol	0	1	0	809	0 = Not used 1 = Modbus used
P2.3	Slave address	1	255	1	810	
P2.4	Baud rate	0	8	5	811	0 = 300 1 = 600 2 = 1200 3 = 2400 4 = 4800 5 = 9600 6 = 19200 7 = 38400 8 = 57600

Table 39. System parameters.

Code	Parameter	Min	Max	Default	ID	Note
P2.6	Parity type	0	2	0	813	0 = None 1 = Even 2 = Odd The Stop Bit is 2-bit when Parity type is 0 = None; The Stop Bit is 1-bit when Parity type is 1 = Even or 2 = Odd
P2.7	Communication time out	0	255	10	814	0 = Not used 1 = 1 sec 2 = 2 secs, etc
P2.8	Reset communication status	0	1	0	815	
When OPTBH board has been installed, the comm.-parameters are as follows						
P2.1	Sensor 1 type	0	6	0	14072	0 = No Sensor 1 = PT100 2 = PT1000 3 = Ni1000 4 = KTY84 5 = 2 × PT100 6 = 3 × PT100
P2.2	Sensor 2 type	0	6	0	14073	0 = No Sensor 1 = PT100 2 = PT1000 3 = Ni1000 4 = KTY84 5 = 2 × PT100 6 = 3 × PT100

Table 39. System parameters.

Code	Parameter	Min	Max	Default	ID	Note
P2.3	Sensor 3 type	0	6	0	14074	0 = No Sensor 1 = PT100 2 = PT1000 3 = Ni1000 4 = KTY84 5 = 2 × PT100 6 = 3 × PT100
Other information						
V3.1	MWh counter				827	Million Watt Hour
V3.2	Power on days				828	
V3.3	Power on hours				829	
V3.4	Run counter: Days				840	
V3.5	Run counter: Hours				841	
V3.6	Fault counter				842	
V3.7	Panel parameter set status monitor					Hidden when connect with PC
P4.2	Restore factory defaults	0	1	0	831	1 = Restores factory defaults for all parameters
P4.3	Password	0000	9999	0000	832	
P4.4	Time for panel and lcd backlight active	0	99	5	833	0 = OFF 1...60 = 1...60 min >=60 = Always ON
P4.5	Save parameter set to panel	0	1	0		Hidden when connect with PC
P4.6	Restore parameter set from panel	0	1	0		Hidden when connect with PC
F5.x	Active Fault menu					
F6.x	Fault History menu					

10 Parameter description

On the next pages you can find the descriptions of certain parameters. The descriptions have been arranged according to parameter group and number.

10.1 Motor settings (Control panel: Menu PAR → P1)

Current limit

This parameter determines the maximum motor current from the frequency converter. To avoid motor overload, set this parameter according to the rated current of the motor. The current limit is equal to $(1.5 \times I_n)$ by default.

Motor control mode

With this parameter the user can select the motor control mode. The selections are:

0 = Frequency control:

Drive frequency reference is set to output frequency without slip compensation. Motor actual speed is finally defined by motor load.

1 = Open loop speed control:

Drive frequency reference is set to motor speed reference. The motor speed remains the same regardless of motor load. Slip is compensated.

U / f ratio

There are three selections for this parameter:

0 = Linear:

The voltage of the motor changes linearly with the frequency in the constant flux area from 0 Hz to the field weakening point (FWP) where the field weakening point voltage (FWP) is supplied to the motor. Linear U/f ratio should be used in constant torque applications. See the graphic below.

This default setting should be used if there is no special need for another setting.

1 = Square:

The voltage of the motor changes following a squared curve form with the frequency in the area from 0 Hz to the field weakening point where the field weakening point voltage is also supplied to the motor. The motor runs under magnetised below the field weakening point and produces less torque, power losses and electromechanical noise. Squared U/f ratio can be used in applications where torque demand of the load is proportional to the square of the speed, e.g. in centrifugal fans and pumps.

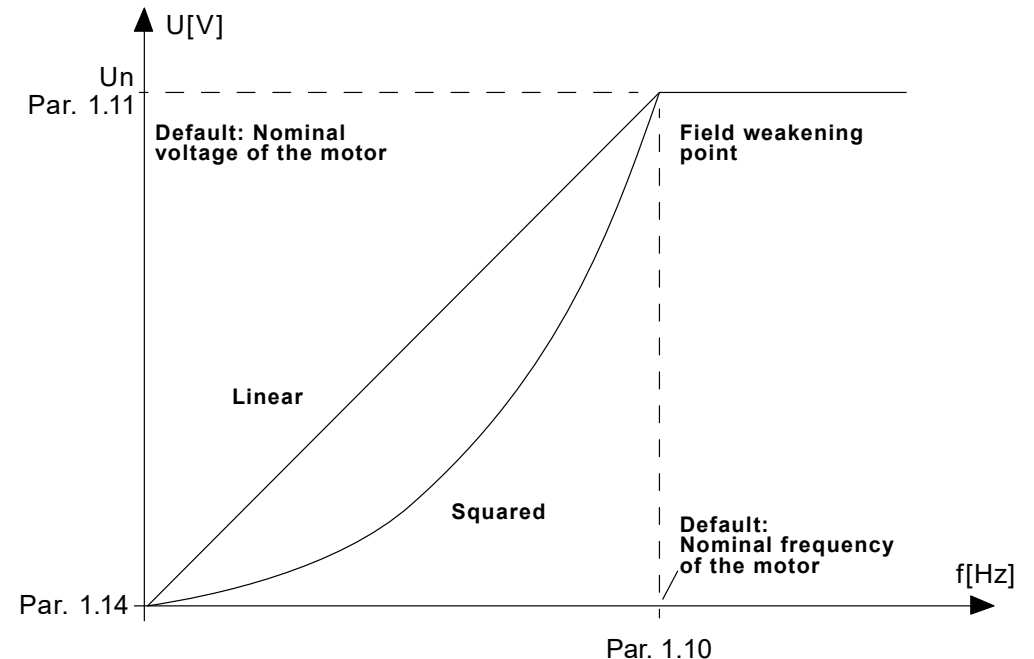

Fig. 43. Linear and squared change of motor voltage

2 = Programmable U/f curve:

The U/f curve can be programmed with three different points. Programmable U/f curve can be used if the other settings do not satisfy the needs of the application.

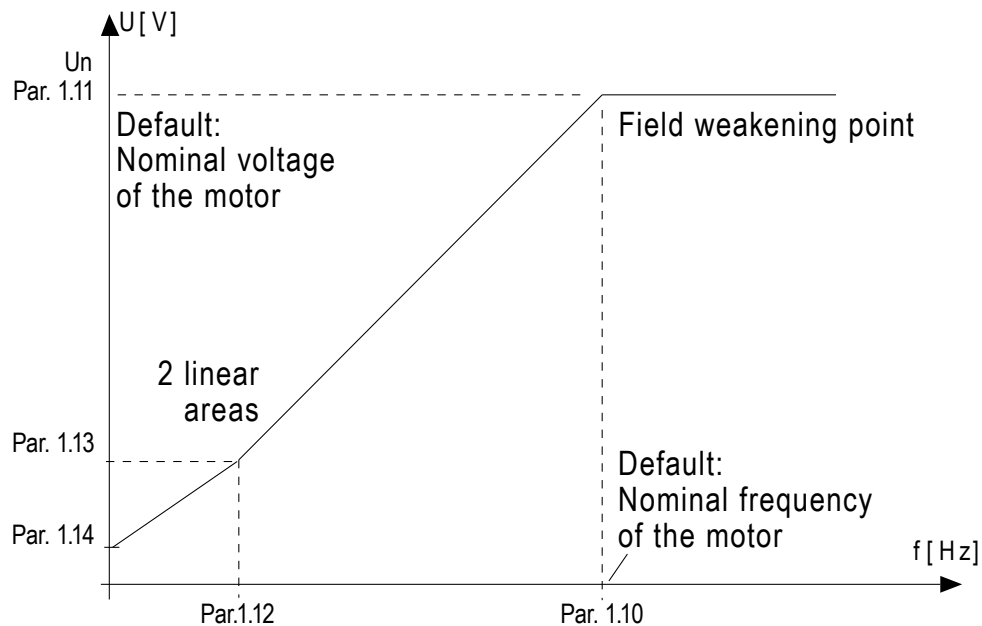

Fig. 44. Programmable U/f curve

Field weakening point

The field weakening point is the output frequency at which the output voltage reaches the value set with par.1.11.

Field weakening point voltage

Above the frequency at the field weakening point, the output voltage remains at the value set with this parameter. Below the frequency at the field weakening point, the output voltage depends on the setting of the U / f curve parameters. See „10 Parameter description“ on page 96 and „Fig. 43. Linear and squared change of motor voltage“ on page 96 and 125 and „Fig. 44. Programmable U/f curve“ on page 97.

When the parameters 1.1 and 1.2 (nominal voltage and nominal frequency of the motor) are set, the parameters 1.10 and 1.11 are automatically given the corresponding values. If you need different values for the field weakening point and the voltage, change these parameters after setting the parameters 1.1 and 1.2.

U/f middle point frequency

If the programmable U/f curve has been selected with the parameter 1.9, this parameter defines the middle point frequency of the curve. See „Fig. 44. Programmable U/f curve“ on page 97.

U/f middle point voltage

If the programmable U/f curve has been selected with the parameter 1.9, this parameter defines the middle point voltage of the curve. See „Fig. 44. Programmable U/f curve“ on page 97.

Zero frequency voltage



This parameter defines the zero frequency voltage of the curve see „Fig. 43. Linear and squared change of motor voltage“ on page 96 on page 96 and „Fig. 44. Programmable U/f curve“ on page 97.

Torque boost

When this parameter has been activated, the voltage to the motor changes automatically with high load torque which makes the motor produce sufficient torque to start and run at low frequencies. The voltage increase depends on the motor type and power. Automatic torque boost can be used in applications with high load torque, in conveyors.

0 = Disabled

1 = Enabled

	NOTE: In high torque - low speed applications - it is likely that the motor will overheat. If the motor has to run a prolonged time under these conditions, special attention must be paid to cooling the motor. Use external cooling for the motor if the temperature tends to rise too high.
	NOTE: The best performance can be reached by running motor identification, see „Motor identification“ on page 98

Switching frequency

Motor noise can be minimised using a high switching frequency. Increasing the switching frequency reduces the capacity of the frequency converter unit.

Switching frequency for HVAC232/402: 1.5...16 kHz.

Motor identification

0 = Not active

1 = Standstill identification

When **Standstill identification** is selected, the drive will perform an ID-run when it is started from selected control place. Drive has to be started within 20 seconds, otherwise identification is aborted.

The drive does not rotate the motor during **Standstill identification**. When ID run is ready the drive is stopped. Drive will start normally, when the next start command is given.

After end the identification, the drive need stop the start command. If control place is Keypad, user need press stop button. If control place is IO, user need put DI (Control signal) inactivate. If control place is fieldbus, user need set the control bit to 0.

The ID run improves the torque calculations and the automatic torque boost function. It will also result in a better slip compensation in speed control (more accurate RPM).

The parameters below will change after ID run successfully,

- a. P1.8 Motor control mode
- b. P1.9 U / f ratio
- c. P1.12 U / f mid point frequency
- d. P1.13 U / f mid point voltage
- e. P1.14 Zero freq voltage
- f. P1.17 Motor identification(1 → 0)
- g. P1.18 Rs voltage drop

	NOTE: The nameplate data of the motor has to be set BEFORE doing ID run.
---	--

Overvoltage controller

0 = Disabled

1 = Enabled, Standard mode (Minor adjustments of OP frequency are made)

2 = Enabled, Shock load mode (Controller adjusts OP freq. up to max. freq.)

Undervoltage controller

0 = Disable

1 = Enable

These parameters allow the under-/overvoltage controllers to be switched out of operation. This may be useful, for example, if the mains supply voltage varies more than -15% to $+10\%$ and the application will not tolerate this over-/undervoltage. In this case, the regulator controls the output frequency taking the supply fluctuations into account.

When a value other than 0 is selected also the Closed Loop overvoltage controller becomes active (in Multi-Purpose Control application).



NOTE:

Over-/undervoltage trips may occur when controllers are switched out of operation.

Efficiency optimization

Energy optimization, the frequency converter search for the minimum current in order to save energy and lower motor noise.

0 = Disable

1 = Enable

I/f start enable

The I/f Start function is typically used with permanent magnet motors (PM) to start the motor with constant current control. This is useful with high power motors in which the resistance is low and the tuning of the U/f curve difficult.

Applying the I/f Start function may also prove useful in providing sufficient torque for the motor at start-up.

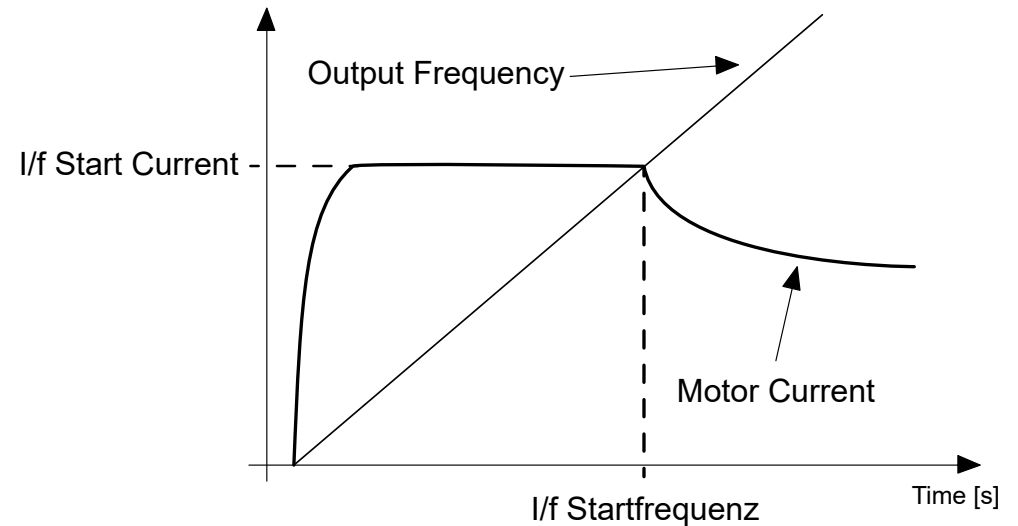

Fig. 45. I/f Start

I/f start frequency reference limit

Output frequency limit below which the defined I/f start current is fed to motor.

I/f start current reference

The current fed to the motor when the I/f start function is activated.

Voltage limiter enable

Voltage limiter function addresses problem with very high DC-link voltage ripple with 1-phase drives when fully loaded. Very high ripple in DC-link voltage will transform to high current and torque ripple, which can disturb some users. Voltage limiter function limits maximum output voltage to bottom of DC-voltage ripple. This reduces current and torque ripple, but decreases maximum output power since voltage is limited and more current is needed.

0 = disable,

1 = enable.

10.2 Start / stop setup (Control panel: Menu PAR → P2)

Remote control place selection

With this parameter, the user can select the active control place, frequency converter can be selected with P3.3/P3.12. The selections are:

- 0 = I/O terminal
- 1 = Fieldbus
- 2 = Keypad

	<p>NOTE:</p> <p>You can select control place by pressing Loc/Rem button or with par. 2.5(Local / Remote), P2.1 will have no effect in local mode.</p>
--	--

Local = Keyp ad is the control place
Remote=Control place determined by P2.1

Start function

The user can select two start functions for HVAC232/402 with this parameter:

0 = Ramp start

The frequency converter starts from 0 Hz and accelerates to the set frequency reference within the set acceleration time (See detailed description: ID103). (Load inertia, torque or starting friction may cause prolonged acceleration times).

1 = Flying start

The frequency converter is able to start into a running motor by applying small current pulses to motor and searching for the frequency corresponding to the speed the motor is running at. Searching starts from the maximum frequency towards the actual frequency until the correct value is detected. Thereafter, the output frequency will be increased/decreased to the set reference value according to the set acceleration/deceleration parameters.

Use this mode if the motor is coasting when the start command is given. With the flying start it is possible to start the motor from actual speed without forcing the speed to zero before ramping to reference.

Stop function

Two stop functions can be selected in this application:

0 = Coasting

The motor coasts to a halt without control from the frequency converter after the Stop command.

1 = Ramping

After the Stop command, the speed of the motor is decelerated according to the set deceleration parameters.

If the regenerated energy is high it maybe necessary to use an external braking resistor for to be able to decelerate the motor in acceptable time.

I/O start stop logic

Values 0..4 offer possibilities to control the starting and stopping of the AC drive with digital signal connected to digital inputs. CS = Control signal.

The selections including the text 'edge' shall be used to exclude the possibility of an unintentional start when, for example, power is connected, re-connected after a power failure, after a fault reset, after the drive is stopped by Run Enable (Run Enable = False) or when the control place is changed to I/O control. **The Start / Stop contact must be opened before the motor can be started.**

I/O stop logic uses accurate stop mode. Accurate stop mode is that the stop time is fixed from falling edge of DI to power stopping the drive.

Table 40.

Selection number	Selection name	Note
0	CS1:Forward CS2:Backward	The functions take place when the contacts are closed.

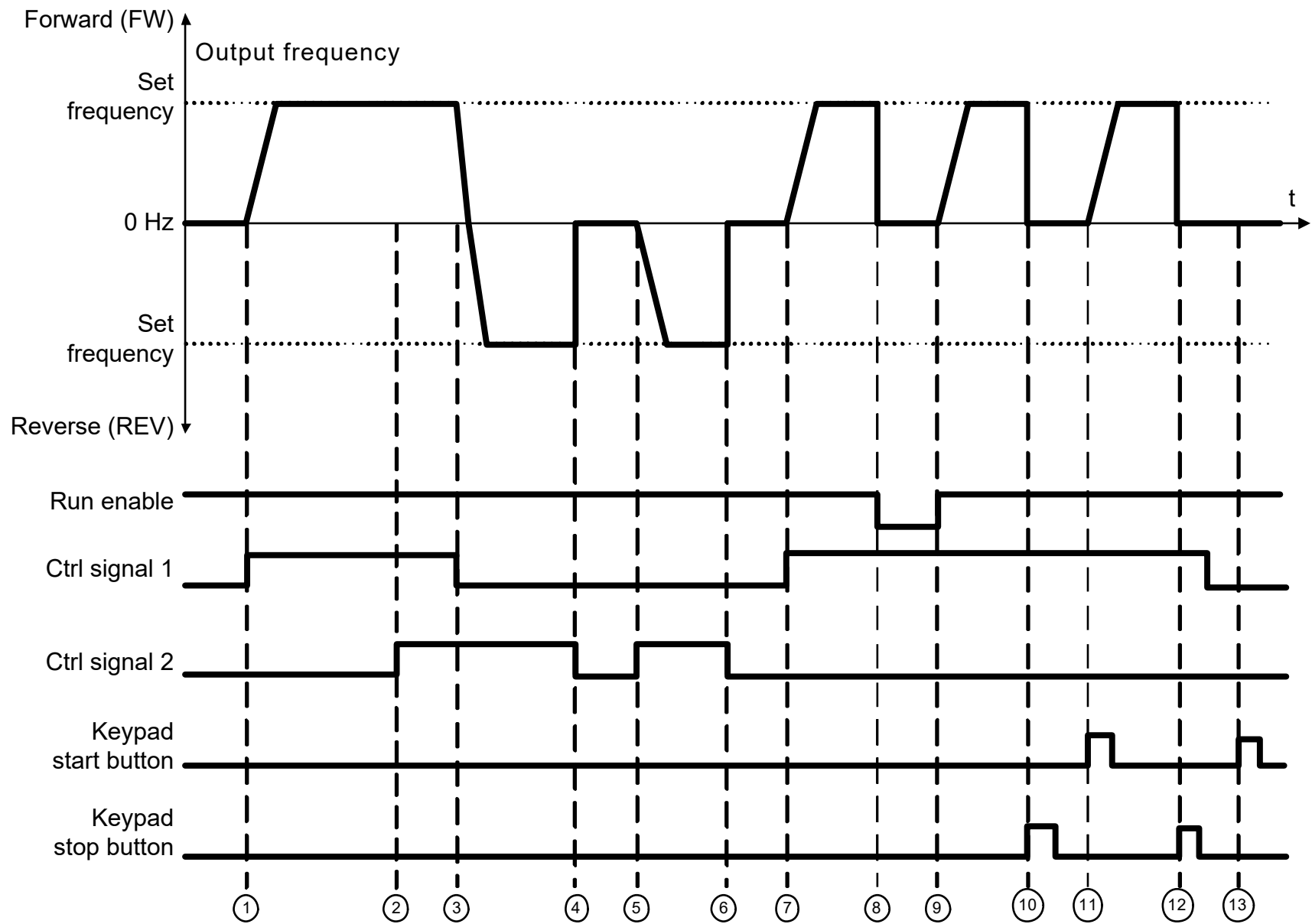

Fig. 46. Start/Stop logic, selection 0

Table 41.

Explanations			
1	Control signal (CS) 1 activates causing the output frequency to rise. The motor runs forward.	8	Run enable signal is not active what prevents the drive from starting (not ready) a digital input has been configured on par. 5.7
2	If start forward signal [CS1] and start reverse signal [CS2] are active simultaneously, there is alarm 55 Conflict FWD/REW.	9	Run enable signal is active, which causes the frequency to rise towards the set frequency because CS1 is still active.
3	CS1 is inactivated which caused the direction to start changing (FWD to REV) because CS2 is still active, and alarm 55 disappears.	10	Keypad stop button is pressed and the frequency output drops to 0 Hz. (This signal only works if Par. 2.7 [Keypad stop button] = 1)
4	CS2 is inactivated and the frequency drops to 0 Hz.	11	The drive starts through pushing the Start button on the keypad.
5	CS2 activates again causing the motor to accelerate (REV) towards the set frequency.	12	The keypad stop button is pushed again to stop the drive. (This signal only works if Par. 2.7 [Keypad stop button] = 1)
6	CS2 inactivates and the frequency output drops to 0 Hz.	13	The attempt to start the drive through pushing the Start button is not successful because CS1 is inactive.
7	CS1 activates and the motor accelerates (FWD) towards the set frequency.		

Table 42.

Selection number	Selection name	Note
1	CS1: Forward(edge) CS2: Inverted stop	

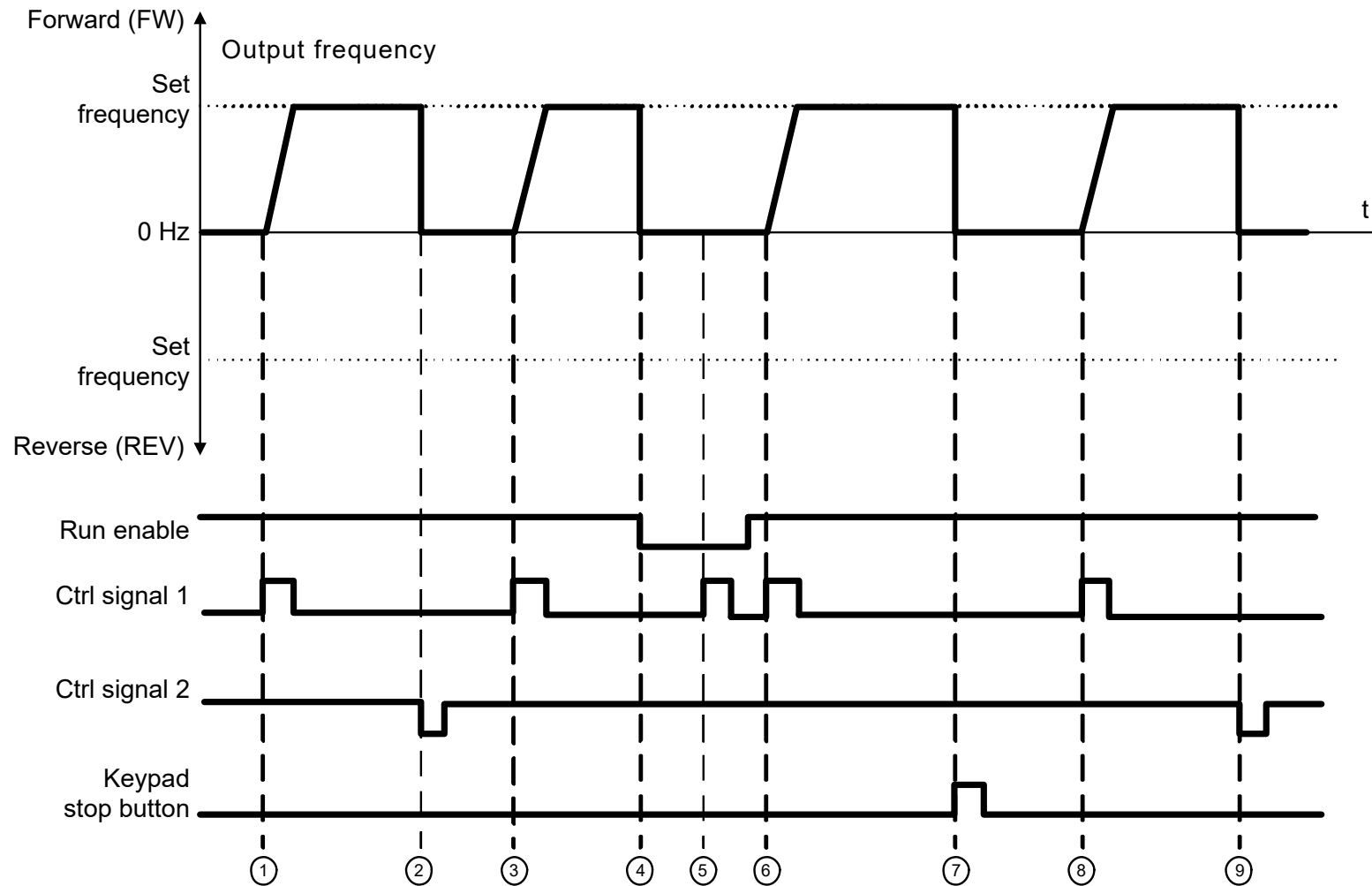

Fig. 47. Start/Stop logic, selection 1

Table 43.

Explanations			
1	Control signal (CS) 1 has been activated causing the output frequency to rise. The motor runs forward.	6	CS1 has been activated and the motor accelerates (FWD) towards the set frequency because the Run enable signal has been set to TRUE.
2	CS2 has been inactivated causing the frequency to drop to 0 Hz.	7	Keypad stop button is pressed and the frequency fed to the motor drops to 0.(This signal only works if Par.2.7 [Keypad stop button] = 1)
3	CS1 has been activated causing the output frequency to rise again. The motor runs forward.	8	CS1 has been activated causing the output frequency to rise again. The motor runs forward.
4	Run enable signal is set to FALSE, which drops the frequency to 0 Hz. The run enable signal is configured with par. 3.5.1.10	9	CS2 has been inactivated causing the frequency to drop to 0 Hz.
5	Start attempt with CS1 is not successful because Run enable signal is still FALSE.		

Table 44.

Selection number	Selection name	Note
2	CS1: Forward(edge) CS2: Backward(edge)	Shall be used to exclude the possibility of an unintentional start. The Start / Stop contact must be opened before the motor can be restarted.

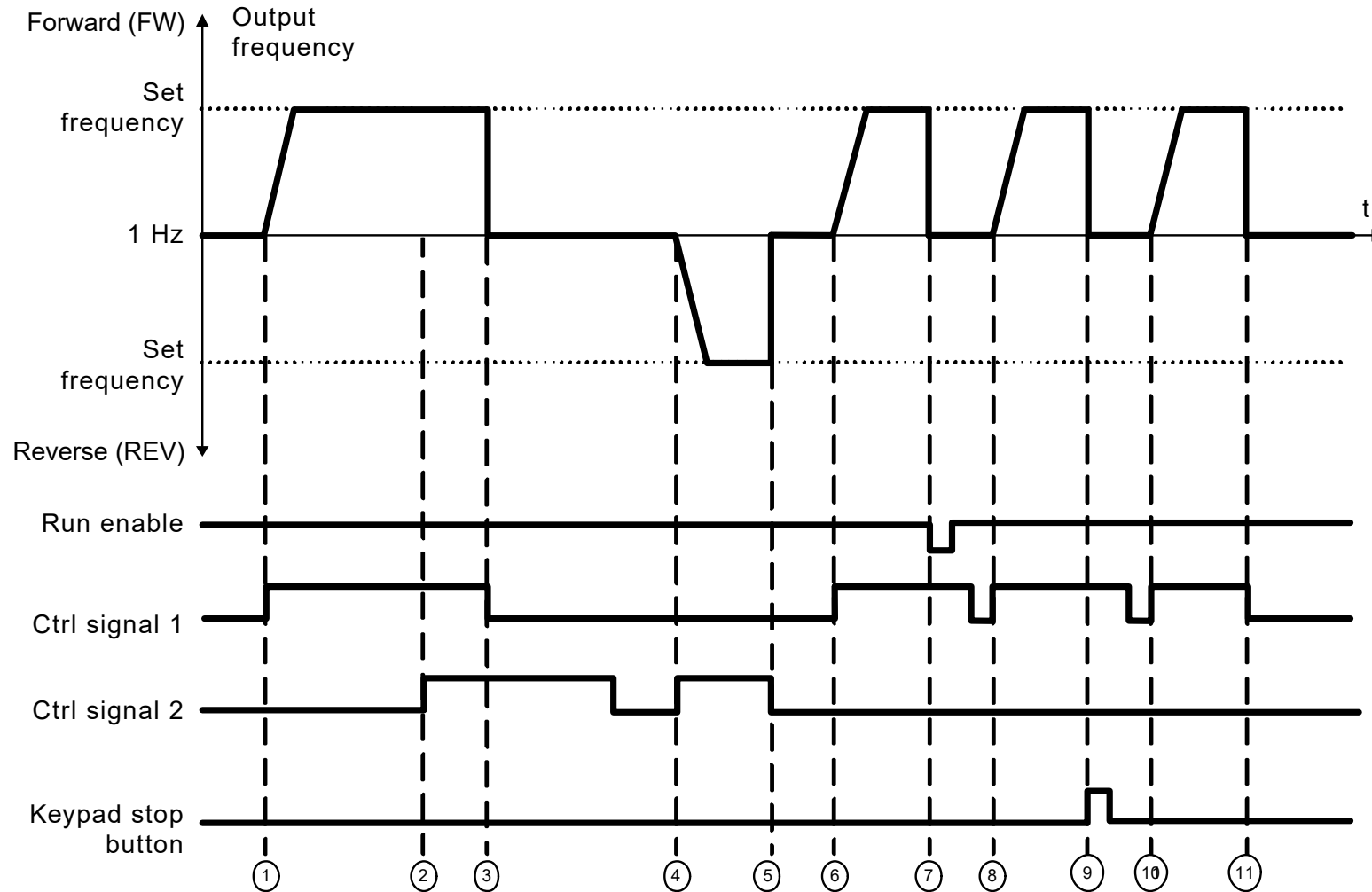

Fig. 48. Start/Stop logic, selection 2

Table 45.

Explanations			
1	Control signal (CS) 1 has been activated causing the output frequency to rise. The motor runs forward.	7	Run enable signal is set to FALSE, which drops the frequency to 0 Hz. The run enable signal is configured with par. 3.5.1.10
2	If start forward signal [CS1] and start reverse signal [CS2] are active simultaneously, there is alarm 55 in LCD panel when P13.23 FWD/REV conflict supervision=1.	8	CS1 has been activated and the motor accelerates (FWD) towards the set frequency because the Run enable signal has been set to TRUE.
3	CS1 has been inactivated the motor is still stopped though CS2 is still active, and alarm 55 should be disappeared in a while time.	9	Keypad stop button is pressed and the frequency fed to the motor drops to 0 Hz. (This signal only works if Par.2.7 [Keypad stop button] = 1)
4	CS2 has been activated again causing the motor to accelerate (REV) towards the set frequency.	10	CS1 is opened and closed again which causes the motor to start.
5	CS2 inactivates and the frequency fed to the motor drops to 0 Hz.	11	CS1 has been inactivated and the frequency fed to the motor drops to 0 Hz.
6	CS1 has been activated and the motor accelerates (FWD) towards the set frequency.		

Table 46.

Selection number	Selection name	Note
3	CS1: Start CS2: Reverse	

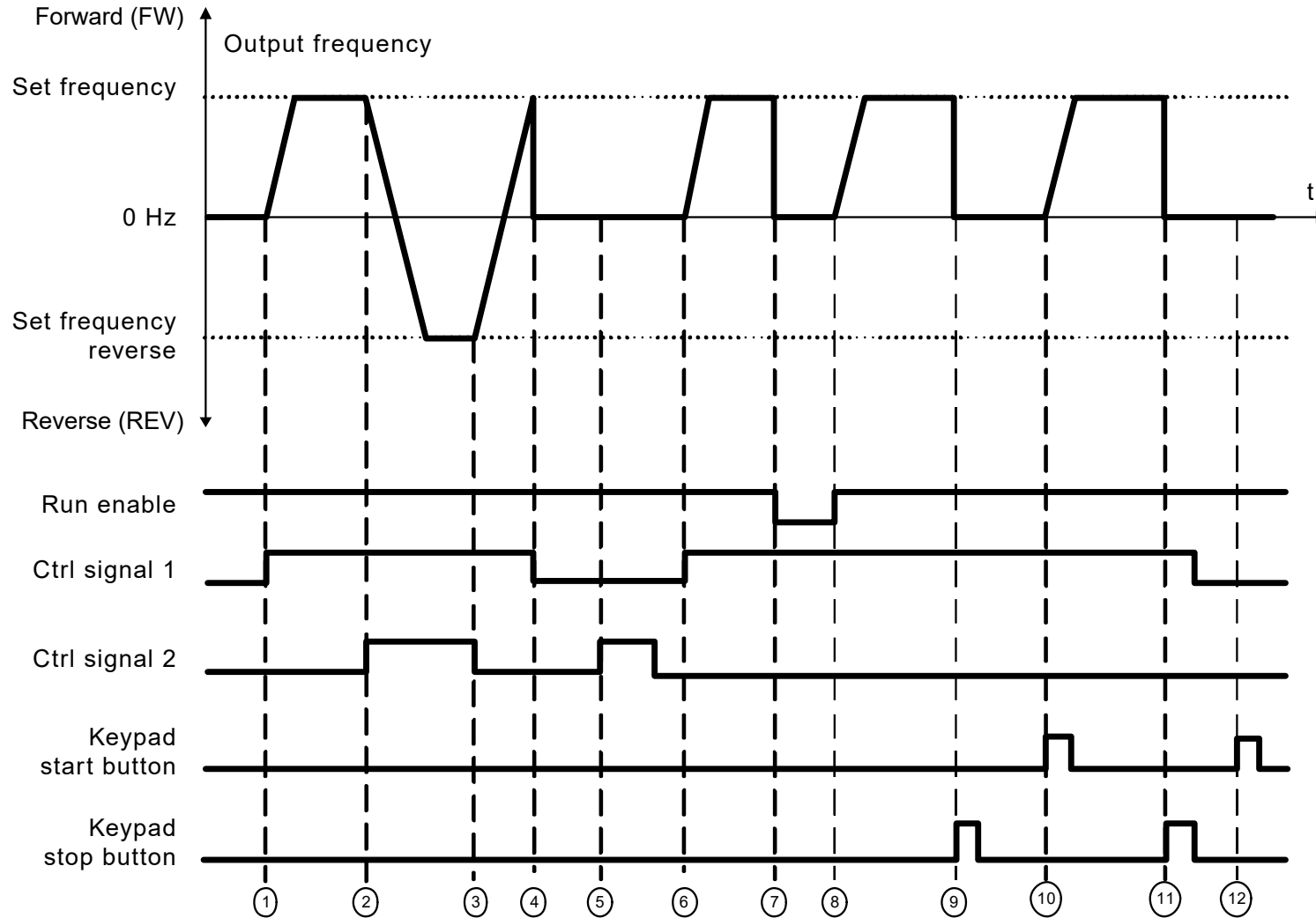

Fig. 49. Start/Stop logic, selection 3

Table 47.

Explanations			
1	Control signal (CS) 1 has been activated causing the output frequency to rise. The motor runs forward.	7	Run enable signal is set to FALSE, which drops the frequency to 0 Hz. The run enable signal is configured with par. 3.5.1.10.
2	CS2 has been activated which causes the direction to start changing (FWD to REV).	8	Run enable signal is set to TRUE, which causes the frequency to rise towards the set frequency because CS1 is still active.
3	CS2 has been inactivated which causes the direction to start changing (REV to FWD) because CS1 is still active.	9	Keypad stop button is pressed and the frequency fed to the motor drops to 0 Hz. (This signal only works if Par.2.7 [Keypad stop button] = 1)
4	Also CS1 has been inactivated and the frequency drops to 0 Hz.	10	The drive starts through pushing the Start button on the keypad.
5	Despite the activation of CS2,the motor does not start because CS1 is inactive.	11	The drive is stopped again with the Stop button on the Keypad.
6	CS1 has been activated causing the output frequency to rise again. The motor runs forward because CS2 is inactive.	12	The attempt to start the drive through pushing the Start button is not successful because CS1 is inactive.

Table 48.

Selection number	Selection name	Note
4	CS1: Start(edge) CS2: Reverse	Shall be used to exclude the possibility of an unintentional start. The Start / Stop contact must be opened before the motor can be restarted.

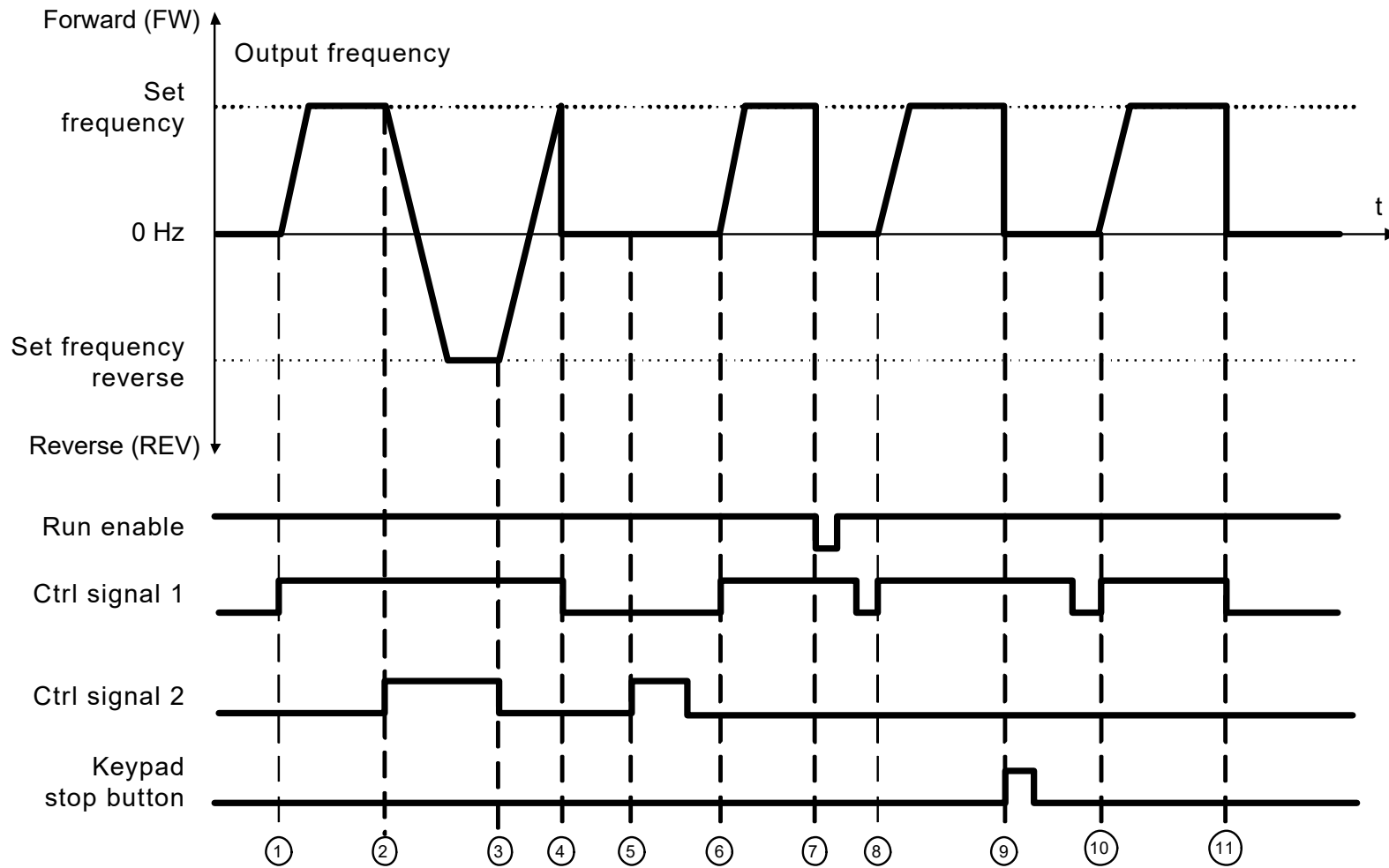

Fig. 50. Start/Stop logic, selection 4

Table 49.

Explanations			
1	Control signal (CS) 1 has been activated causing the output frequency to rise. The motor runs forward because CS2 is inactive.	7	Run enable signal is set to FALSE, which drops the frequency to 0 Hz. The run enable signal is configured with par. 5.7.
2	CS2 has been activated which causes the direction to start changing (FWD to REV).	8	Before a successful start can take place, CS1 must be opened and closed again.
3	CS2 has been inactivated which causes the direction to start changing (REV to FWD) because CS1 is still active.	9	Keypad stop button is pressed and the frequency fed to the motor drops to 0 Hz. (This signal only works if Par.2.7 [Keypad stop button] = 1)
4	Also CS1 has been inactivated and the frequency drops to 0 Hz.	10	Before a successful start can take place, CS1 must be opened and closed again.
5	Despite the activation of CS2, the motor does not start because CS1 is inactive.	11	CS1 has been inactivated and the frequency drops to 0 Hz.
6	CS1 has been activated causing the output frequency to rise again. The motor runs forward because CS2 is inactive.		

Local / remote

This parameter defines whether the control place of the drive is remote (I/O or FieldBus) or local.

0 = Remote Control

1 = Local Control

The priority order of selecting control place is

1. PC control from Honeywell live operation window
2. Loc / Rem button
3. Forced from I/O terminal

10.3 Frequency references (Control panel: Menu PAR → P3)

Remote control place frequency reference selection

It defines the selected frequency reference source when the drive is remote control. A second reference source is programmable in par. 3.12.

- 4. = Preset speed 0
- 5. = Keypad reference
- 6. = Fieldbus Reference
- 7. = AI1
- 8. = AI2
- 9. = PID 10.= AI1+AI2
- 11.= Motor potentiometer

Preset speeds 0 - 7

Preset speed 0 is used as frequency reference when P3.3 = 1.

Preset speeds 1 - 7 can be used to determine frequency references that are applied when appropriate combinations of digital inputs are activated. Preset speeds can be activated from digital inputs despite of the active control place.

Parameter values are automatically limited between the minimum and maximum frequencies. (Par. 3.1 and 3.2).

Table 50. Preset speeds 1 - 7

Speed	Preset speed B2	Preset speed B1	Preset speed B0
Preset speed 1			x
Preset speed 2		x	
Preset speed 3		x	x
Preset speed 4	x		
Preset speed 5	x		x
Preset speed 6	x	x	
Preset speed 7	x	x	x

Motor potentiometer ramp

Motor potentiometer reset

P3.13 is the speed variation ramp when motor potentiometer reference is increased or decreased.

P3.14 tells under which circumstances the potentiometers reference should be reset and start over from 0 Hz.

- 0 = No Reset
- 1 = Reset if stopped
- 2 = Reset if powered down

P5.12 and P5.13 sets which digital inputs increase and decrease the motor potentiometers reference.

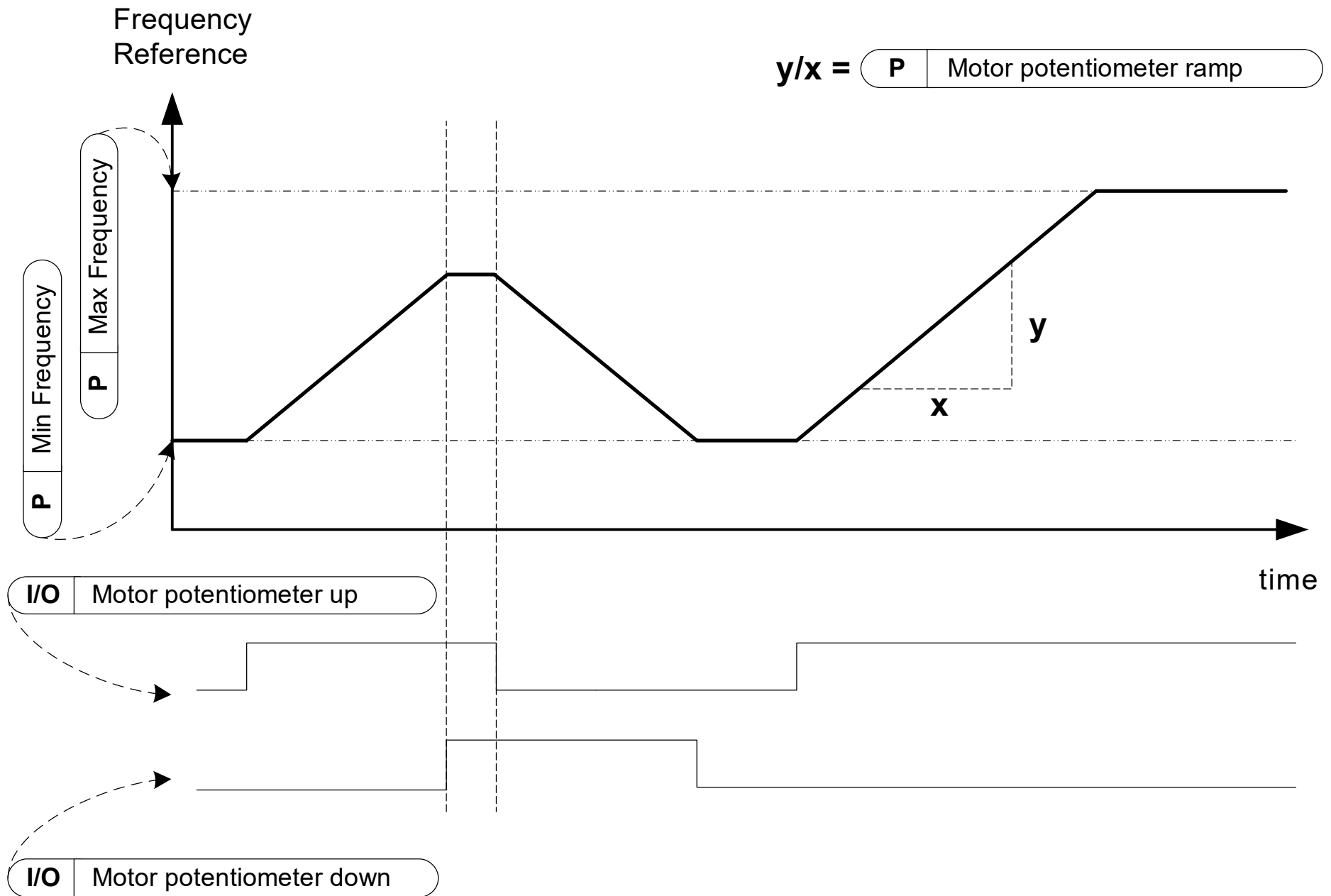

Fig. 51. The change of motor potentiometers reference

10.4 Ramps & brakes setup (Control panel: Menu PAR → P4)

Ramp S-shape

The start and end of the acceleration and deceleration ramp can be smoothed with this parameter. Setting value 0 gives a linear ramp shape which causes acceleration and deceleration to act immediately to the changes in the reference signal.

Setting value 0.1...10 seconds for this parameter produces an S-shaped acceleration/deceleration. The acceleration and deceleration times are determined with parameters 4.2 and 4.3.

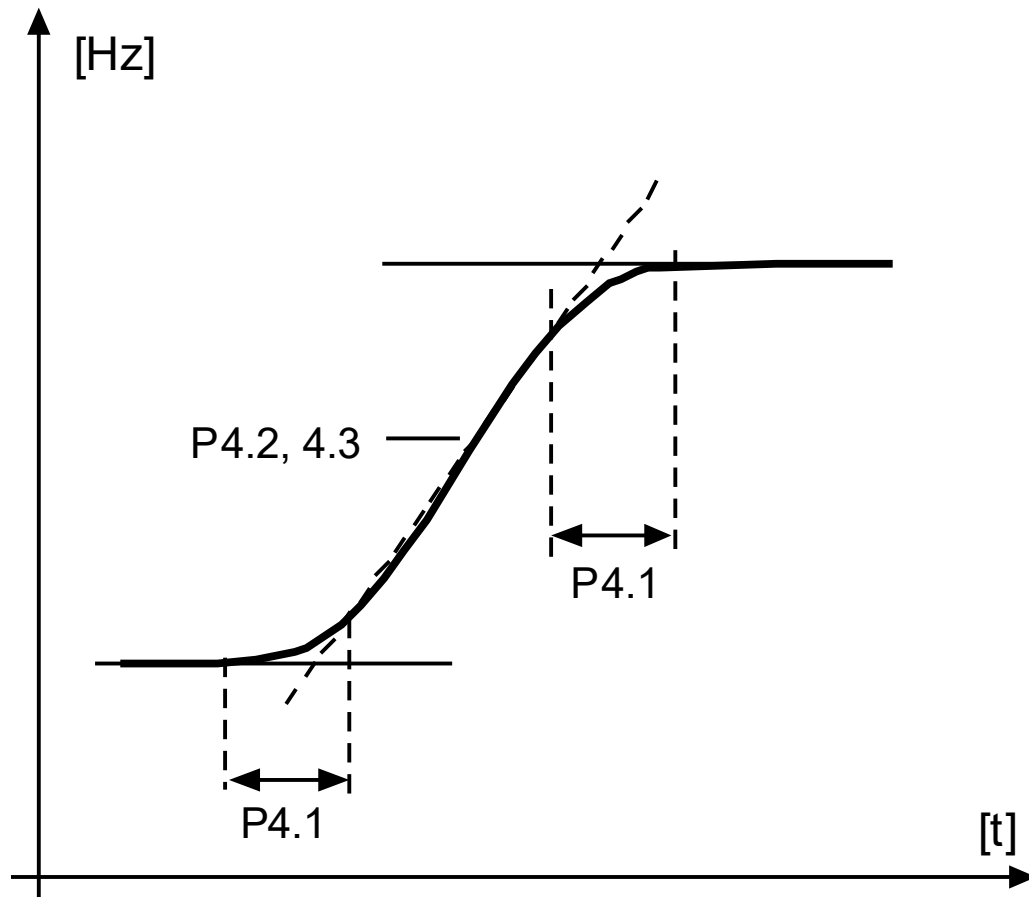

Fig. 52. S-shaped acceleration/deceleration

Acceleration time 1

Deceleration time 1

Ramp S-shape 2

Acceleration time 2

Deceleration time 2

These limits correspond to the time required for the output frequency to accelerate from the zero frequency to the set maximum frequency, or to decelerate from the set maximum frequency to zero frequency.

The user can set two different acceleration/deceleration time and set two different ramp s-shape for one application. The active set can be selected with the selected digital input (par. 5.11).

Flux braking

Instead of DC braking, flux braking is a useful form of braking with motors of max. 15 kW.

When braking is needed, the frequency is reduced and the flux in the motor is increased, which in turn increases the motor's capability to brake. Unlike DC braking, the motor speed remains controlled during braking.

- 0 = Off
- 1 = Deceleration
- 2 = Chopper
- 3 = Full Mode



NOTE:

Flux braking converts the energy into heat at the motor, and should be used intermittently to avoid motor damage.

Stop DC current time

Determines if braking is ON or OFF and the braking time of the DC-brake when the motor is stopping. The function of the DC-brake depends on the stop function, par. 2.3.

0 = DC brake is not active

>0 = DC brake is active and its function depends on the Stop function, (par. 2.3).
The DC braking time is determined with this parameter.

Par. 2.3 = 0 (Stop function = Coasting):

After the stop command, the motor coasts to a stop without control from the frequency converter.

With the DC injection, the motor can be electrically stopped in the shortest possible time, without using an optional external braking resistor.

The braking time is scaled by the frequency when the DC-braking starts. If the frequency is greater, or equal to the nominal frequency of the motor, the set value of parameter 4.10 determines the braking time. When the frequency is 10% of the nominal, the braking time is 10% of the set value of parameter 4.10.

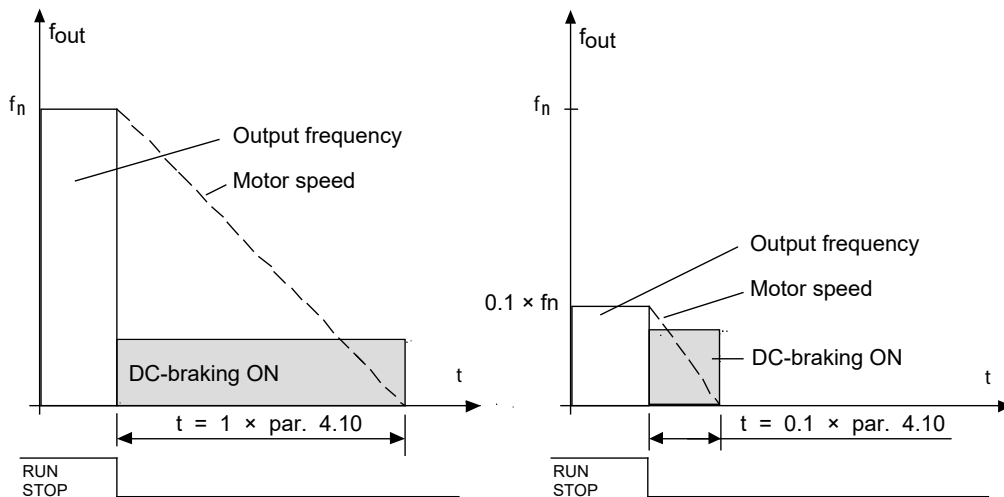

Fig. 53. DC-braking time when Stop mode = Coasting

Par. 2.3 = 1 (Stop function = Ramp):

After the Stop command, the speed of the motor is reduced according to the set deceleration parameters, if the inertia of the motor and load allows that, to the speed defined with parameter 4.11, where the DC-braking starts.

The braking time is defined with parameter 4.10. See „Fig. 51. The change of motor potentiometers reference“ on page 113.

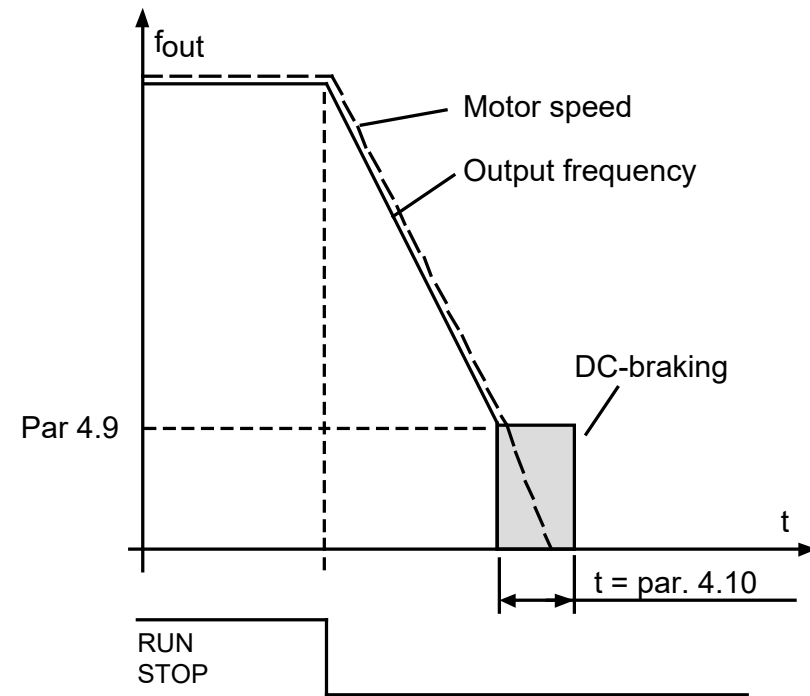

Fig. 54. DC-braking time when Stop mode = Ramp

Stop DC current frequency if stop function is ramping

It is the output frequency at which the DC-braking is applied. See picture above.

Start DC current time

DC-brake is activated when the start command is given. This parameter defines the time for how long DC current is fed to motor before acceleration starts. After the brake is released, the output frequency increases according to the set start function by par. 2.2.

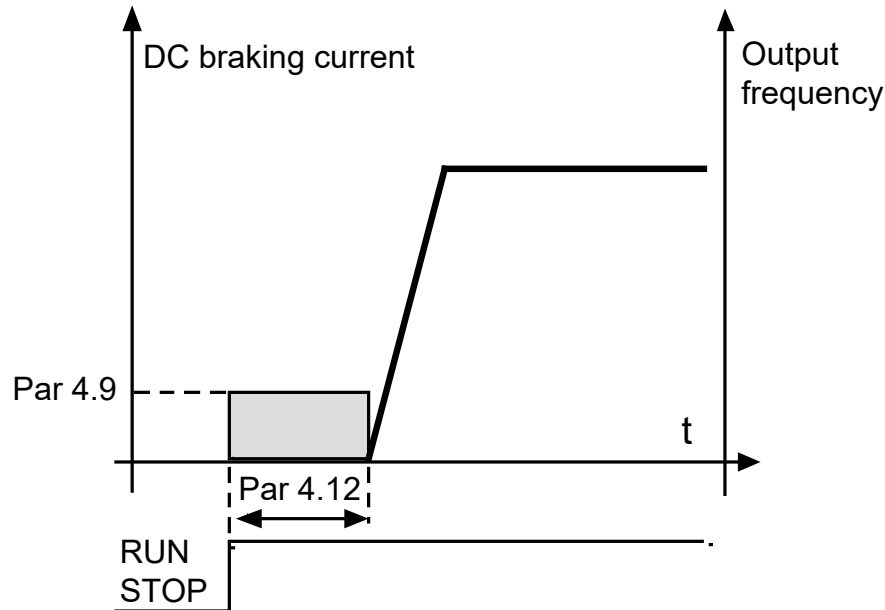

Fig. 55. DC braking time at start

External brake: Open delay

External brake: Open frequency limit

External brake: Close frequency limit

External brake: Close frequency limit in reverse

External brake: Open / close current limit

External brake control is used for controlling a mechanical brake on the motor by digital / relay output by selecting value 17 for parameters P8.1, P8.2 or P8.3. Brake is closed while relay is open and vice versa.

Opening brake conditions:

There are three different conditions for opening the brake, all must be true, if used.

1. The Open frequency limit (P4.16) must be reached.
2. When the Opening frequency limit has been reached the Open delay (P4.15) must also elapse. Note! The output frequency is held at the Open frequency limit until this.
3. When the two previous conditions are reached. The brake will open if the output current is higher than the current limit (P4.19).

Notice that any of the previous conditions can be left out by setting their values to zero.

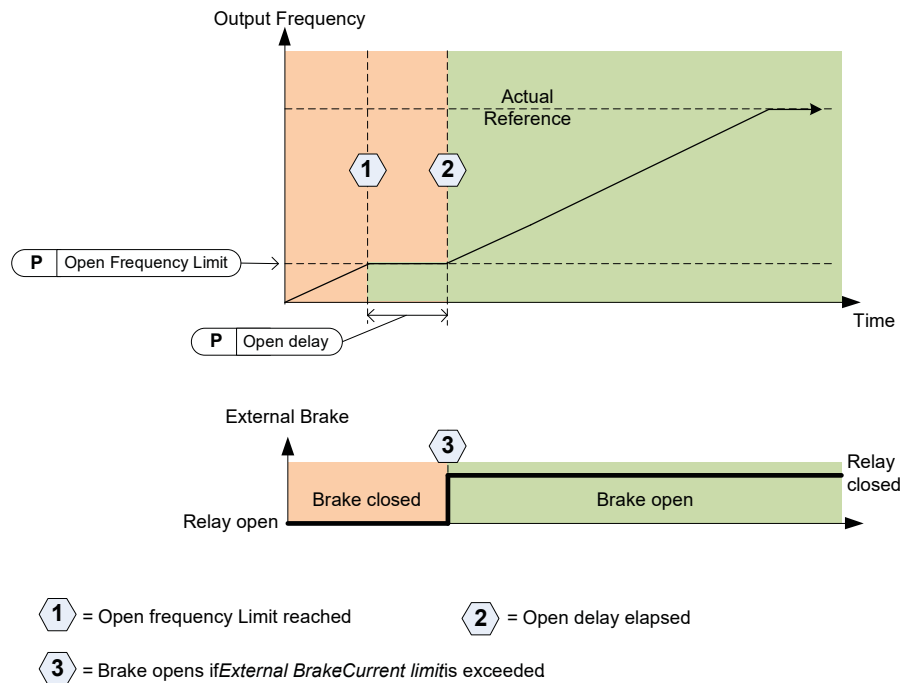

Fig. 56. Starting / opening sequence with external brake

Closing brake conditions:

There are 2 conditions for closing the brake again. It's enough that one is true for the brake to close.

1. If there is no run command active and output frequency goes below Close frequency limit (P4.17) or Close frequency limit in reverse (P4.18), depending on direction of rotation.

OR

2. Output current has gone below Current limit (P4.19)

10.5 Digital inputs (Control panel: Menu PAR → P5)

These parameters are programmed using the Closing brake conditions: FTT-method (Function To Terminal), where you have a fixed input or output that you define a certain function for. You can also define more than one function to a digital input, e.g. Start signal 1 and Preset Speed B1 to DI1.

The selections for these parameters are:

- 0 = Not used
- 1 = DI1
- 2 = DI2
- 3 = DI3
- 4 = DI4
- 5 = DI5
- 6 = DI6

I/O ctrl signal 1

I/O ctrl signal 2

P5.1 and P5.2 : See P2.4 (I/O start stop logic) for function

Reverse

The digital input only active when P2.4 (I/O start stop logic)=1.

The motor will run in reverse when the rising edge of P5.3 is happened.

Ramp time 2 selection

Contact open: Acceleration / Deceleration time 1 and Ramp S-shape selected

Contact closed: Acceleration / Deceleration time 2 and Ramp S-shape2 selected

Set Acceleration / Deceleration time with parameters 4.2 and 4.3 and the alternative Acceleration / Deceleration time with 4.4 and 4.5.

Set Ramp S-shape with Par. 4.1 and the alternative Ramp S-shape2 with Par. 4.4

PID setpoint 2

Digital input high activates setpoint 2 (P14.3), when P14.1=0.

Motor preheat active

Digital input high activates the Motor preheat function (if P16.1 = 2) which feeds DC-Current to the motor in stop state.

10.6 Analogue inputs

(Control panel: Menu PAR → P6)

AI1 Custom maximum

AI1 filter time

AI2 Custom minimum

AI2 Custom maximum

These parameters set the analogue input signal for any input signal span from minimum to maximum.

AI2 filter time

This parameter, given a value greater than 0, activates the function that filters out disturbances from the incoming analogue signal.

Long filtering time makes the regulation response slower.

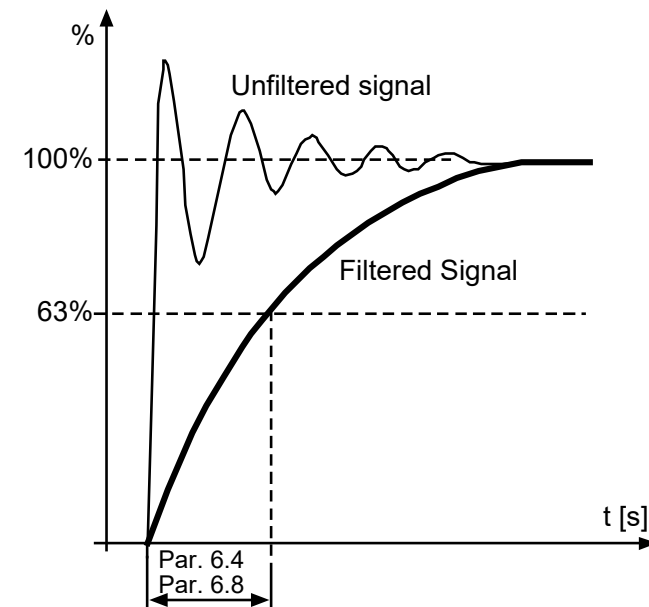

Fig. 57. AI1 and AI2 signal filtering

10.7 Digital outputs (Control panel: Menu PAR → P7)

RO1 signal selection

RO2 signal selection

DO1 signal selection

Table 51. Outputs signals via RO1, RO2 and DO1

Setting	Signal content
0 = Not used	Output is not in operation.
1 = Ready	The frequency converter is ready to operate.
2 = Run	The frequency converter operates (motor is running).
3 = Fault	A fault trip has occurred.
4 = Fault inverted	A fault trip has not occurred.
5 = Warning	A warning is active.
6 = Reversed	The reverse command has been selected, output frequency to the motor is negative.
7 = At speed	The output frequency has reached the set reference.
8 = Motor regulator active	All motor monitoring functions are activated (e.g., over current regulator, over voltage regulator, under voltage regulator, etc.)
9 = FB Control Word.B13	Output can be controlled with B13 in the fieldbus control word.
10 = FB Control Word.B14	Output can be controlled with B14 in the fieldbus control word.
11 = FB Control Word.B15	Output can be controlled with B15 in the fieldbus control word.

Setting	Signal content
12 = Output frequency superv.	Output frequency is over / under the limits, set with parameters P11.1 and P11.2.
13 = Output torque superv.	Motor torque is over/under the limit, set with parameter P11.3 and P11.4
14 = Unit temperature superv.	Unit temperature is over / under the limits, set with parameters P11.5 and P11.6.
15 = Analogue input superv.	Analogue inputs set with parameter P11.7 is over / under the limits, set in P11.8 and P11.9.
16 = Preset Speed Active	Each of preset speeds are activated.
17 = External Brake control	External Brake control. Closed = Brake open, Open = Brake closed.
18 = Keypad control active	Keypad is set as the current control place.
19 = I/O control active	I/O is set as the current control place.
20 = Fire mode active	
21 = Temperature supervision	

10.8 Analogue outputs (Control panel: Menu PAR → P8)

Analogue output signal selection

- 0** = Not used
- 1** = Output frequency ($0 - f_{max}$)
- 2** = Output current ($0 - I_{nMotor}$)
- 3** = Motor torque ($0 - T_{nMotor}$)
- 4** = PID output ($0 - 100\%$)
- 5** = Frequency reference ($0 - f_{max}$)
- 6** = Motor speed ($0 - n_{max}$)
- 7** = Motor power ($0 - P_{nMotor}$)
- 8** = Voltage ($0 - U_{nMotor}$)
- 9** = DC-link Voltage ($0 - 1000\text{ V}$)
- 10** = Process Data In1 ($0 - 10000$)
- 11** = Process Data In2 ($0 - 10000$)
- 12** = Process Data In3 ($0 - 10000$)
- 13** = Process Data In4 ($0 - 10000$)
- 14** = Test 100%

Analogue output minimum

0 = $0\text{ V} / 0\text{ mA}$

1 = $2\text{ V} / 4\text{ mA}$

10.9 Fieldbus Data-Mapping (Control panel: Menu PAR → P9)

FB data out 1 selection

Parameter couples read only variables to output process data1.

- 0** = Frequency reference
- 1** = Output reference
- 2** = Motor speed
- 3** = Motor current
- 4** = Motor voltage
- 5** = Motor torque
- 6** = Motor power
- 7** = DC link voltage
- 8** = Active faultcode
- 9** = Analogue AI1
- 10** = Analogue AI2
- 11** = Digital input state
- 12** = PID feedback value
- 13** = PID setpoint

Aux cw data in selection

Parameter defines the input process data coupled to Aux Control Word.

0 = Not used

1 = PDI1

2 = PDI2

3 = PDI3

4 = PDI4

5 = PDI5

10.10 Prohibited Frequencies (Control panel: Menu PAR → P10)

Prohibit frequency range 1: Low limit

Prohibit frequency range 1: High limit

Prohibit frequency range 2: Low limit

Prohibit frequency range 2: High limit

Two skip frequency regions are available if there is a need to avoid certain frequencies because of e.g. mechanical resonance. In this case the actual frequency reference sent to the motor control will be kept out of these ranges according to the example below, where one range is in use.

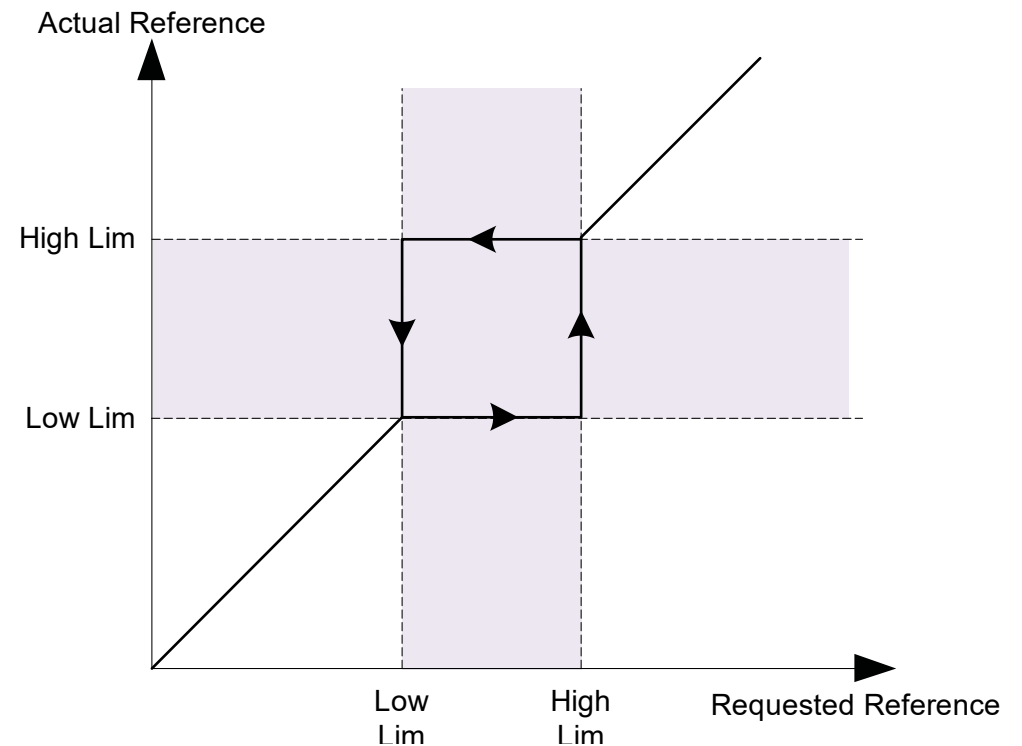

Fig. 58. Frequency Range

10.11 Protections (Control panel: Menu Par → P12)

Stall protection

0 = No action

1 = Alarm

2 = Fault, stop function

3 = Fault, coast

The motor stall protection protects the motor from short time overload situations such as one caused by a stalled shaft. The reaction time of the stall protection must be set shorter than that of motor thermal protection. The stall state is defined with two parameters, P12.11 (Stall current) and P12.13 (Stall frequency limit). If the current is higher than the set limit and the output frequency is lower than the set limit the stall state is true. There is actually no real indication of the shaft rotation. Stall protection is a type of over current protection.

Under load protection

0 = No action

1 = Alarm

2 = Fault, stop function

3 = Fault, coast „Stop function“ on page 119

The purpose of the motor underload protection is to ensure that there is load on the motor when the drive is running. If the motor loses its load there might be a problem in the process, e.g. a broken belt or a dry pump.

Motor underload protection can be adjusted by setting the underload curve with parameters P12.14 (Underload protection: Field weakening area load) and P12.15 (Underload protection: Zero frequency load), see the figure below. The underload curve is a squared curve set between the zero frequency and the field weakening point. The protection is not active below 5 Hz (the underload time counter is stopped).

The torque values for setting the underload curve are set in percentage which refers to the nominal torque of the motor. The motor's name plate data, parameter motor nominal current and the drive's nominal current I_L are used to find the scaling ratio for the internal torque value. If other than nominal motor is used with the drive, the accuracy of the torque calculation decreases.

The default parameter value of the underload protection time limit is 20 seconds, which is the maximum time allowed for an underload state to exist before causing a trip according to this parameter.

Underload curve at
field weakening point,
P12.14 (default) = 50%

Underload curve at
frequency zero load,
P12.15
(default) = 10%

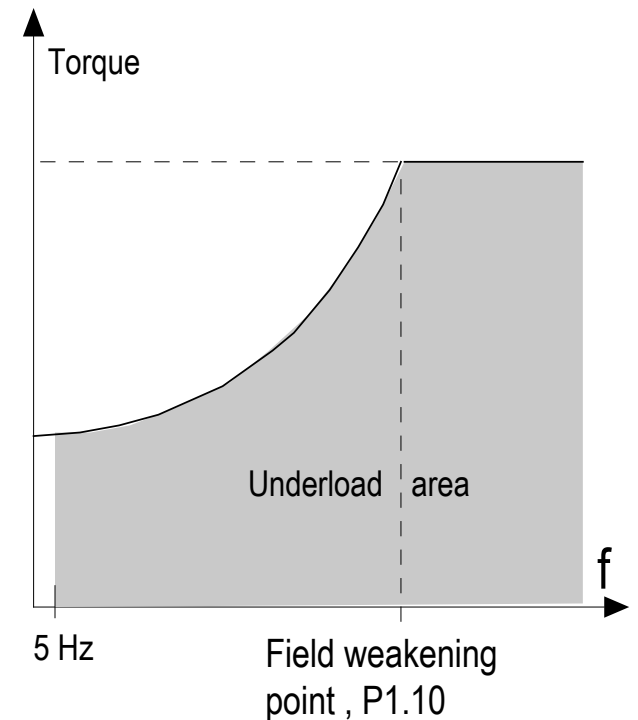

Fig. 59. Underload protection

Motor thermal protection (Mtp)

0 = No action

1 = Alarm

2 = Fault, stop function

3 = Fault, coast „Stop function“ on page 120

If tripping is selected the drive will stop and activate the fault stage, if the temperature of the motor becomes too high. Deactivating the protection, i.e. setting parameter to 0, will reset the thermal model of the motor to 0%.



The motor thermal protection is to protect the motor from overheating. The drive is capable of supplying higher than nominal current to the motor. If the load requires this high current there is a risk that the motor will be thermally overloaded. This is the case especially at low frequencies. At low frequencies the cooling effect of the motor is reduced as well as its capacity. If the motor is equipped with an external fan the load reduction at low speeds is small.

The motor thermal protection is based on a calculated model and it uses the output current of the drive to determine the load on the motor.

The motor thermal protection can be adjusted with parameters. The thermal current I_T specifies the load current above which the motor is overloaded. This current limit is a function of the output frequency.

The thermal stage of the motor can be monitored on the control keypad display.

	CAUTION The calculated model does not protect the motor if the airflow to the motor is reduced by blocked air intake grill.
--	---

	NOTE: To comply with IEC 61800-5-1:2007+A1:2016 requirements motor over-temperature sensing is required at installation if the parameter is set to 0.
	NOTE: If you use long motor cables (max. 100 m) together with small drives (≤ 1.5 kW) the motor current measured by the drive can be much higher than the actual motor current due to capacitive currents in the motor cable. Consider this when setting up the motor thermal protection functions. .

Motor thermal protection (Mtp): Ambient temperature

When the motor ambient temperature must be taken into consideration, it is recommended to set a value for this parameter. The value can be set between -20 and 100 degrees Celsius.

Motor thermal protection (Mtp): Zero speed cooling

Defines the cooling factor at zero speed in relation to the point where the motor is running at nominal speed without external cooling. The default value is set assuming that there is no external fan cooling the motor. If an external fan is used this parameter can be set to 90 % (or even higher).

If you change the parameter P1.4 (Motor nominal current), this parameter is automatically restored to the default value. Setting this parameter does not affect the maximum output current of the drive which is determined by parameter P1.7 alone.

The corner frequency for the thermal protection is 70% of the motor nominal frequency (P1.2).

The cooling power can be set between 0...150.0% × cooling power at nominal frequency. See below:

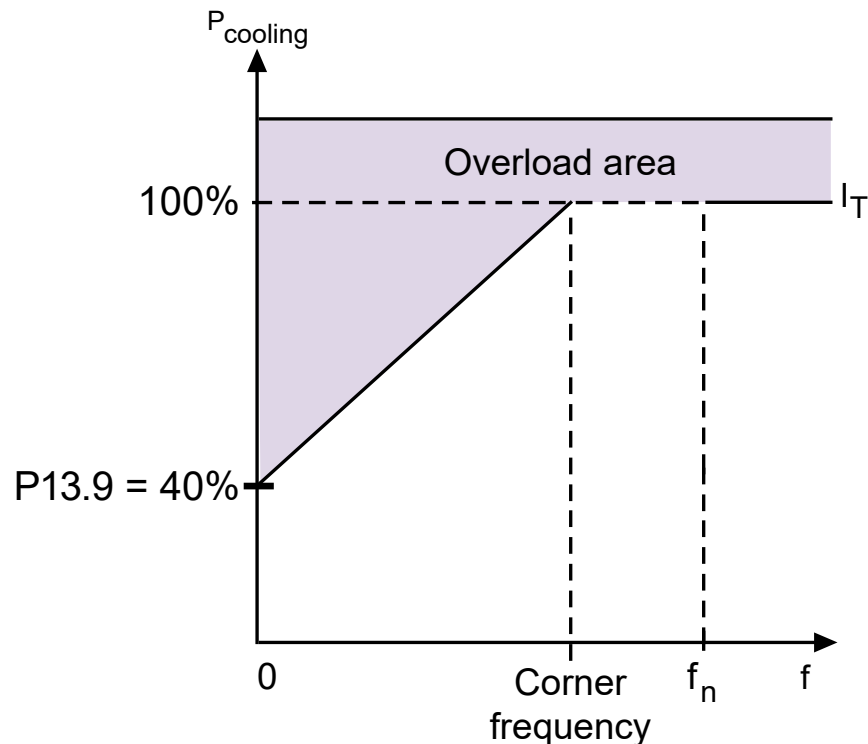

Fig. 60. Motor thermal current I_T curve

Motor thermal protection (Mtp): thermal time constant

This time can be set between 1 and 200 minutes.

This is the thermal time constant of the motor. The bigger the frame and/or slower the speed of the motor, the longer the time constants. The time constant is the time within which the calculated thermal model has reached 63 % of its final value. ()The motor thermal time is specific to the motor design and it varies between different motor manufacturers.

If the motor's t_6 -time (t_6 is the time in seconds the motor can safely operate at six times the rated current) is known (given by the motor manufacturer) the time constant parameter can be set basing on it.

As a rule of thumb, the motor thermal time constant in minutes equals to $2 \times t_6$. If the drive is in stop state the time constant is internally increased to three times the set parameter value.

The cooling in stop stage is based on convection and the time constant is increased. See also figure below.

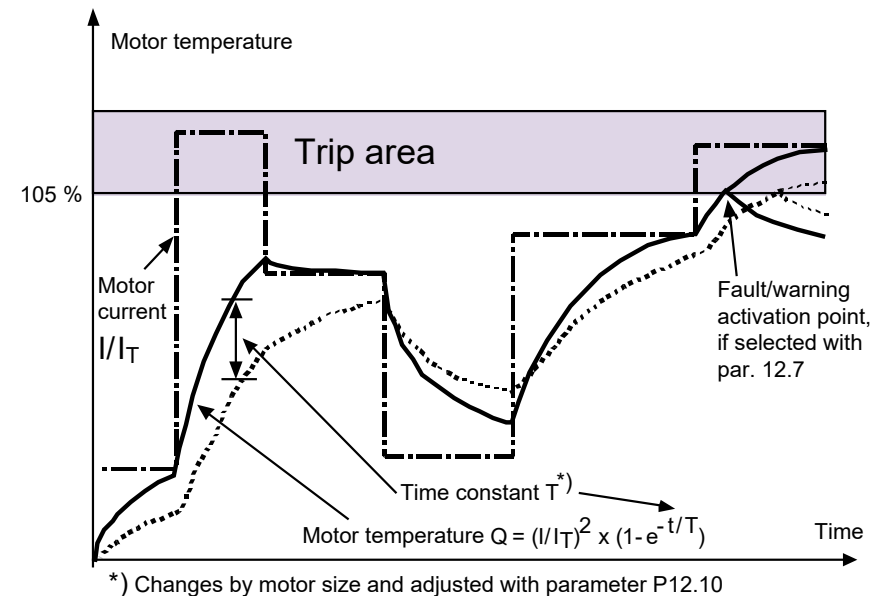

Fig. 61. Motor temperature calculation

Stall current

The current can be set to $0.0 \dots 2 \times I_{N_{unit}}$. For a stall stage to occur, the current must have exceeded this limit. If parameter P1.7 Motor current limit is changed, this parameter is automatically calculated to 90% of the current limit. See figure below:



NOTE:

In order to guarantee desired operation, this limit must be set below the current limit.

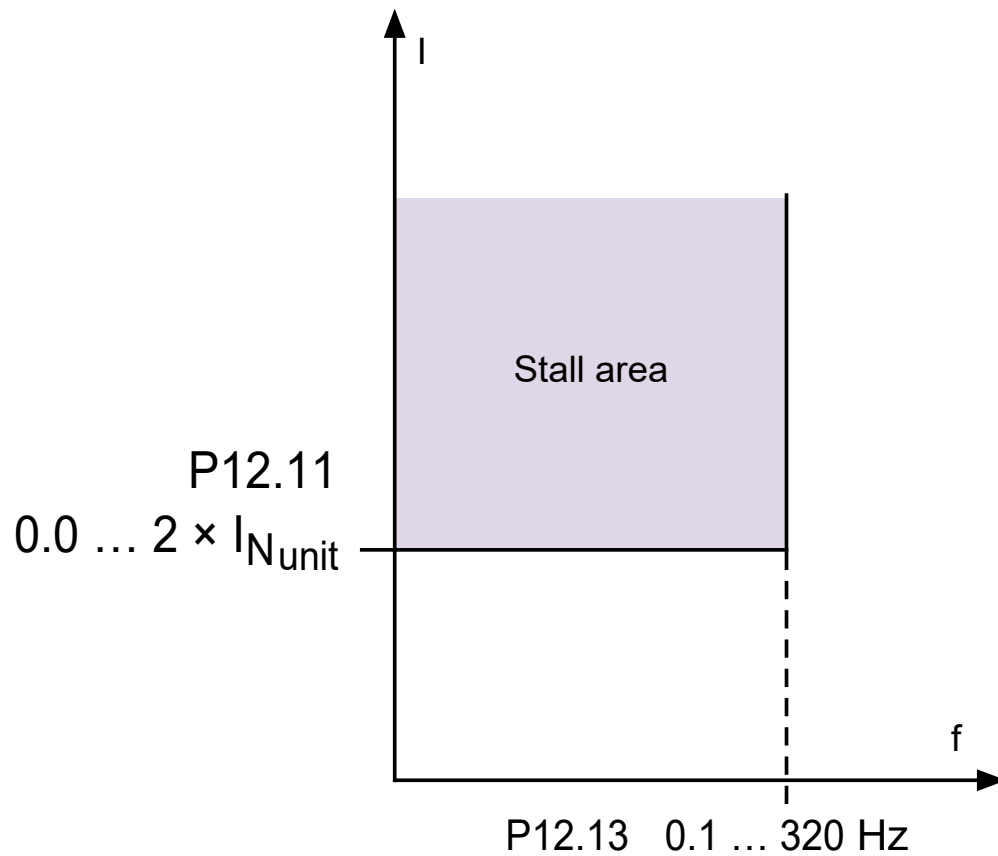

Fig. 62. Stall current

Stall time

This time can be set between 0.00 and 300.00s.

This is the maximum time allowed for a stall stage. The stall time is counted by an internal up/down counter.

If the stall time counter value goes above this limit the protection will cause a trip (see parameter P12.5). See figure below:

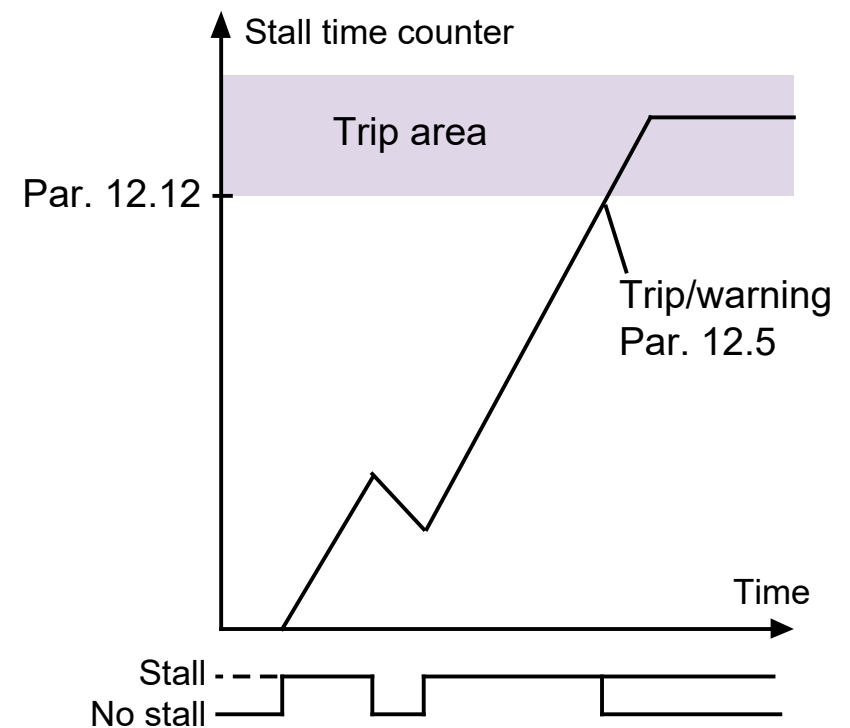

Fig. 63. Stall time calculation

Underload protection:

Field weakening area load

The torque limit can be set between $10.0 - 150.0 \% \times T_{nMotor}$

This parameter gives the value for the minimum torque allowed when the output frequency is above the field weakening point. If you change parameter P1.4 (Motor nominal current) this parameter is automatically restored to the default value.

Underload protection: time limit

This time can be set between 2.0 and 600.0 s.

This is the maximum time allowed for an underload state to exist. An internal up/down counter counts the accumulated underload time. If the underload counter value goes above this limit the protection will cause a trip according to parameter P12.6. If the drive is stopped the underload counter is reset to zero. See figure below:

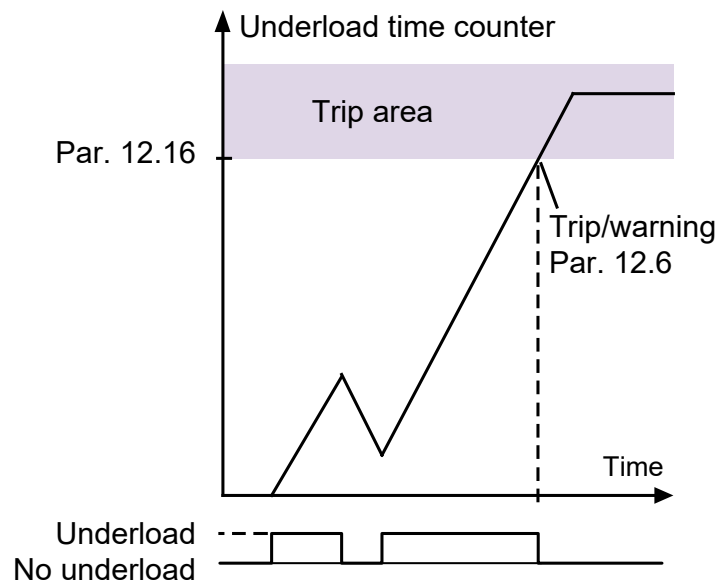

Fig. 64. Underload counter

Input phase fault

- 0: No action
- 1: Alarm
- 2: Fault: Stop function
- 3: Fault: Coast

Motor temperature memory mode

- 0 = disabled
- 1 = constant mode
- 2 = last value mode

10.12 Automatic reset (Control panel: Menu PAR → P13)

Activate the Automatic reset after fault with this parameter.

	NOTE: Automatic reset is allowed for certain faults only.
--	---

- Fault:**
1. Under voltage
 2. Over voltage
 3. Over current
 4. Motor over temperature
 5. Under load

Trial time

The Automatic restart function restarts the frequency converter when the faults have disappeared and the waiting time has elapsed.

The time count starts from the first auto reset. If the number of faults occurring during the trial time exceeds trial number (the value of P13.4), the fault state becomes active. Otherwise the fault is cleared after the trial time has elapsed and the next fault starts the trial time count again. See figure in the right side.

If a single fault remains during the trial time, a fault state is true.

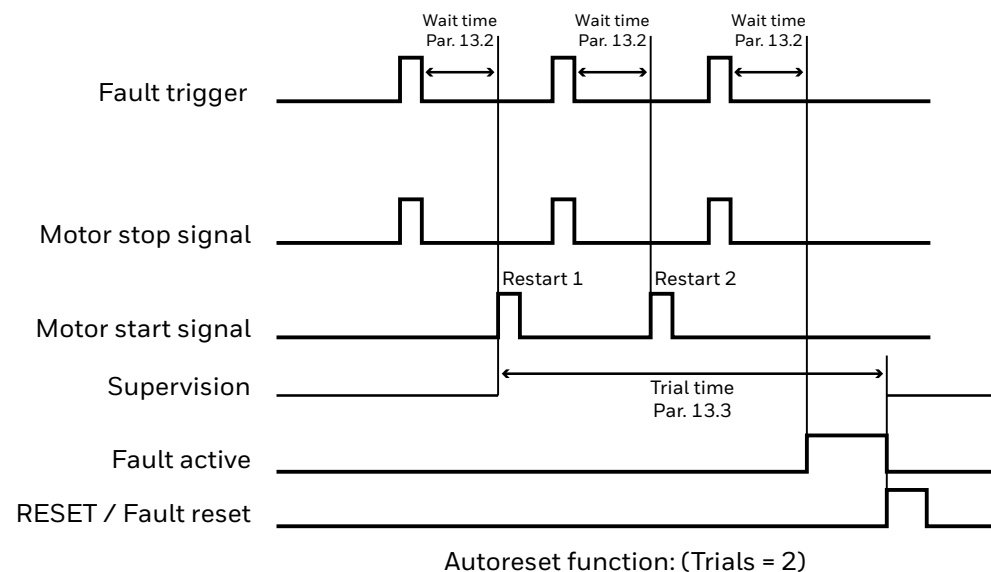

Fig. 65. Example of Automatic restarts with two restarts

10.13 PID control parameters (Control panel: Menu PAR → P14)

Feedback value minimum

Feedback value maximum

This parameter sets the minimum and maximum scaling points for feedback value.

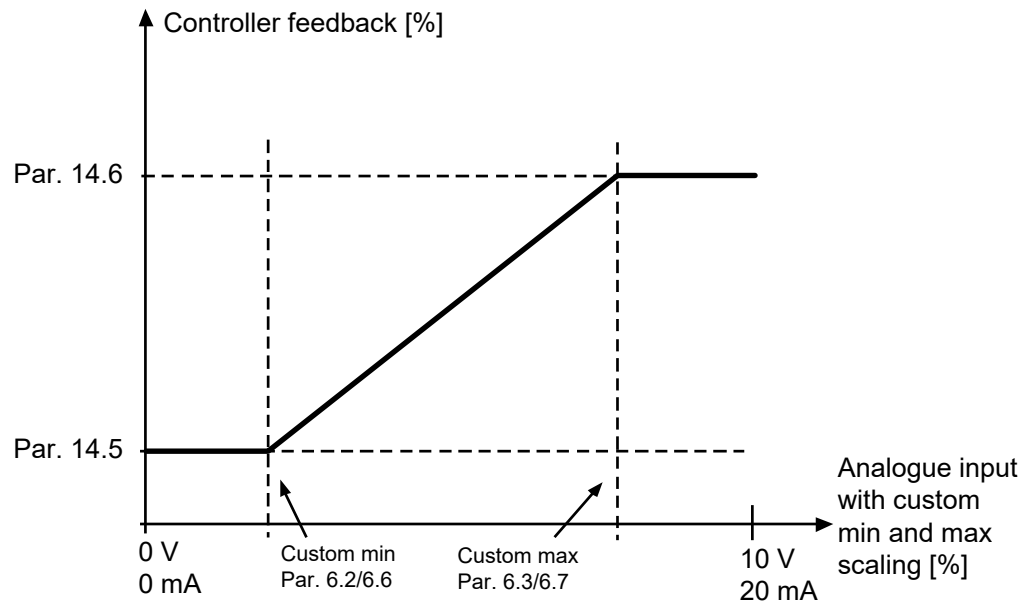

Fig. 66. Feedback minimum and maximum

P gain

This parameter defines the gain of the PID controller. If the value of the parameter is set to 100%, a change of 10% in the error value causes the controller output to change by 10%.

PID controller I-time

This parameter defines the integration time of the PID controller. If this parameter is set to 1,00 second, the controller output is changed by a value corresponding to the output caused from the gain every second. $(\text{Gain} \times \text{Error})/s$.

PID controller D-time

This parameter defines the derivative time of the PID controller. If this parameter is set to 1,00 second, a change of 10% in the error value causes the controller output to change by 10%.

Sleep min frequency

Sleep delay

Wake-up error

This function will put the drive into sleep mode if the frequency stays below the sleep limit for a longer time than that set with the Sleep Delay (P14.12). This means that the start command remains on, but the run request is turned off. When the actual value goes below, or above, the wake-up error depending on the set acting mode (P10.10) the drive will activate the run request again if the start command is still on.

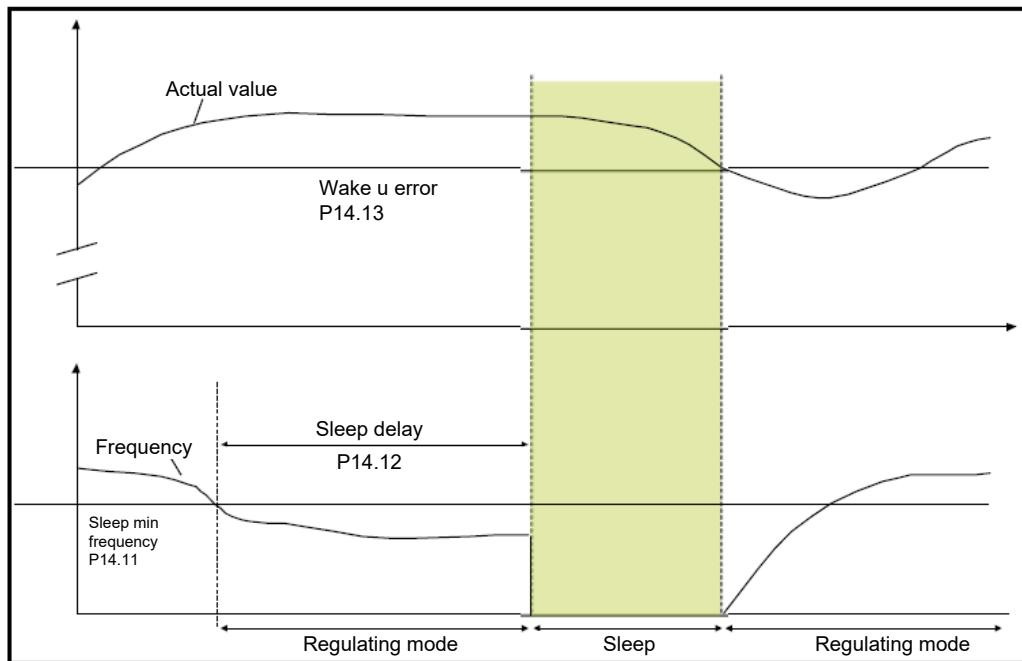

Fig. 67. Sleep min frequency, Sleep delay, Wake-up error

Sleep setpoint boost

Setpoint boost time

Sleep max loss

Sleep loss check time

These parameters manage a more complex sleep sequence. After the time in P14.12, the setpoint is increased of the term in P14.14, for the time in P14.15. This will cause a higher output frequency.

Frequency reference is then forced at minimum frequency and the feedback value is sampled.

If the variation on the feedback value stays then lower than P14.16 for the time in P14.17, the drive will enter sleep condition.

If this sequence is not needed, then program

- P14.14 = 0%,
- P14.15 = 0 s,
- P14.16 = 50%,
- P14.17 = 1 s.

Process unit source selection

Monitor V4.5 can show a process value, proportional to a variable measured by the drive. Source variables are:

- 0** = PID feedback value (max: 100%)
- 1** = Output frequency (max: fmax)
- 2** = Motor speed (max: nmax)
- 3** = Motor torque (max: Tnom)
- 4** = Motor power (max: Pnom)
- 5** = Motor current (max: Inom)

Process unit decimal digits

Number of decimals shown on monitor V4.5.

Process unit min value

Value shown on V4.5 when source variable is at its minimum. Proportionality is kept if source overtakes the minimum.

Process unit max value

Value shown on V4.5 when source variable is at its maximum. Proportionality is kept if source overtakes the maximum.

10.14 Application setting (Control panel: Menu PAR → P15)

Pre heat function

- 0** = not used
- 1** = pre heat current always active in stop state
- 2** = pre heat controlled by digital input defined in P5.17
- 3** = pre heat active when the drive's heat-sink temperature is below the limit in P15.3
- 4** = pre heat active when the external temperature measurements defined in P15.4 are below the limit in P15.5 (option board OPTBH needed)

Pre heat current

Value of DC current to the motor.

Heatsink temperature limit

Considered when P15.1 = 3.

Pre heat current is active when the heatsink temperature is below this value.

External temperature selection

Bit wise selection of temperature inputs.

- **B0** = Temperature input 1
- **B1** = Temperature input 2
- **B2** = Temperature input 3



NOTE:

OPTBH parameters (in System menu) for setting of the sensor type must be configured accordingly.

External temperature limit

Considered when P15.1 = 4.

Pre heat current is active when the external temperature is below this value.

If more than one temperature input is configured in P15.4, the maximum measurement will be considered.

10.15 Application setting (Control panel: Menu PAR → P16)

Active fire mode parameter group

This parameter is visible only when start wizard is active. With this parameter you can enable/disable fire mode parameters during start wizard.

Application access password

Input the right password could review parameter group 18.

10.16 System parameter

Password

HVAC232/402 API provides password function that is used when changing parameter value.

Inside PAR or SYS menu the selected parameter symbol and its value are alternating in the display. The single OK button pressing causes entering to the parameter value change mode.

If password protection is ON, user is asked to enter the right password (defined with parameter P4.3) and press OK button before editing value is possible. The password consists of four digit numbers, factory default value is 0000 = Password Disabled. Editing of all the parameters (including System parameters) is prohibited if the correct password has not been entered. If wrong password is entered, pressing OK button causes return to the main level.

Password parameters:

HVAC232/402 API has one password parameter P4.3 "Password";

Parameter P4.3 is a 4 digit number. Factory default will be 0000 = Password disabled;

Any other value than 0000 will enable the password and it is not possible to change parameters. In this status all parameters are visible;

When navigate to Parameter P4.3, show "PPPP" as a parameter value if password has been set.

Activating a password:

Navigate to Parameter P4.3; Press OK button;

Cursor(lowest horizontal segment) of the very left digit flashes;

Select first digit of password by using UP and DOWN key;

Press RIGHT button;

Cursor of the second digit flashes;

Select second digit of password by using UP and DOWN key;

Press RIGHT button;

Cursor of the third digit flashes;

Select third digit of password by using UP and DOWN key;

Press RIGHT button;

Cursor of the fourth digit flashes;

Select fourth digit by using UP and DOWN key;

Press OK button → the cursor of the first digit flashes;

Repeat insertion of password;

Press OK button → password is locked;

In case of different values for the two passwords: display Fault;

Press OK button → repeat password a second time;

To interrupt insertion of Password → Press BACK/RES.

Disabling a password:

Insert the actual password → Press OK → Password is automatically set to 0000;

All parameters can then freely be changed;

To enable password again → see 'Activating a password' procedure.

CHANGE OF ONE PARAMETER:

User tries to change a parameter value when password is enabled → display PW;

Press OK button;

Cursor (lowest horizontal segment) of the very left digit flashes;

Select first digit of password by using UP and DOWN key;

Press RIGHT button;

Cursor of the second digit flashes;

Select second digit of password by using UP and DOWN key;

Press RIGHT button;

Cursor of the third digit flashes;

Select third digit of password by using UP and DOWN key;

Press RIGHT button;

Cursor of the fourth digit flashes;

Select fourth digit by using UP and DOWN key; Press OK button;

Current value of parameter to be changed will be display;

Change parameter value as normal;

Press OK --> New parameter value will be stored and Password is enabled again;

For changing another parameter the procedure has to be repeated;

In the case of wanting to change multiple parameters it is of advantage to set P4.3 to 0000;

After the change of the parameter values password has to be activated again;

FORGOTTEN PASSWORD:

Follow procedure “Disabling a password” and select 6020 as actual password.

10.17 Modbus RTU

HVAC232/402 has a built-in ModbusRTU bus interface. The signal level of the interface is in accordance with the RS-485 standard.

The built-in Modbus connection of HVAC232/402 supports the following function codes:

Table 52. Modbus RTU

Function code	Function name	Address	Broadcast messages
03	Read holding registers	All ID numbers	No
04	Read input registers	All ID numbers	No
06	Write single registers	All ID numbers	Yes
16	Write multiple registers	All ID numbers	Yes

10.18 Termination resistor

The RS-485 bus is terminated with termination resistors of 120 ohms in both ends. HVAC232/402 has a built-in termination resistor which is switched off as a default (presented below). The termination resistor can be switched on and off with the right hand dip switch located above IO-terminals in the front of the drive (see below).

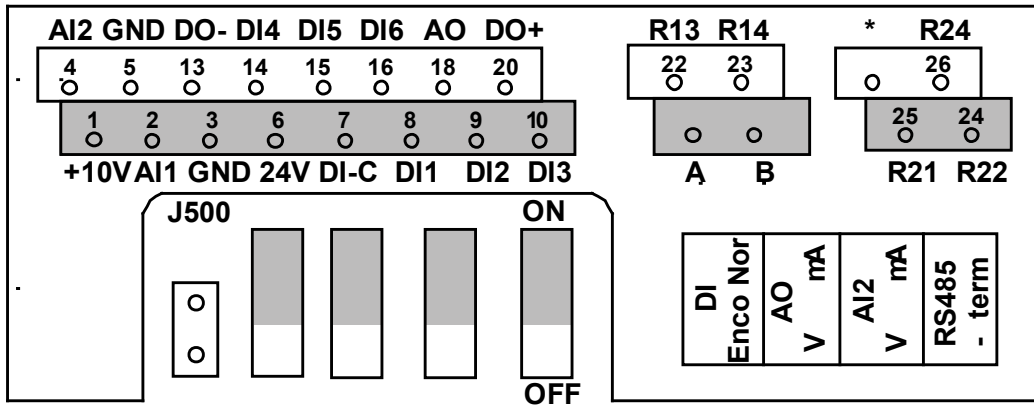

*ENCO = logic input configured as encoder input

Fig. 68. HVAC232/402 I/O

10.19 Modbus address area

The Modbus interface of HVAC232/402 uses the ID numbers of the application parameters as addresses. The ID numbers can be found in the parameter tables in „9 Standard application parameters“ on page 55. When several parameters / monitoring values are read at a time, they must be consecutive. 11 addresses can be read and the addresses can be parameters or monitoring values.

NOTE:

With some PLC manufacturers, the interface driver for Modbus RTU communication may contain an offset of 1 (the ID number to be used would then subtract 1).

10.20 Modbus process data

Process data is an address area for fieldbus control. Fieldbus control is active when the value of parameter 2.1 (Control place) is 1 (= fieldbus). The content of the p()rocess data can be programmed in the application. The following tables present the process data contents in HVAC232/402 Application.

Table 53. Output process data

ID	Modbus register	Name	Scale	Type
2101	32101, 42101	FB Status Word	–	Binary coded
2102	32102, 42102	FB General Status Word	–	Binary coded
2103	32103, 42103	Reserved	0,01	%
2104	32104, 42104	Programmable by P9.1 (Default: Frequency reference)	–	–
2105	32105, 42105	Programmable by P9.2 (Default: Output frequency)	0,01	± Hz
2106	32106, 42106	Programmable by P9.3 (Default: Motor speed)	1	± Rpm
2107	32107, 42107	Programmable by P9.4 (Default: Motor voltage)	0,1	V
2108	32108, 42108	Programmable by P9.5 (Default: Motor torque)	0,1	± % (of nominal)
2109	32109, 42109	Programmable by P9.6 (Default: Motor current)	0,01	A
2110	32110, 42110	Programmable by P9.7 (Default: Motor power)	0,1	± % (of nominal)
2111	32111, 42111	Programmable by P9.8 (Default: DC link voltage)	1	V

Table 54. Input process data

ID	Modbus register	Name	Scale	Type
2001	32001, 42001	FB Control Word	–	Binary coded
2002	32002, 42002	FB General Control Word	–	Binary coded
2003	32003, 42003	Frequency reference	0,01	0...10'000
2004	32004, 42004	Programmable by P9.9		
2005	32005, 42005	Programmable by P9.9		
2006	32006, 42006	Programmable by P9.9		
2007	32007, 42007	Programmable by P9.9		
2008	32008, 42008	Programmable by P9.9		
2009	32009, 42009	–	–	–
2010	32010, 42010	–	–	–
2011	32011, 42011	–	–	–





	<p>NOTE: 2004 - 2007 can set as PID Control Reference by setting P14.1 (Setpoint selection) or PID Actual value by setting P14.4 (Feedback value selection)!</p>
	<p>NOTE: 2004 - 2007 can be set as the Analogue Output by P8.1, P8.5, P8.9.</p>
	<p>NOTE: 2004 - 2008 can set as Aux Control Word with P9.9: <i>b0: Run enable</i> <i>b1: acc / dec ramp 2 selection</i> <i>b2: freq reference 2 selection</i></p>
	<p>NOTE:</p> <ul style="list-style-type: none"> • AUX CW is active when configured, even if control place is not the fieldbus • b0 Run enable is computed in AND with a possible Run enable signal from digital input. Fall of enable will cause coasting stop.

Table 55. Status word (output process data)

Bit	Description	
	Value = 0	Value = 1
B0, RDY	Drive not ready	Drive ready
B1, RUN	Stop	Run
B2, DIR	Clockwise	Counter-clockwise
B3, FLT	No fault	Fault active
B4, W	No alarm	Alarm active
B5, AREF	Ramping	Speed reference reached
B6, Z	–	Drive is running at zero speed
B7 - B15	–	–

Status word (output process data)

Information about the status of the device and messages is indicated in the Status word. The Status word is composed of 16 bits the meanings of which are described in the table below:

General status word (output process data)

Information about the status of the device and messages is indicated in the General status word. The General status word is composed of 16 bits the meanings of which are described in the table below:

Table 56. General status word (output process data)

Bit	Description			
	Value = 0		Value = 1	
B0, RDY	Drive not ready		Drive ready	
B1, RUN	Stop		Run	
B2, DIR	Clockwise		Counter-clockwise	
B3, FLT	No fault		Fault active	
B4, W	No alarm		Alarm active	
B5, AREF	Ramping		Speed reference reached	
B6, Z	–		Drive is running at zero speed	
B7	–		Fieldbus control active	
B8 - B12	–		–	
Bit	Control place			
	I/O	PC tool	Keypad	Fieldbus
B13	1	0	0	0
B14	0	1	1	0
B15	0	1	0	1

Actual speed (output process data)

This is actual speed of the frequency converter. The scaling is –10000...10000. The value is scaled in percentage of the frequency area between set minimum and maximum frequency.

Control word (input process data)

The three first bits of the control word are used to control the frequency converter. By using control word it is possible to control the operation of the drive. The meanings of the bits of control word are explained in the table below:

Table 57. Control word (input process data)

Bit	Description	
	Value = 0	Value = 1
B0, RUN	Stop	Run
B1, DIR	Clockwise	Counter-clockwise
B2, RST	Rising edge of this bit will reset active fault	
B5, Quick ramp time	Normal deceleration ramp time	Quick deceleration ramp time

Speed reference (input process data)

This is the Reference 1 to the frequency converter. Used normally as Speed reference. The allowed scaling is 0...10000. The value is scaled in percentage of the frequency area between the set minimum and maximum frequencies.

11 Technical data

11.1 HVAC232/402 technical data

Table 58. HVAC232/402 technical data.

Mains connection	Input voltage U_{in}	208 ... 240 V, -15% ... +10% 1~ 380 ... 480 V, -15% ... +10% 3~
	Input frequency	45 ... 66 Hz
	Connection to mains	Once per minute or less (normal case)
Supply network	Networks	HVAC232/402 cannot be used with corner grounded networks
	Short circuit current	Maximum short circuit current has to be < 50 kA
Motor connection	Output voltage	0 - U_{in}
	Output current	Continuous rated current I_N at ambient temperature max. +50 °C (depends on the unit size), overload $1.5 \times I_N$ max 1 min / 10 min
	Starting current / torque	Current $2 \times I_N$ for 2 sec in every 20 sec period. Torque depends on motor
	Output frequency	0 ... 320 Hz
	Frequency resolution	0,01 Hz
Control connection	Digital input	Positive, Logic "1": 18 ... +30 V, Logic "0": 0 ... 5 V; Negative, Logic "1": 0 ... 10 V, Logic "0": 18 ... 30 V; $R_i = 10 \text{ K}\Omega$ (floating)
	Analogue input voltage	0 ... +10 V, $R_i = 250 \text{ K}\Omega$
	Analogue input current	0(4) ... 20 mA, $R_i \leq 250 \Omega$
	Analogue output	0 ... 10 V, $R_L \geq 1 \text{ K}\Omega$; 0(4) ... 20 mA, $R_L \leq 500 \Omega$, Selectable through microswitch
	Digital output	Open collector, max. load 35V/50mA (floating)
	Relay output	Switching load: 250 Vac/3 A, 24 V DC 3 A
	Auxiliary voltage	$\pm 20\%$, max. load 50 mA

Control characteristics	Control method	Frequency Control U/f Open Loop Sensorless Vector Control
	Switching frequency	1 ... 16 kHz; Factory default 4 kHz
	Frequency reference	Resolution 0.01 Hz
	Field weakening point	30 ... 320 Hz
	Acceleration time	0.1 ... 3000 sec
	Deceleration time	0.1 ... 3000 sec
	Braking torque	100% × T _N with brake option (only in 3~ drives sizes MI2-5) 30% × T _N without brake option
Ambient conditions	Ambient operating temperature	14 °F (-10 °C) (no frost) ... +104/122 °F (+40/50 °C) (depends on the unit size): rated loadability I _N Side by side installation for MI1-3 it is always 104 °F (40 °C); For IP21/Nema1 option in MI1-3 the maximum temperature is also 104 °F (40 °C)
	Storage temperature	-40 °F (-40 °C) ... +158 °F (70 °C)
	Relative humidity	0 ... 95% RH, non-condensing, non-corrosive, no dripping water
	Air quality: • chemical vapours • mech. particles	• IEC 721-3-3, unit in operation, class 3C2 • IEC 721-3-3, unit in operation, class 3S2
	Altitude	• 100% load capacity (no derating) up to 3281 ft. (1000 m). • 1% derating for each 328 ft. (100 m) above 3281 ft. (1000 m); • max. 6562 ft. (2000 m)
	Vibration: EN60068-2-6	• 3 ... 150 Hz • displacement amplitude 1(peak) mm at 3 ... 15.8 Hz max • acceleration amplitude 1 G at 15.8 ... 150 Hz
	Shock IEC 68-2-27	• UPS Drop Test (for applicable UPS weights) • Storage and shipping: max 15 G, 11 ms (in package)
	Enclosure class	IP20 for MI1-3, IP21 for MI4-5 or MI-1-3 with accessory COMP-IP21-KIT# / COMP-NEMA1-KIT#
	Pollution degree	PD2

EMC	Immunity	Complies with EN50082-1, -2, EN61800-3
	Emissions	230 V : Complies with EMC category C2; With an internal RFI filter MI4&5 complies C2 with a DC choke and CM choke 400 V: Complies with EMC category C2; With an internal RFI filter MI4&5 complies C2 with a DC choke and CM choke
Standards		For EMC: EN61800-3, For safety: EN61800-5
Certificates and manufacturer's declarations of conformity		For safety: CE For EMC: CE (see unit nameplate for more detailed approvals)

12 PART NUMBERS, POWER RATINGS, SIZE, AND WEIGHT

12.1 Part Number Options

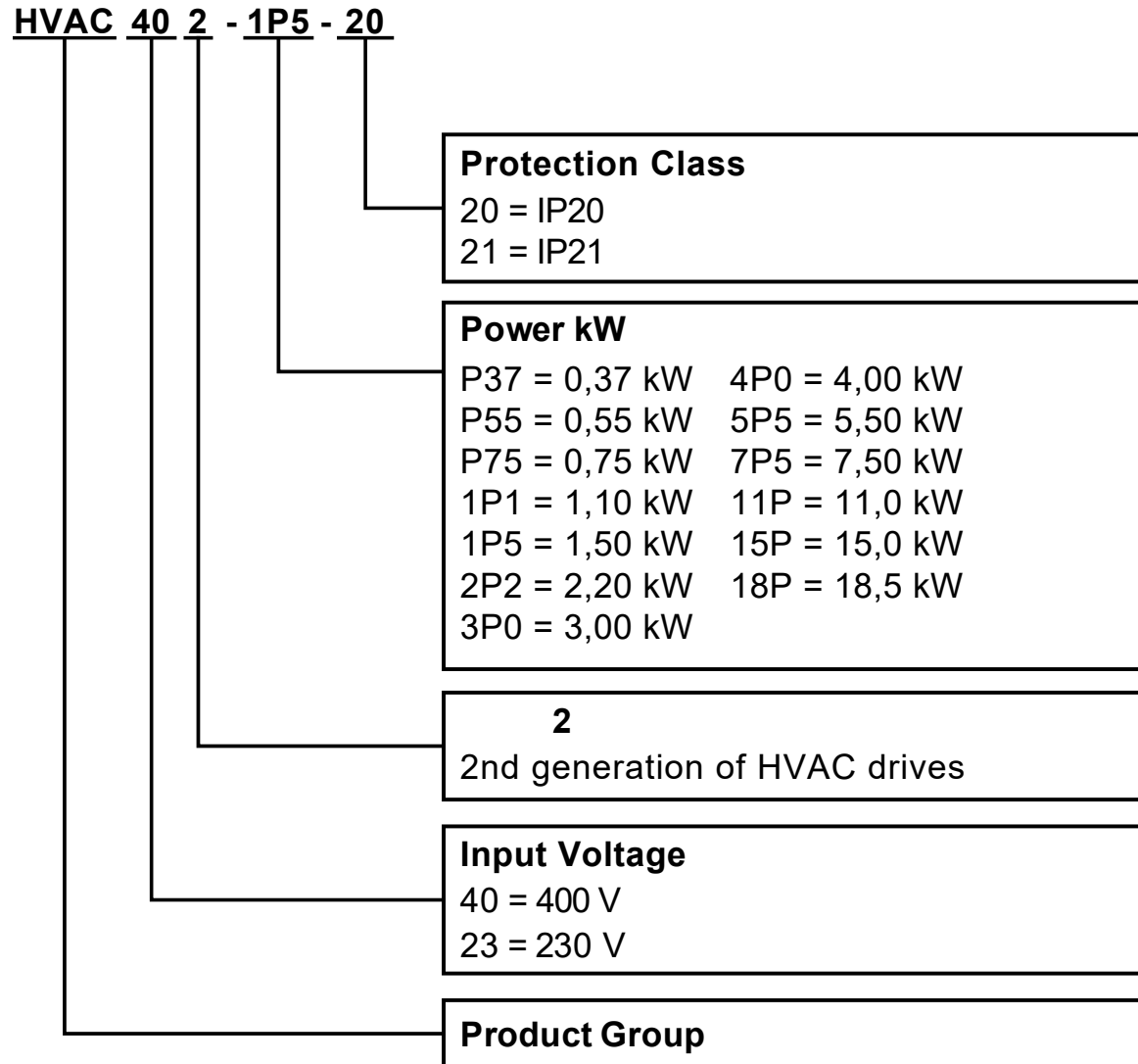

Fig. 68. HVAC232/402 part number options.

12.2 Low overload

Low overload = 150% starting torque, 2 sec/20 sec, 110% overloadability, 1 min/10 min

Following continuous operation at rated output current, 110% rated output current (IL) for 1 min, followed by a period of load current less than rated current, and of such duration that the r.m.s output current, over the duty cycle, does not exceed rated output current (IL).

12.3 High overload

High overload = 200% starting torque, 2 sec/20 sec, 150% overloadability, 1 min/10 min

Following continuous operation at rated output current, 150 % rated output current (IH) for 1 min, followed by a period of load current less than rated current, and of such duration that the r.m.s output current, over the duty cycle, does not exceed rated output current (IH).

12.4 HVAC232/402 – Mains voltage 208-240 V

Table 59. Mains voltage 208-240 V, 50/60 Hz, 1~ series.



Part number	Rated loadability		Motor shaft power		Nominal input current	Mechanical size	Weight [kg]
	100% continuous current I_N [A]	150% overload current [A]	P [HP]	P [KW]	[A]		
HVAC232-P37-20	2,4	3,6	0,5	0,37	5,7	MI1	0,55
HVAC232-P55-20	2,8	4,2	0,75	0,55	6,6	MI1	0,55
HVAC232-P75-20	3,7	5,6	1,0	0,75	8,3	MI2	0,70
HVAC232-1P1-20	4,8	7,2	1,5	1,1	11,2	MI2	0,70
HVAC232-1P5-20	7,0	10,5	2,0	1,5	14,1	MI2	0,70
HVAC232-2P2-20*	9,6	14,4	3,0	2,2	22,1	MI3	0,99

* The maximum ambient operating temperature of this drive is 104 °F (40 °C)

Table 60. Mains voltage 208 - 240 V, 50/60 Hz, 3~ series.

Part number	Rated loadability		Motor shaft power		Nominal input current [A]	Mechanical size	Weight [kg]
	100% continuous current I _N [A]	150% overload current [A]	P [HP]	P [KW]			
HVAC402-P55-20	1,9	2,9	0,75	0,55	2,8	MI1	0,55
HVAC402-P75-20	2,4	3,6	1	0,75	3,2	MI1	0,55
HVAC402-1P1-20	3,3	5	1,5	1,1	4	MI2	0,70
HVAC402-1P5-20	4,3	6,5	2	1,5	5,6	MI2	0,70
HVAC402-2P2-20	5,6	8,4	3	2,2	7,3	MI2	0,70
HVAC402-3P0-20	7,6	11,4	4	3	9,6	MI3	0,99
HVAC402-4P0-20	9	13,5	5	4	11,5	MI3	0,99
HVAC402-5P5-20	12	18	7,5	5,5	14,9	MI3	0,99
HVAC402-7P5-21	16	24	10	7,5	17,1	MI4	8,68
HVAC402-11P-21	23	34,5	15	11	25,5	MI4	8,68
HVAC402-15P-21	31	46,5	20	15	33	MI5	11,07
HVAC402-18P-21	38	57	25	18,5	41,7	MI5	11,07

* The maximum ambient operating temperature of this drive is 104 °F (40 °C)

	NOTE: The input currents are calculated values with 100 kVA line transformer supply.
	NOTE: The mechanical dimensions of the units are given in „3.2 HVAC232/402 dimensions“ on page 14.
	NOTE: For PM motor, please select the drive power rating according to motor shaft power, not rated current.

13 ACCESSORIES

Part number	Description
ENC-SLOT MI1-MI3	Enclosure for boards FR MI1-MI3 (externally mounted)
ENC-SLOT MI4-MI5	Enclosure for boards FR MI4-MI5 (internally mounted)
HVACDOORKIT	Keypad door mounting kit
COMP-IP21-KIT1	Upgrade enclosure MI1 frame; IP21
COMP-IP21-KIT2	Upgrade enclosure MI2 frame; IP21
COMP-IP21-KIT3	Upgrade enclosure MI3 frame; IP21
COMP-NEMA1-KIT1	IP21 enclosure upgrade kit with additional wiring terminal cover for SmartDrive Compact size MI1
COMP-NEMA1-KIT2	IP21 enclosure upgrade kit with additional wiring terminal cover for SmartDrive Compact size MI2
COMP-NEMA1-KIT3	IP21 enclosure upgrade kit with additional wiring terminal cover for SmartDrive Compact size MI3
COMP-LOADER	For PC connection interface with 3m cable and USB port

By using this Honeywell literature, you agree that Honeywell will have no liability for any damages arising out of your use or modification to, the literature. You will defend and indemnify Honeywell, its affiliates and subsidiaries, from and against any liability, cost, or damages, including attorneys' fees, arising out of, or resulting from, any modification to the literature by you.

Manufactured for and on behalf of the Connected Building Division of Honeywell Products and Solutions SARL,
Z.A. La Pièce, 16, 1180 Rolle, Switzerland by its Authorized Representative:

Honeywell GmbH
Böblinger Strasse 17
71101 Schönaich
Germany

Phone (49) 7031 63701
Fax (49) 7031 637493

<http://ecc.emea.honeywell.com>

® U.S. Registered Trademark
© 2017 Honeywell International Inc.

Document No.: 27-652 - Rev ENG06 - 2019-08-07

Honeywell



27-652_ENG06