

PCD1.B1120-A20

E-Line RIO 16DI, 4Rel

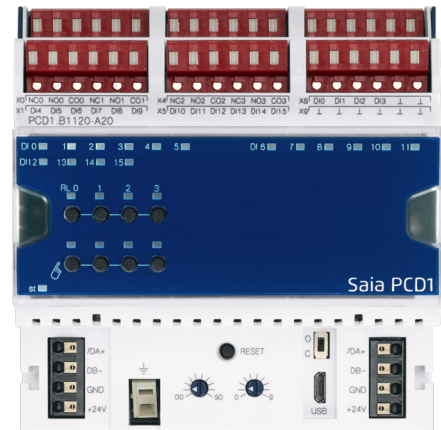

The S-Serie E-Line RIO modules are controlled via the RS-485 serial communication protocols S-Bus and Modbus for decentralised automation using industrial quality components. The data point mix is specifically designed for building automation applications.

The compact design according to DIN 43880 enables the use in electrical distribution boxes even in the most confined spaces. Installation and maintenance are facilitated by the local manual override for each output. Remote maintenance is also possible using the access to the manual override by the web interface in the Saia PCD® controller. Programming is very efficient and fast using a complete FBox library with web templates for S-Bus. Individual programs may directly access the data points via Registers and Flags, a complete documentation is available from this data sheet.

Features

- S-Bus protocol optimized for fast data exchange
- Modbus protocol for integration in multi-vendor installations*
- Local override operating level via web panel or buttons on the module
- Easy programming using the FBox library and web templates
- Industrial hardware in accordance with IEC EN 61131-2
- Pluggable terminal blocks
- Bridge connectors for power supply and communication
- Bus termination on board
- Configurable Bi-Colour LEDs and labelling for I/Os

* By default the module is working in S-Bus Data Mode with Autobaud detection. To configure Modbus the Windows based Application "E-LineApp" is required.

General technical data

Power supply

Supply voltage	24 VDC, -15/+20% max. incl. 5% ripple (in accordance with EN/IEC 61131-2)
Power consumption	1.2 ... 3 W
Power supply bridge	24 VDC, 5 A max., up to 40 modules

Interfaces

Communications interface	► RS-485 Baud rate: 9,600, 19,200, 38,400, 57,600, 115,200 bps (Autobauding) ► Micro USB, Type B
Address switch	Two rotary switches 0 ... 9 Address range 0 ... 98
Bus termination	Integrated switch to activate and inactivate resistor termination

General data

Ambient temperature	Operation: 0 ... +55°C Storage: -40 ... +70°C
Protection class	IP 20
Package	Single carton package with 1 Module incl. terminal blocks, 1 bridge connector

Dimensions and installation

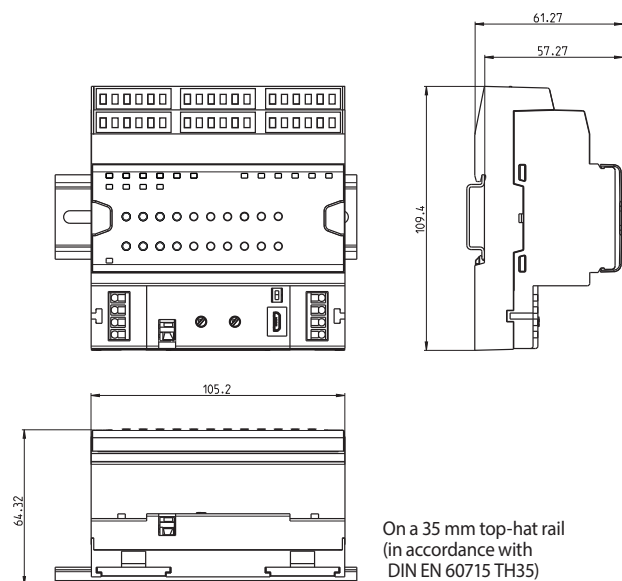

Housing width 6 HP (105 mm)
Compatible with electrical control cabinet (in accordance with DIN 43880, size 2 × 55 mm)

Terminal technology

Push-in spring terminals enable wiring with rigid or flexible wires with a diameter up to 1.5 mm². A max. of 1 mm² is permitted with cable end sleeves.

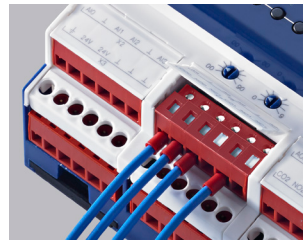

Connection concept

For easy installation the power supply and communication bus is available together at one connector. The push-in spring terminals enable wiring as well support the connector bridge.

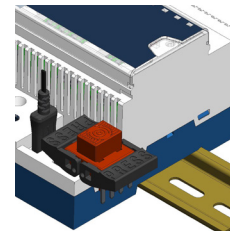
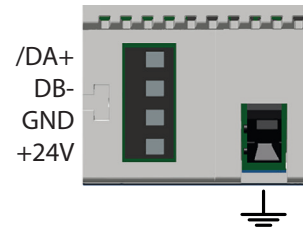

Bus termination

The module provides an active bus termination. It is switched off by factory default. To enable the termination, the switch need to be in the "Close" position.

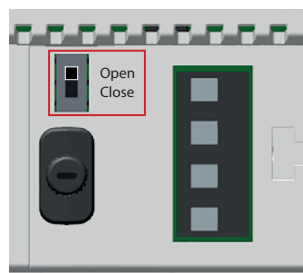

Status LED

OFF	No Power
Green	Communication OK
Green blink	Auto bauding in progress
Orange	No communication
Red	Error
Red/Green alternate	Booter mode (e.g. during Firmware download)
Red blink	Internal fatal error



Service interface

The USB interface provides access to the communication protocol configuration. Firmware updates can also be downloaded via Saia PG5[®] Firmware Download tool.

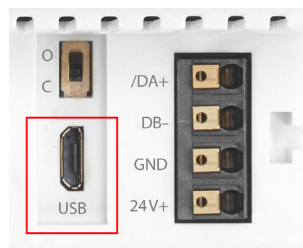

Reset button

Pushed over 20 seconds: The button needs to be pushed for minimum 20 seconds and released during the first minute after power up. All user settings are reset to factory default values.

Pushed at power up: Power off the device and press the button. Power on and release the button before 5 seconds have passed. The device stays in boot mode for further actions like firmware download etc.

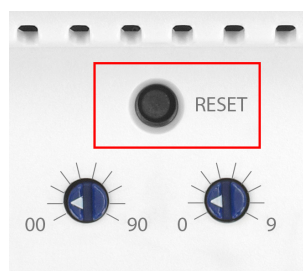

Input/output configuration

Digital inputs

Number	16
Input voltage	24 VDC, source operation (positive switching)
Switching level	Low: 0...5 V High: 15...24 V
Input current	Typically: 2 mA
Input filter time (DC)	Typically: 8 ms

Relays

Number	4 changeover
Max. switching voltage	250 VAC / 30 VDC
Max. switching current	5 A (AC1, DC1)
Contact lifetime*	5 A, 250 VAC, resistive, 85°C, 6 cycles/min, 50% df, EN61810-1, 1×10 ⁵ 5 A, 30 VDC, resistive, on NO-contact, 85°C, 6 cycles/min, 50% duty factor, EN61810-1, 1×10 ⁵ 5 A, 240 VAC, resistive load, on NO or NC contact, UL508, 1×10 ⁵
Switching delay	Timing response: 10 ms under 24 VDC
Relay coil supply	Internally provided (Power Supply of the module)
Module power supply	The power supply to be able to switch correctly the relays up to 85°C is recommended between 21.6 V ... 32 V 20 °C : 17,0 ... 32 VDC 30 °C : 18,0 ... 32 VDC 40 °C : 18,6 ... 32 VDC 50 °C : 19,2 ... 32 VDC
Manual operation	Local override operation by buttons
Limitation	The isolation between two adjacent relays will not be big enough to switch two different phases of 230 VAC

* there are no suppressors fitted to the module; these must be provided externally

Assignment overview

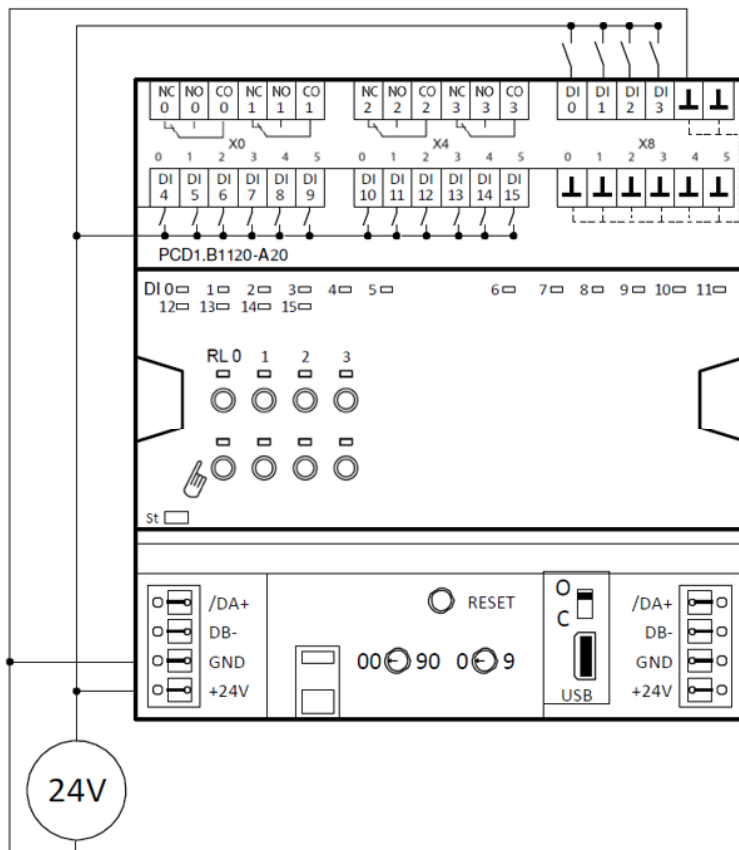

Connection diagrams

Digital inputs

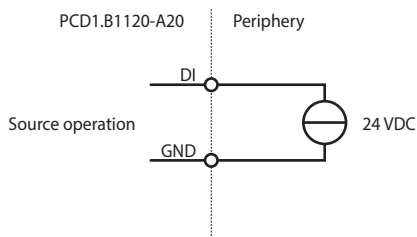

Relay output

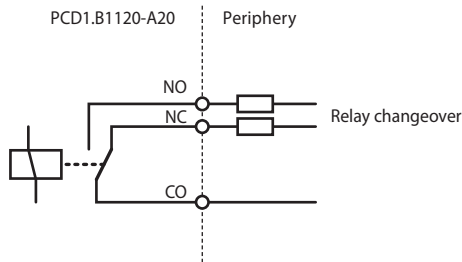

Power supply and bus termination

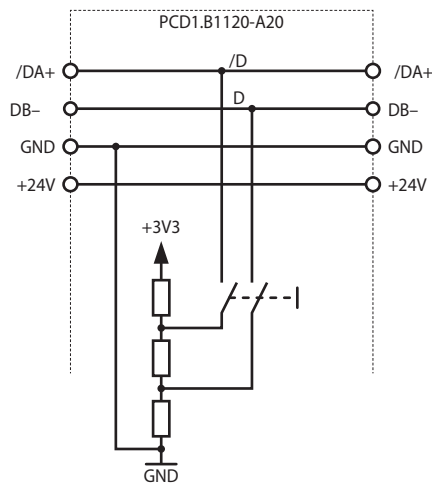

LED Signalisation

Status LED

OFF	No Power
Green	Communication OK
Green blink	Auto bauding in progress
Orange	No communication
Red	Error
Red/Green alternate	Booter mode (e.g. during Firmware download)
Red blink	Internal fatal error

Digital output

The Output indication LED can be configured in colour and blink code separately for output state Low and High.

LED colour

- ▶ Off
- ▶ Red
- ▶ Green*
- ▶ Orange (red + green)

LED blink code

- ▶ No blink*
- ▶ Slow blinking (0.5 flashes per second)
- ▶ Fast blinking (2 flashes per second)

*Factory default

Manual mode

The Manual override LED is Off in automatic mode and orange in case of manual override is active.

LED colour

- ▶ Off (automatic)
- ▶ Orange manual mode active

LED blink code

- ▶ No blink (local manual override)
- ▶ Blinking 1 flash per second (remote manual override)



The modules are addressed and programmed with Saia PG5® Fupla FBoxes. Web templates are available for the operation and visualisation of the manual override function.

Fupla

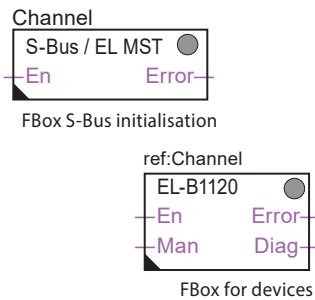
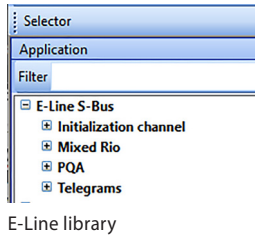

Communication FBox

- ▶ Data exchange for I/O via optimised S-Bus
- ▶ Configurable save state for bus interruption or timeout
- ▶ Direct generation of the symbols
- ▶ Reading and writing of the status of the manual override status
- ▶ Direct compatibility with web macros



Further information, including which FBoxes are supported, Getting Started, etc., can be found on our support page www.sbc-support.com.

Web templates

Web templates are available for the operation and visualisation of the manual override function.

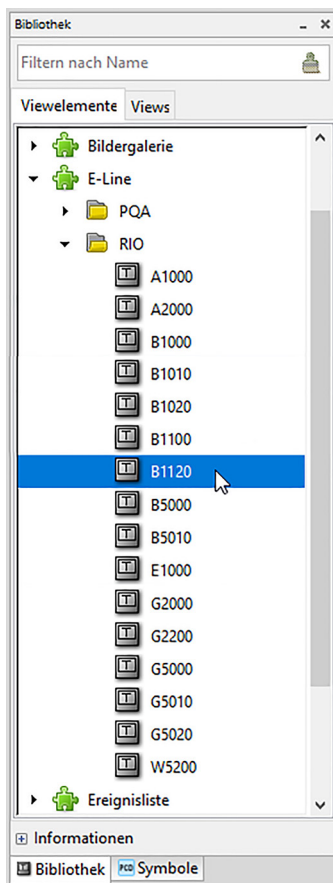

The inputs of the E-Line RIO modules can be addressed via the standard S-Bus. However the FBox from the E-Line library is used for the configuration of these modules. It is therefore recommended to use the optimised S-Bus protocol and the corresponding FBoxes from the E-Line library. Mixed mode operation is not recommended.

Manual operation



By using the local override function, commissioning can take place independently of the master station. In addition, the manual operation can also be controlled remotely using a touch panel. If the bus line is cut off, the module keeps the manually set values. Traditional manual operation in the control cabinet door via potentiometers and switches can therefore be completely replaced by this solution.

Five operating modes can be selected for the manual operating function:

Operating modes	Description	Operation	
		at the module	via remote communication
1	Manual operation deactivated	✗	✗
2	Operation permitted from the module only	✓	✗
3	Operation permitted from the module and limited operation from the panel. If manual operation is activated at the module, it cannot be reset from the panel.	✓	(conditional)
4	Unlimited operation from the panel and module	✓	✓
5	Panel operation (remote)	✗	✓





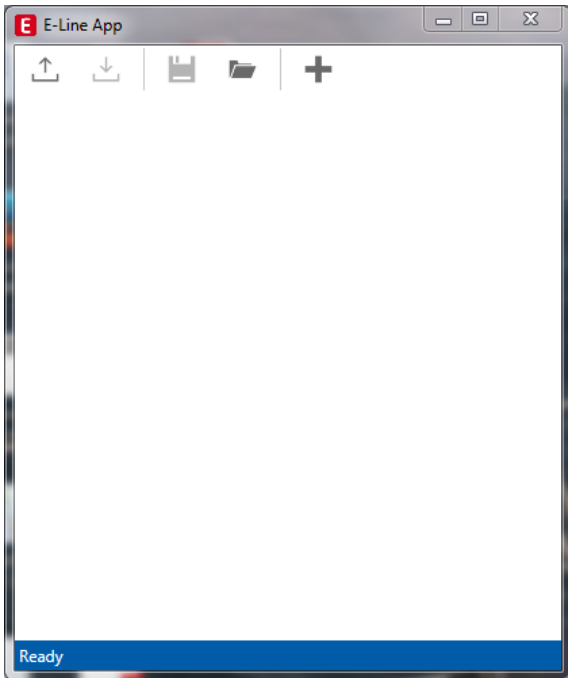

Depending on the application, reset of manually set values is allowed from a panel. To address this requirement, it is possible to deactivate or limit manual operation function.

E-line App device setup

E-Line RIOs support the device setup by a windows application program connected via USB. The installer is available for download from the SBC support page: www.sbc-support.com → E-Line RIO IO Modules.



-  Create a new device configuration
-  Open an existing device configuration
-  Save the current settings as device configuration
-  Upload configuration from the device
-  Download settings to the device

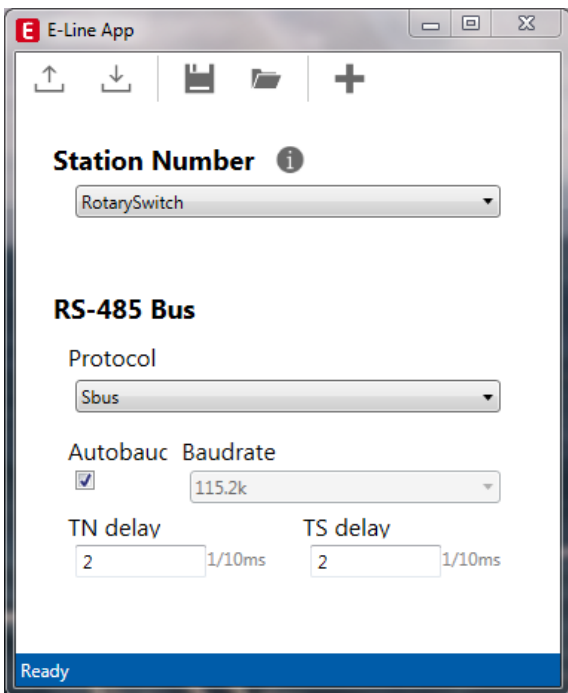

The station number can be set by the rotary switches at the device in the range of 0 ... 98. If the rotary switches are set to position 99 the station number can be defined by the device configuration in a range of 0 ... 253.

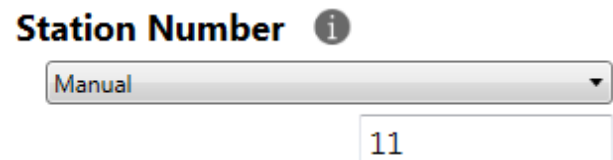

The serial communication protocol can be defined either as S-Bus or Modbus. By default the modules are delivered from factory with S-Bus.

RS-485 Bus

Protocol

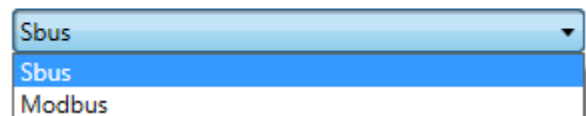

The Baudrate can be defined as automatic detection (default) or set to a specific value. The drop down choice will be available when the check box "Automatic" is unchecked. TN delay and TS delay shall be left at their default values of 2.

S-Bus settings

Autobaud Baudrate

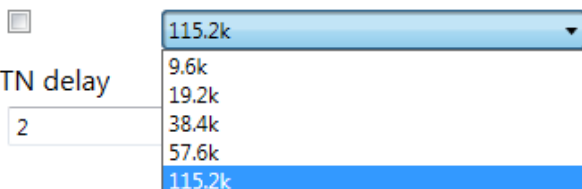

TN delay

2

Modbus settings

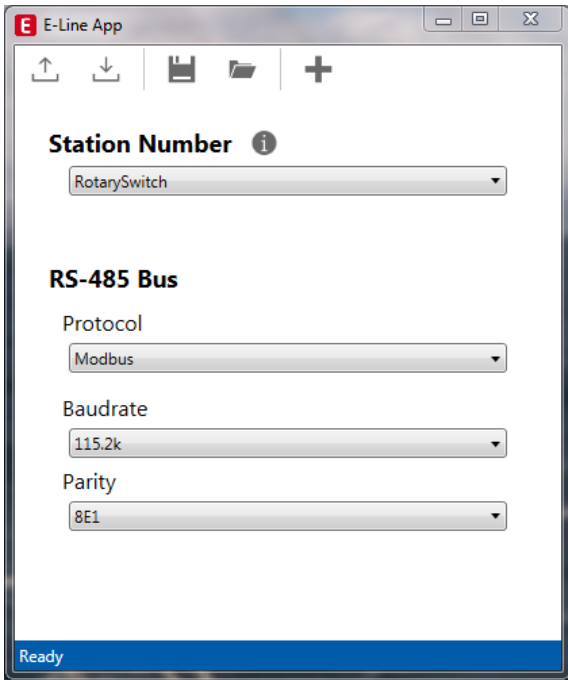

The Baudrate is set by default to 115 k. It can be defined as choice of the list.

Baudrate

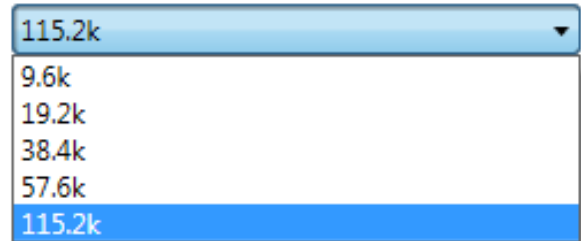

For best interoperability the Parity Mode and number of Stop Bits can also be set.

Parity

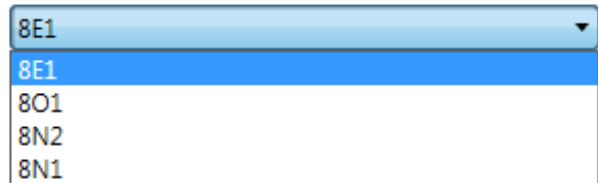

S-Bus communication

S-Bus communication is based on Saia PCD® S-Bus Data Mode. Only the set-up of a unique S-Bus address within the communication line is required to establish a communication between Saia PCD® controllers and E-Line RIO modules. The address can be set by the rotary switches at the front of the module. The baud rate will be learned from the network by factory default. In addition a Windows based application is available for manual parameter setup. Configuration parameters as well as manual override state and value are saved non-volatile. A delay of about one second between a manual state change and none volatile saving has to be taken into consideration.

Device address

- ▶ 0 ... 98 Address is taken from the rotary switches
- ▶ 99 Address is taken from the device configuration. The address is settable with the E-Line configuration software.

Start-up procedure

- ▶ Reboot: All outputs are cleared (Off state)
- ▶ < 1 sec. Output in manual operation are set according to the state before power down.
- ▶ Outputs in automatic mode

Is no telegram received after reboot within the “safe state power-on timeout” the module enters into the safe state mode and sets the outputs according to their configured values.

On reception of a valid command telegram the outputs are controlled by the communication. When no communication update followed within the “safe state com. timeout” the module enters into safe state and sets the outputs according to their configured values.

Usage of the E-Line module specific FBoxes

The usage of the E-Line module specific FBoxes from the E-Line S-Bus Fupla library allows an easy and efficient commissioning of the E-Line RIO.

The FBox allow to define and configure all possible functionalities of the E-Line RIO like manual override permission, usage of safe state mode, behaviour and colour of the LED’s and so on.

In the background, the FBox does use the fast ‘E-Line S-Bus’ protocol for a high speed communication between the master and the RIO.

The image shows three parts of the software interface:

- Left Panel:** A tree view of 'E-Line Devices' with 'EL-PCD1.B1120' selected.
- Middle Panel:** A diagram showing three channel configurations:
 - Channel: S-Bus / EL MST (Inputs: start_SBus, En, Error)
 - ref:Channel: EL-Diag devices (Inputs: start_diagnostic, En, Error)
 - ref:Channel: EL-B1120 (Inputs: start_EL, man_EL, En, Error, Man, Diag)
- Right Panel:** The 'Properties' window for 'FBox : EL-PCD1.B1120'.

General	
(Name)	
Reference	Channel
Comment	
Adjust Variables	
S-Bus address	1
Comm interval inputs/outputs	On each cycle
Comm interval manual override	On each cycle
Diagnostic:	
Up/download configurations:	
Manual value access	
Manual override permission	HW + S-Bus restricted
Advanced settings	
Safe state activ. timeout [s]	0.000
Digital outputs:	
Safe state DO 0	Unchanged
Safe state DO 1	Unchanged
Safe state DO 2	Unchanged
Safe state DO 3	Unchanged
Static Symbols	
Download this device	EChannel.PCD1_B1020_0.Parameters.SF_ButtonD...
Upload this device	EChannel.PCD1_B1020_0.Parameters.SF_ButtonU...
Download this device (view)	EChannel.PCD1_B1020_0.Parameters.SF_Downlo...
Upload this device (view)	EChannel.PCD1_B1020_0.Parameters.SF_Upload...
Advanced Info	
Title	EL-PCD1.B1020
Macro Name	_ELINE_B1020
FBox ID	17
Status	Active
Extra Info	
Logical group	E-Line S-Bus.Mixed Rio
Version in use	V6.0.000
Version in Library	V6.0.000

S-Bus communication

Direct access to the RIO media with standard S-Bus send and receive telegrams

The following chapter describes the media and parameter mapping to Registers and Flags for individual programming. For efficient PCD programming the E-Line RIO FBox family and templates are suitable for most applications. Only individual programming (e.g. Instruction List) require standard S-Bus communication.

Digital inputs

Input	Input Value	Read/Write
Digital input 0	Flag 0	R
Digital input 1	Flag 1	R
Digital input 2	Flag 2	R
Digital input 3	Flag 3	R
Digital input 4	Flag 4	R
Digital input 5	Flag 5	R
Digital input 6	Flag 6	R
Digital input 7	Flag 7	R

Digital inputs

Input	Input Value	Read/Write
Digital input 8	Flag 8	R
Digital input 9	Flag 9	R
Digital input 10	Flag 10	R
Digital input 11	Flag 11	R
Digital input 12	Flag 12	R
Digital input 13	Flag 13	R
Digital input 14	Flag 14	R
Digital input 15	Flag 15	R

Relay outputs

Output	Output Value	Read/Write	Manual override Communication	Read/Write*	Manual override Local	Read/Write**
Relay output 0	Flag 30	RW	Register 90	RW	Register 94	R
Relay output 1	Flag 31	RW	Register 91	RW	Register 95	R
Relay output 2	Flag 32	RW	Register 92	RW	Register 96	R
Relay output 3	Flag 33	RW	Register 93	RW	Register 97	R

* Writable only if S-Bus permission is set in the configuration, otherwise write has no effect

** Writing to these registers has no effect. Used only if hardware permission is set in the configuration

Normal operation: The outputs are set according the flag set by the communication.

Manual operation: The output are set according to the manual command, the communication flags are ignored.

Safe State: In case of a broken communication, a safe state value can be applied, see table Safe State Configuration.

Register format for manual override via S-Bus (Reg. 90 ... 93):

- Bit 0 Current output value
- Bit 30 1: output is driven in manual override by S-Bus
- Bit 31 1: output is driven in manual override by local push buttons

Register format for local manual override (Reg. 94 ... 97):

- Bit 0 Current output value
- Bit 31 1: output is driven in manual override by local push buttons

LED Configuration

LED Relay output 0	Register 300	RW
LED Relay output 1	Register 301	RW
LED Relay output 2	Register 302	RW
LED Relay output 3	Register 303	RW
LED Digital input 0	Register 330	RW
LED Digital input 1	Register 331	RW
LED Digital input 2	Register 332	RW
LED Digital input 3	Register 333	RW
LED Digital input 4	Register 334	RW
LED Digital input 5	Register 335	RW
LED Digital input 6	Register 336	RW
LED Digital input 7	Register 337	RW
...	...	RW
LED Digital input 15	Register 345	RW

Register format:

Bit 0 ... 7	I/O state Low	LED colour
Bit 8 ... 15	I/O state Low	LED blink code
Bit 16 ... 23	I/O state High	LED colour
Bit 24 ... 31	I/O state High	LED blink code

LED colour	0: Off 1: Red 2: Green 3: Orange (red + green)
------------	---

LED blink code	0: No blink 1: Slow blinking (0.5 flashes per second) 2: Fast blinking (2 flashes per second)
----------------	---

Factory default: Low: off, High: LED colour 2 (green), no blink

The LEDs can be configured individually depending on the I/O state in colour and blink code.

S-Bus communication

Configuration for safe state and manual override

Output	Safe State Enable	Read/Write	Safe State Value	Read/Write
Relay output 0	Flag 320	RW	Flag 350	RW
Relay output 1	Flag 321	RW	Flag 351	RW
Relay output 2	Flag 322	RW	Flag 352	RW
Relay output 3	Flag 323	RW	Flag 353	RW
Communication safe state enable default 0 (disabled)			Flag 400	RW
Power-On safe state enable default 0 (disabled)			Flag 401	RW
Power-On safe state timeout [ms], Valid values 1000 ... 100.000.000, default 30.000			Register 590	RW
Communication safe state timeout [ms] Valid values 1000 ... 100.000.000, default 15.000			Register 591	RW
Manual operation mode Bit 0: Disabled Bit 1: Remote control limited*, default 1 Bit 2: Local operation enabled, default 1 Bit 3: Remote control unlimited*, default 0 Bits can be combined to enable remote and local operation			Register 592	RW

* If manual operation is locally activated at the module, the output value and manual state cannot be set/reset remotely

Manual operation mode:

- ▶ Disabled (0)
- ▶ Local operation only (4, Bit 2 set)
- ▶ Local operation enabled, remote limited (6, Bit 1 and 2 set), default
- ▶ Local and remote operation enabled (12, Bit 2 and 3 set)
- ▶ Remote operation only, local operation disabled (8, Bit 3 set)

The safe state enable flag and the safe state value are combined in the following way:

- Setting the enable flag to 0 keep the output value unchanged in case of safe state occurrence.
- Setting the enable flag to 1 writes the safe state value in case of safe state occurrence.

Device Information

Firmware version (Decimal xyzzyz, 10802 → 1.08.02)	Register 600	R
Number of supported registers	Register 601	R
Number of supported flags	Register 602	R
Product type (ASCII String)***	Register 605 ... 608	R
Hardware version (Hex)	Register 609	R
Serial number (Hex)	Register 611 ... 612	R
Communication protocol (1:S-Bus Slave, 3:Modbus)	Register 620	R
Communication baud rate	Register 621	R
Communication auto baud enable (0:disabled, 1:enabled)	Register 622	R
Communication TN delay *	Register 623	R
Communication TS delay **	Register 624	R
Communication module address	Register 626	R

* Time in 0.1 ms (e.g. 2 means 200 us) before setting activation of RS-485 line driver send mode (only used for S-Bus slave protocol)

** Time in 0.1 ms (e.g. 2 means 200 us) before sending the first character after line driver activation (only used for S-Bus slave protocol)

*** The four registers contain the ASCII characters of the product type.

E.g. for PCD1.A2000-A20:

0605: 50434431H 0606: 2E413230H 0607: 30302D41H 0608: 32300000H

Modbus communication

Modbus fulfils the requirements for standard communication protocols. It is based on Modbus RTU. The Windows based configuration software is required to enable and set up the Modbus communication parameters. The device address can be set up with the rotary switches at the front of the module. Configuration parameters as well as manual override state and value are saved non-volatile. A delay of about one second between a manual state change and non-volatile saving has to be taken into consideration.

Device address

- ▶ 0 ... 98 Address is taken from the rotary switches
- ▶ 99 Address is taken from the device configuration. The address is settable with the E-Line configuration software.

Start-up procedure

- ▶ Reboot: All outputs are cleared (Off state)
- ▶ <1 sec. Output in manual operation are set according to the state before power down.
- ▶ Outputs in automatic mode
 - Is no telegram received after reboot within the "safe state power-on timeout" the module enters as will into the safe state mode and sets the outputs according to their configured values.
 - On reception of a valid command telegram the outputs are controlled by the communication. When no communication update followed within the "safe state com. timeout" the module enters into safe state and sets the outputs according to their configured values.

The following chapter describes the media and parameter mapping to Registers and Flags (=Coils).

Supported Modbus services:

- ▶ Function code 1 (read outputs)
- ▶ Function code 3 (read registers)
- ▶ Function code 15 (write multiple outputs)
- ▶ Function code 16 (write multiple registers)

Read coils

Request							
Address	Function	Start Address		Number of coils to read		CRC	
0 ... 254	1	High-Byte	Low-Byte	High-Byte	Low-Byte	High-Byte	Low-Byte

Reply							
Address	Function	No. of Byte	Data			CRC	
0 ... 254	1	0 ... 256	Coil 0 ... 7	Coil 8 ... 15	...	High-Byte	Low-Byte

Write coils

Request										
Address	Function	Start Address		Number of Coils to write		Coil data			CRC	
0 ... 254	15	High-Byte	Low-Byte	High-Byte	Low-Byte	No. of Bytes	Coil 0 ... 7	...	High-Byte	Low-Byte

Reply							
Address	Function	Start Address		Number of written Coils		CRC	
0 ... 254	15	High-Byte	Low-Byte	High-Byte	Low-Byte	High-Byte	Low-Byte

Read register

Request							
Address	Function	Start Address		No. of Register to read		CRC	
0 ... 254	3	High-Byte	Low-Byte	High-Byte	Low-Byte	High-Byte	Low-Byte

Reply							
Address	Function	No. of Byte	Register Start Addr + 0	Addr + n	CRC		
0 ... 254	3	0 ... 256	High-Byte	Low-Byte	...	High-Byte	Low-Byte

Write register

Request											
Address	Function	Start Address		No. of Registers		No. of Bytes	Data Word: Start Addr + 0		Addr + n	CRC	
0 ... 254	16	High-Byte	Low-Byte	High-Byte	Low-Byte	2 ... 256	Low-Byte	High-Byte	...	High-Byte	Low-Byte

Reply							
Address	Function	Start Address		No of written Registers		CRC	
0 ... 254	16	High-Byte	Low-Byte	High-Byte	Low-Byte	High-Byte	Low-Byte

The CRC has to be calculated over all telegram bytes starting with address field up to the last data byte. The CRC has to be attached to the data. Please find an example at the appendix of this document. For more details, please refer the publicly available Modbus documentation www.modbus.org.

Modbus communication

Digital inputs

Input	Input Value	Read/Write
Digital input 0	Flag 0	R
Digital input 1	Flag 1	R
Digital input 2	Flag 2	R
Digital input 3	Flag 3	R
Digital input 4	Flag 4	R
Digital input 5	Flag 5	R
Digital input 6	Flag 6	R
Digital input 7	Flag 7	R
Digital input 8	Flag 8	R
Digital input 9	Flag 9	R
Digital input 10	Flag 10	R
Digital input 11	Flag 11	R
Digital input 12	Flag 12	R
Digital input 13	Flag 13	R
Digital input 14	Flag 14	R
Digital input 15	Flag 15	R

Relay outputs Digital outputs

Output	Output Value	Read/Write	Manual override Communication	Read/Write*	Manual override Local	Read/Write**
Relay output 0	Flag 30	RW	Value Reg. 180 Enable Reg. 181	RW	Value Reg. 188 Enable Reg. 189	R
Relay output 1	Flag 31	RW	Value Reg. 182 Enable Reg. 183	RW	Value Reg. 190 Enable Reg. 191	R
Relay output 2	Flag 32	RW	Value Reg. 184 Enable Reg. 185	RW	Value Reg. 192 Enable Reg. 193	R
Relay output 3	Flag 33	RW	Value Reg. 186 Enable Reg. 187	RW	Value Reg. 194 Enable Reg. 195	R

* Writable only if Modbus permission is set in the configuration, otherwise write has no effect

**Writing to these registers has no effect. Used only if hardware permission is set in the configuration

Normal operation: The outputs are set according the flag set by the communication.

Manual operation: The output are set according to the manual command, the communication flags are ignored.

Safe State: In case of a broken communication, a safe state value can be applied, see table Safe State Configuration.

Register format for manual override via Modbus (Reg. 180 ... 187):

Bit 0 Current output value

Enable Reg. Bit 14 1: output is driven in manual override by Modbus

Enable Reg. Bit 15 1: output is driven in manual override by local push buttons

Register format for local manual override (Reg. 188 ... 195):

Value Reg. Bit 0 Current output value

Enable Reg. Bit 15 1: output is driven in manual override by local push buttons

Modbus communication

LED Configuration

LED Relay output 0	Output L, Reg. 600 Output H, Reg. 601	RW
LED Relay output 1	Output L, Reg. 602 Output H, Reg. 603	RW
LED Relay output 2	Output L, Reg. 604 Output H, Reg. 605	RW
LED Relay output 3	Output L, Reg. 606 Output H, Reg. 607	RW
LED Digital input 0	Output L, Reg. 660 Output H, Reg. 661	RW
LED Digital input 1	Output L, Reg. 662 Output H, Reg. 663	RW
LED Digital input 2	Output L, Reg. 664 Output H, Reg. 665	RW
LED Digital input 3	Output L, Reg. 666 Output H, Reg. 667	RW
LED Digital input 4	Output L, Reg. 668 Output H, Reg. 669	RW
LED Digital input 5	Output L, Reg. 670 Output H, Reg. 671	RW
LED Digital input 6	Output L, Reg. 672 Output H, Reg. 673	RW
LED Digital input 7	Output L, Reg. 674 Output H, Reg. 675	RW
LED Digital input 8	Output L, Reg. 676 Output H, Reg. 677	RW
LED Digital input 9	Output L, Reg. 678 Output H, Reg. 679	RW
LED Digital input 10	Output L, Reg. 680 Output H, Reg. 681	RW
LED Digital input 11	Output L, Reg. 682 Output H, Reg. 683	RW
LED Digital input 12	Output L, Reg. 684 Output H, Reg. 685	RW
LED Digital input 13	Output L, Reg. 686 Output H, Reg. 687	RW
LED Digital input 14	Output L, Reg. 688 Output H, Reg. 689	RW
LED Digital input 15	Output L, Reg. 690 Output H, Reg. 691	RW

Register format:

Output L, Bit 0 ... 7	I/O state Low	LED colour
Output L, Bit 8 ... 15	I/O state Low	LED blink code
Output H, Bit 0 ... 7	I/O state High	LED colour
Output H, Bit 8 ... 15	I/O state High	LED blink code

LED colour

0: Off
1: Red
2: Green
3: Orange (red + green)

LED blink code

0: No blink
1: Slow blinking (0.5 flashes per second)
2: Fast blinking (2 flashes per second)

Factory default:

Low: off,
High: LED colour 2 (green), no blink

The LEDs can be configured individually depending on the I/O state in colour and blink code.

Modbus communication

Configuration for safe state and manual override

Output	Safe State Enable	Read/Write	Safe State Value	Read/Write
Relay Output 0	Flag 320	RW	Flag 350	RW
Relay Output 1	Flag 321	RW	Flag 351	RW
Relay Output 2	Flag 322	RW	Flag 352	RW
Relay Output 3	Flag 323	RW	Flag 353	RW
Communication safe state enable default 0 (disabled)			Flag 400	RW
Power-On safe state enable default 0 (disabled)			Flag 401	RW
Power-On safe state timeout [ms], Valid values 1000 ... 100.000.000, default 30.000			Reg. 1180, 1181	RW
Communication safe state timeout [ms] Valid values 1000 ... 100.000.000, default 15.000			Reg. 1182, 1183	RW
Manual operation mode Bit 0: Disabled Bit 1: Remote control limited*, default 1 Bit 2: Local operation enabled, default 1 Bit 3: Remote control unlimited*, default 0 Bits can be combined to enable remote and local operation			Register 1184	RW

* If manual operation is locally activated at the module, the output value and manual state cannot be set/reset remotely

Manual operation mode:

- ▶ Disabled (0)
- ▶ Local operation only (4, Bit 2 set)
- ▶ Local operation enabled, remote limited (6, Bit 1 and 2 set), default
- ▶ Local and remote operation enabled (12, Bit 2 and 3 set)
- ▶ Remote operation only, local operation disabled (8, Bit 3 set)

The safe state enable flag and the safe state value are combined in the following way:

- Setting the enable flag to 0 keep the output value unchanged in case of safe state occurrence.
- Setting the enable flag to 1 writes the safe state value in case of safe state occurrence.

Device Information

Firmware version (Decimal xyzzyz, 10802 → 1.08.02)	Register 1200	R
Number of supported registers	Register 1202	R
Number of supported flags	Register 1204	R
Product type (ASCII String)*	Register 1210 ... 1217	R
Hardware version (Hex)	Register 1218	R
Serial number (Hex)	Register 1222 ... 1224	R
Communication protocol (1: S-Bus Slave, 3: Modbus)	Register 1240	R
Communication baud rate	Register 1242	R
Communication auto baud enable (0:disabled, 1:enabled)	Register 1244	R
Communication Mode 0: 8,E,1; 1: 8,O,1; 2: 8,N,2; 3: 8,N,1	Register 1250	R
Communication module address	Register 1252	R

* The eight registers contain the ASCII characters of the product type.
E.g. for PCD1.A2000-A20:
1210...1217: 5043H | 4431H | 2E41H | 3230H | 3030H | 2D41H | 3230H | 0000H

CRC Generation Example

(Source: http://modbus.org/docs/PI_MBUS_300.pdf, the following content of this page is copied from the referenced document. In case of any questions, please check out the original source)

The function takes two arguments: unsigned char *puchMsg; A pointer to the message buffer containing binary data to be used for generating the CRC unsigned short usDataLen; The quantity of bytes in the message buffer. The function returns the CRC as a type unsigned short.

CRC Generation Function

```
unsigned short CRC16(puchMsg, usDataLen) ;
unsigned char *puchMsg ;                               /* message to calculate CRC upon */
unsigned short usDataLen ;                             /* quantity of bytes in message */
{
    unsigned char uchCRCHi = 0xFF ;                   /* high byte of CRC initialized */
    unsigned char uchCRCLo = 0xFF ;                   /* low byte of CRC initialized */
    unsigned uIndex ;                                  /* will index into CRC lookup table */
    while (usDataLen--)>0                             /* pass through message buffer */
    {
        uIndex = uchCRCHi ^ *puchMsg++;               /* calculate the CRC */
        uchCRCHi = uchCRCLo ^ auchCRCHi[uIndex];
        uchCRCLo = auchCRCLo[uIndex];
    }
    return (uchCRCHi << 8 | uchCRCLo);
}
```

High-Order Byte Table

```
/* Table of CRC values for high-order byte */
static unsigned char auchCRCHi[] = {
0x00, 0xC1, 0x81, 0x40, 0x01, 0xC0, 0x80, 0x41, 0x01, 0xC0, 0x80, 0x41, 0x00, 0xC1, 0x81, 0x40,
0x01, 0xC0, 0x80, 0x41, 0x00, 0xC1, 0x81, 0x40, 0x00, 0xC1, 0x81, 0x40, 0x01, 0xC0, 0x80, 0x41,
0x01, 0xC0, 0x80, 0x41, 0x00, 0xC1, 0x81, 0x40, 0x00, 0xC1, 0x81, 0x40, 0x01, 0xC0, 0x80, 0x41,
0x00, 0xC1, 0x81, 0x40, 0x01, 0xC0, 0x80, 0x41, 0x01, 0xC0, 0x80, 0x41, 0x00, 0xC1, 0x81, 0x40,
0x01, 0xC0, 0x81, 0x40, 0x01, 0xC0, 0x80, 0x41, 0x01, 0xC0, 0x80, 0x41, 0x00, 0xC1, 0x81, 0x40,
0x00, 0xC1, 0x81, 0x40, 0x01, 0xC0, 0x80, 0x41, 0x01, 0xC0, 0x80, 0x41, 0x00, 0xC1, 0x81, 0x40,
0x01, 0xC0, 0x80, 0x41, 0x00, 0xC1, 0x81, 0x40, 0x00, 0xC1, 0x81, 0x40, 0x01, 0xC0, 0x80, 0x41,
0x01, 0xC0, 0x80, 0x41, 0x00, 0xC1, 0x81, 0x40, 0x00, 0xC1, 0x81, 0x40, 0x01, 0xC0, 0x80, 0x41,
0x01, 0xC0, 0x81, 0x40, 0x01, 0xC0, 0x80, 0x41, 0x01, 0xC0, 0x80, 0x41, 0x00, 0xC1, 0x81, 0x40,
0x00, 0xC1, 0x81, 0x40, 0x01, 0xC0, 0x80, 0x41, 0x01, 0xC0, 0x80, 0x41, 0x00, 0xC1, 0x81, 0x40,
0x01, 0xC0, 0x81, 0x40, 0x01, 0xC0, 0x80, 0x41, 0x01, 0xC0, 0x80, 0x41, 0x00, 0xC1, 0x81, 0x40,
0x01, 0xC0, 0x80, 0x41, 0x00, 0xC1, 0x81, 0x40, 0x01, 0xC0, 0x80, 0x41, 0x01, 0xC0, 0x80, 0x41,
0x01, 0xC0, 0x80, 0x41, 0x00, 0xC1, 0x81, 0x40, 0x01, 0xC0, 0x80, 0x41, 0x01, 0xC0, 0x80, 0x41,
0x00, 0xC1, 0x81, 0x40, 0x01, 0xC0, 0x80, 0x41, 0x01, 0xC0, 0x80, 0x41, 0x00, 0xC1, 0x81, 0x40 };
```

Low-Order Byte Table

```
/* Table of CRC values for low-order byte */
static char auchCRCLo[] = {
0x00, 0xC0, 0xC1, 0x01, 0xC3, 0x03, 0x02, 0xC2, 0xC6, 0x06, 0x07, 0xC7, 0x05, 0xC5, 0xC4, 0x04,
0xCC, 0x0C, 0x0D, 0xCD, 0x0F, 0xCF, 0xCE, 0x0E, 0x0A, 0xCA, 0xCB, 0x0B, 0xC9, 0x09, 0x08, 0xC8,
0xD8, 0x18, 0x19, 0xD9, 0x1B, 0xDB, 0xDA, 0x1A, 0x1E, 0xDE, 0xDF, 0x1F, 0xDD, 0x1D, 0x1C, 0xDC,
0x14, 0x04, 0x05, 0x15, 0x07, 0x17, 0x16, 0x06, 0xD2, 0x12, 0x13, 0x03, 0x11, 0x01, 0xD0, 0x10,
0xF0, 0x30, 0x31, 0xF1, 0x33, 0xF3, 0xF2, 0x32, 0x36, 0xF6, 0xF7, 0x37, 0xF5, 0x35, 0xF4, 0x34,
0x3C, 0xFC, 0xFD, 0x3D, 0xFF, 0x3F, 0x3E, 0xFE, 0xFA, 0x3A, 0x3B, 0xFB, 0x39, 0x38, 0xF8, 0x38,
0x28, 0xE8, 0xE9, 0x29, 0xEB, 0x2B, 0x2A, 0xEA, 0xEE, 0x2E, 0x2F, 0xEF, 0x2D, 0xED, 0xEC, 0x2C,
0xE4, 0x24, 0x25, 0xE5, 0x27, 0xE7, 0xE6, 0x26, 0x22, 0xE2, 0xE3, 0x23, 0xE1, 0x21, 0x20, 0xE0,
0xA0, 0x60, 0x61, 0xA1, 0x63, 0xA3, 0xA2, 0x62, 0x66, 0xA6, 0xA7, 0x67, 0xA5, 0x65, 0x64, 0xA4,
0x6C, 0xAC, 0xAD, 0x6D, 0xAF, 0x6F, 0x6E, 0xAE, 0xAA, 0x6A, 0x6B, 0xAB, 0x69, 0xA9, 0xA8, 0x68,
0x78, 0xB8, 0xB9, 0x79, 0xBB, 0x7B, 0x7A, 0xBA, 0xBE, 0x7E, 0x7F, 0xBF, 0x7D, 0xBD, 0xBC, 0x7C,
0xB4, 0x74, 0x75, 0xB5, 0x77, 0xB7, 0xB6, 0x76, 0x72, 0xB2, 0xB3, 0x73, 0xB1, 0x71, 0x70, 0xB0,
0x50, 0x90, 0x91, 0x51, 0x93, 0x53, 0x52, 0x92, 0x96, 0x56, 0x57, 0x97, 0x55, 0x95, 0x94, 0x54,
0x9C, 0x5C, 0x5D, 0x9D, 0x5F, 0x9F, 0x9E, 0x5E, 0x5A, 0x9A, 0x9B, 0x5B, 0x99, 0x59, 0x58, 0x98,
0x88, 0x48, 0x49, 0x89, 0x4B, 0x8B, 0x8A, 0x4A, 0x4E, 0x8E, 0x8F, 0x4F, 0x8D, 0x4D, 0x4C, 0x8C,
0x44, 0x84, 0x85, 0x45, 0x87, 0x47, 0x46, 0x86, 0x82, 0x42, 0x83, 0x41, 0x81, 0x80, 0x40 };
```



NOTE

Extra low voltages (ELV) or secure low voltages are voltages up to 50 Volts.



NOTE

Low voltages are voltages between 50 ... 250 Volts.

INSTALLATION DIRECTION FOR SWITCHING LOWER VOLTAGES

For reasons of safety it is not allowed that extra low voltages and low voltages are connected to two adjacent relay contacts. Neither different phases may be connected to two adjacent relay contacts. But a relay contact between them can be left empty.



If a Saia PCD® system module is connected to a low voltage approved components for this voltage have to be used for all elements which are galvanically connected to this system.

When using low voltage, all connections to the relay contacts, which are connected to the same circuit, must be protected by a common fuse.

The individual load circuits, on the other hand, may be protected individually by a fuse.

Wiring example with fuses

Relay changeover

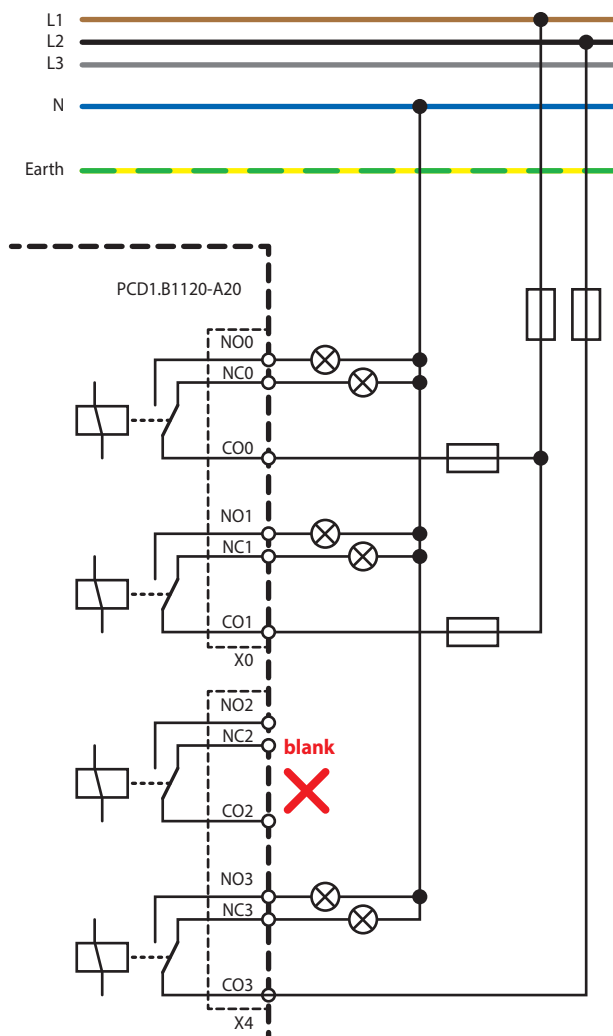

Switching Inductive Loads

Due to the physical properties of the inductance, noiseless shutdown of the inductance is not possible. These interferences must be minimised as much as possible. Regardless of whether the Saia PCD® is immune to these interferences, other devices may still be impaired.

It should also be noted that, as part of EU standard harmonisation, the EMC standards have been valid since 1996 (EMC Directive 89/336/EC). For this reason, two principles can be observed:

- THE SUPPRESSION OF INDUCTIVE LOADS IS ABSOLUTELY NECESSARY!
- INTERFERENCE SHOULD BE ELIMINATED AT THE INTERFERENCE SOURCE IF POSSIBLE!

The relay contacts on the existing module are wired. It is nevertheless recommended to install a suppressor on the load. (Often available as standard components for standardised gates and valves).

When switching DC voltage, it is highly recommended to install a freewheeling diode over the load. This is also the case even if theoretically a resistive load is switched. There is always an inductive share in practice (connection cable, resistor coil, etc.). Please note that the shutdown time is extended here.

($T_a \text{ approx. } L/RL * \sqrt{RL * IL/0.7}$).

The transistor output modules are recommended for DC voltage.

Specifications of the relay manufacturer about the dimensioning of the RC elements

Contact protection circuits:

The purpose of the contact protection circuits is the suppression of the switching arcs ("switching sparks") and thus achieving a longer service life of the contact pieces. Each protection circuit may exhibit advantages and disadvantages. For arc quenching using RC elements, see the figure opposite.

When shutting down load circuits with inductive components (e.g. relay coils and magnet windings), an overvoltage (self-induction voltage) can arise which may be many times higher than the operating voltage and jeopardise the isolation on the load circuit due to the current interruption at the switching contacts. The initial sparks that arise from this lead to rapid wear on the relay contacts. For this reason, the contact protection circuit is particularly important for inductive load circuits. The values for the RC combination can also be determined from the diagram opposite, however the overvoltage (e.g. to be measured with an oscilloscope) arising from the current interruption for the voltage U is to be applied. The current must be calculated based on this voltage and the known resistance at which this was measured.

Only anti-interference capacitors in accordance with VDE 0565 T1 class X2 may be used in suppressors. These capacitors have a high switching capability and are designed for particularly high switching overvoltages. Direct operation on the mains voltage is also possible.

The resistors used must withstand high voltages (pulse strength). Voltage flashovers can arise on the production-related coil cut particularly for low-resistance values. Fixed carbon resistors are therefore used for suppressors in particular. Enamelled wire resistors, however, or cement resistors with a large coil pitch are also suitable.

Specifications of the relay manufacturer about the dimensioning of the RC elements

Dimensioning aid:

The value for C results directly from the current to be switched. The value for the resistance R is calculated by drawing a line through the corresponding points of the I and U curve and the resistance is read at the point of intersection with the R curve.

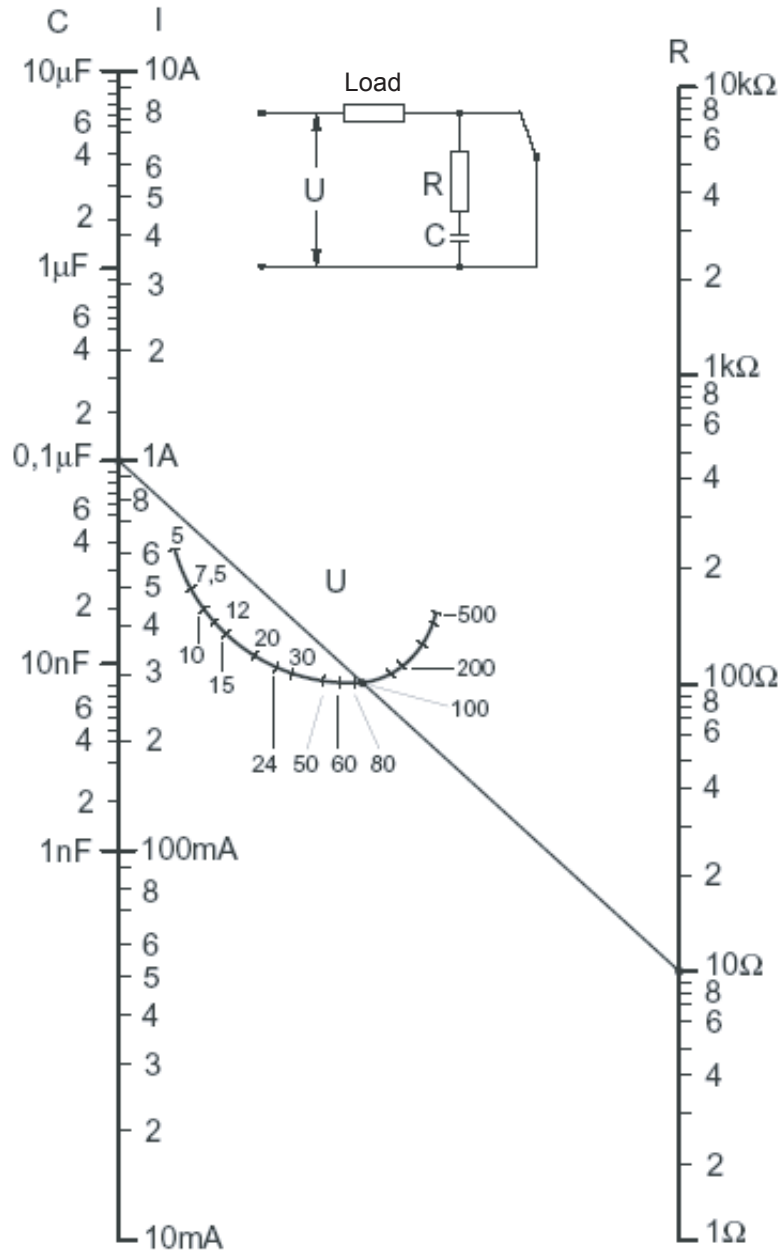

Example:

$U = 100V$ $I = 1A$

C is therefore $0.1 \mu F$

$R = 10 \Omega$ (point of intersection with R-scale)



ATTENTION

These devices must only be installed by a professional electrician, otherwise there is the risk of fire or the risk of an electric shock.



WARNING

Product is not intended to be used in safety critical applications, using it in safety critical applications is unsafe.



WARNING - Safety

The unit is not suitable for the explosion-proof areas and the areas of use excluded in EN 61010 Part 1.



WARNING - Safety

Check compliance with nominal voltage before commissioning the device (see type label). Check that connection cables are free from damage and that, when wiring up the device, they are not connected to voltage.



NOTE

In order to avoid moisture in the device due to condensate build-up, acclimatise the device at room temperature for about half an hour before connecting.



CLEANING

The device can be cleaned in dead state with a dry cloth or cloth soaked in soap solution. Do not use caustic or solvent-containing substances for cleaning.



MAINTENANCE

These devices are maintenance-free. If damaged during transportation or storage, no repairs should be undertaken by the user.



GUARANTEE

Opening the module invalidates the guarantee.



WEEE Directive 2012/19/EC Waste Electrical and Electronic Equipment directive

The product should not be disposed of with other household waste. Check for the nearest authorized collection centers or authorized recyclers. The correct disposal of end-of-life equipment will help prevent potential negative consequences for the environment and human health.



EAC Mark of Conformity for Machinery Exports to Russia, Kazakhstan or Belarus.



PCD1.B1120-A20

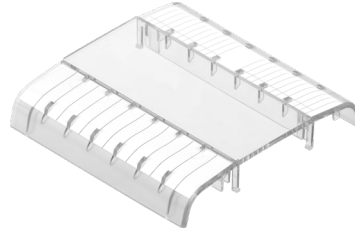

PCD1.K0206-005

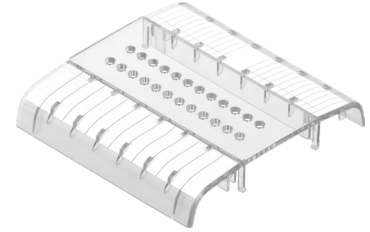

PCD1.K0206-025

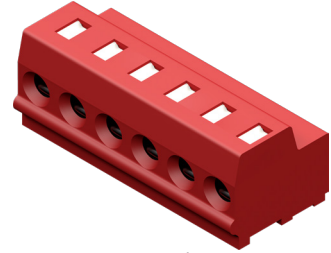

Terminal set
32304321-003-S

Order details

Type	Short description	Description	Weight
PCD1.B1120-A20	RIO E-Line Serie S 16DI, 4Rel	E-Line S-Serie Digital input/output module manual override operating level for all outputs status LED for inputs and outputs supply 24 VDC 16 digital inputs; 24 VDC (source operation) 4 relay changeover 250 VAC / 30 VDC, 5 A (DC1) 1 interface RS-485 (S-Bus and Modbus) 1 USB Service interface	330 g
PCD1.K0206-005	E-Line labelling set 5 × 6 HP*	E-Line cover and labelling set consisting of 5 × covers (6 HP = 105 mm) and labelling sheet for mounting in the automation control cabinet	365 g
PCD1.K0206-025	E-Line labelling set 5 × 6 HP* with holes	E-Line cover and labelling set with holes consisting of 5 × covers (6 HP = 105 mm) with holes for manual override operating level and labelling sheet for mounting in the automation control cabinet	365 g
32304321-003-S	Terminal set	6-pin terminal. Set of 6 terminal blocks	40 g

* Horizontal pitch: 1 HP corresponds to 17.5 mm

Saia-Burgess Controls AG

Rout-Jo-Siffert 4 | 1762 Givisiez, Switzerland
www.saia-pcd.com

support@saia-pcd.com | www.sbc-support.com