

PCD2.W340

Analog input module, 8 channel, 12 bit,
0 ... 2.5 V, 0 ... 10 V, 0 ... 20 mA or Pt/Ni1000

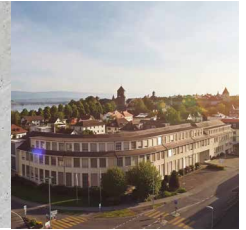

High-speed input module for general use with 8 channels, each with 12 bit resolution.
Different variantes pour tension 0 ... 2,5 V, 0 ... 10 V, current 0 ... 20 mA and the use of different resistance thermometers are available.

Technical specifications

Number of inputs (channels)	8
Signal range	0 ... 2.5 V, 0 ... 10 V, 0 ... 20 mA Pt/Ni 1000
Resolution (representation)	12 bit (0 ... 4095)
Resolution (value of least significant bit(LSB))	2,442 mV (0 ... 10 V) 4,884 μ A (0 ... 20 mA) Pt/Ni 1000 (default) 0,14 ... 0,24 $^{\circ}$ C (Pt 1000 -50 ... +400 $^{\circ}$ C) 0,09 ... 0,12 $^{\circ}$ C (Ni 1000 -50 ... +200 $^{\circ}$ C)
Method of linearization for temperature inputs	by software
Galvanic separation	no
Measuring principle	non-differential, single-ended
Input resistance	U: 200 k Ω / I: 125 Ω
	1,5 mA
Accuracy at 25 $^{\circ}$ C	\pm 0,3 %
Repeating accuracy (under same conditions)	\pm 0,05 %
Temperature error (0 ... +55 $^{\circ}$ C)	\pm 0,2 %
Conversion time A/D	\leq 10 μ s
Overvoltage protection	\pm 50 VDC (permanently)
Overcurrent protection	\pm 40 mA (permanently)
EMV protection	yes

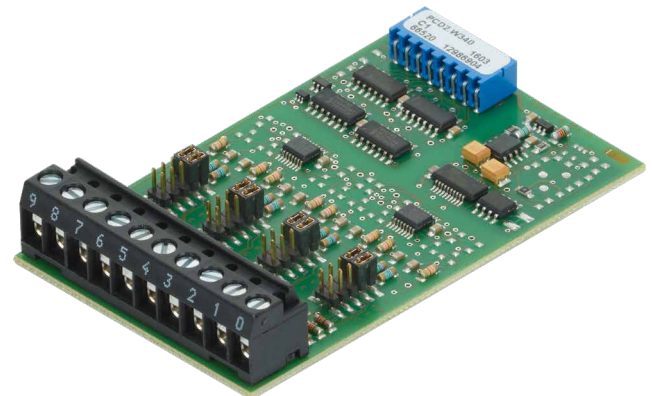

PCD2.W340

Technical specifications

Time constant of input filter	V: typically 7.8 ms C: typically 24.2 ms T: typically 24.2 ms
Internal current consumption (from +5 V bus)	< 8 mA
Internal current consumption (from V+ bus)	< 20 mA
External current consumption	0 mA
Terminals	Pluggable 10-pole spring terminal block for \varnothing up to 1.5 mm ² , plug type L (4 405 4847 0)

Indicators and connections

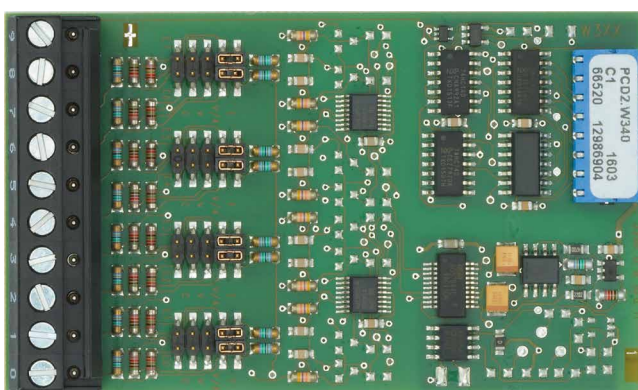

Block schematic

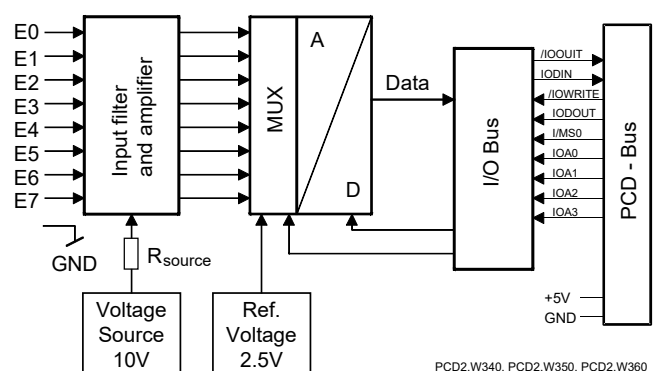

PCD2.W340, PCD2.W350, PCD2.W360

Topology (open housing)

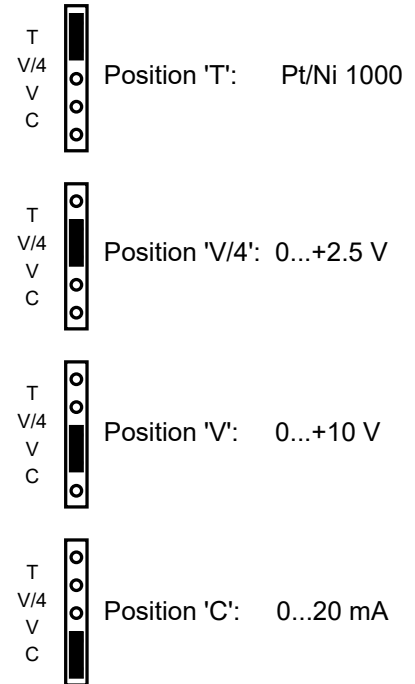
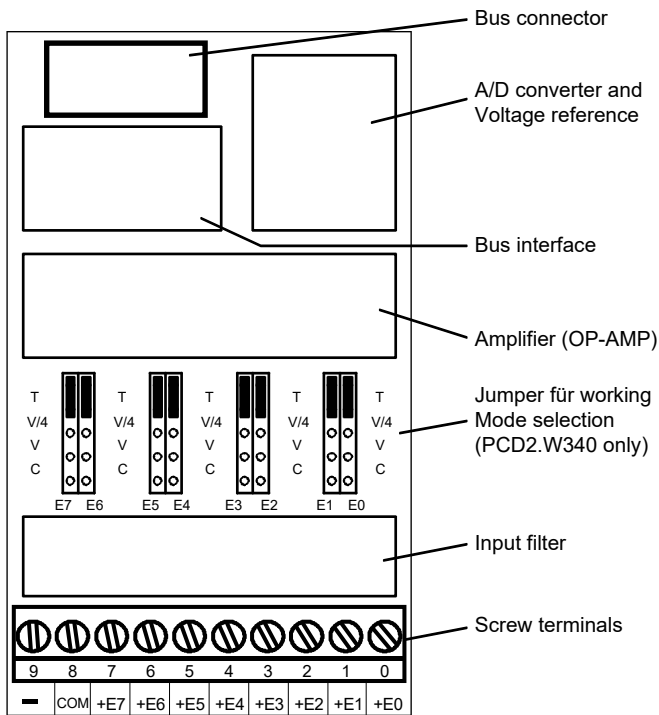

No negative input voltage should be applied on these modules.



Changing the jumpers

On this circuit board there are components that are sensitive to electrostatic discharges.



All inputs set for temperature (position T) must be wired. All unused inputs must be adjusted to current range 'C' or voltage range 'V'.



The reference potentials of signal sources should be wired to a common GND connection ("–" and "COM" terminals). To obtain optimum measurement results, any connection to an earthing bar should be avoided.



If shielded cables are used, the shielding should be connected to an earthing rail.



Input signals with incorrect polarity significantly distort the measurements on the other channels.



Galvanic separation of inputs to CPU, channels themselves not separated.



I/O modules and I/O terminal blocks may only be plugged in and removed when the CPU and the external +24 V are disconnected from the power supply.



Watchdog .. in classic system

The watchdog with his address 255 can influence this module if it is used at the base address 240.

.. in IEC-controller system

is not affected



Further information

This can be found in the Manual "27-600_I/O-modules for PCD1 / PCD2 series and for PCD3".

Connection concept

The voltage input signals are connected directly to the 10-pole terminal block (E0 ... E7 and COM). To minimize the amount of interference coupled into the module via the transmission lines, connection should be made according to the principle explained below.

Connection for 0 ... 10 V

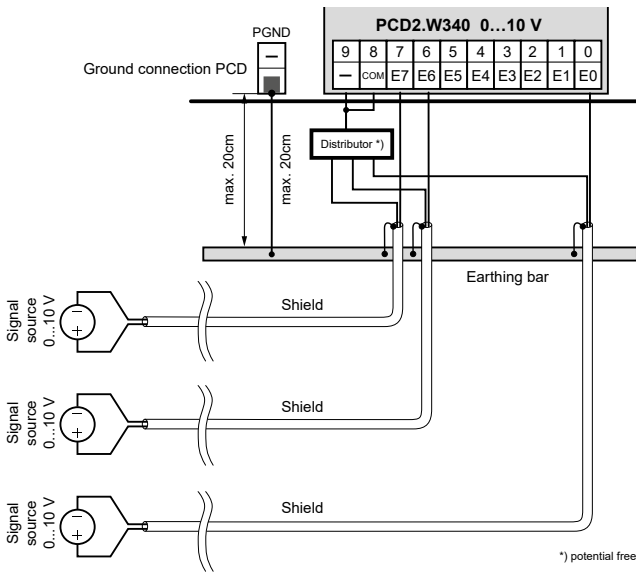

Connection for 0...20 mA with two-wire transducers

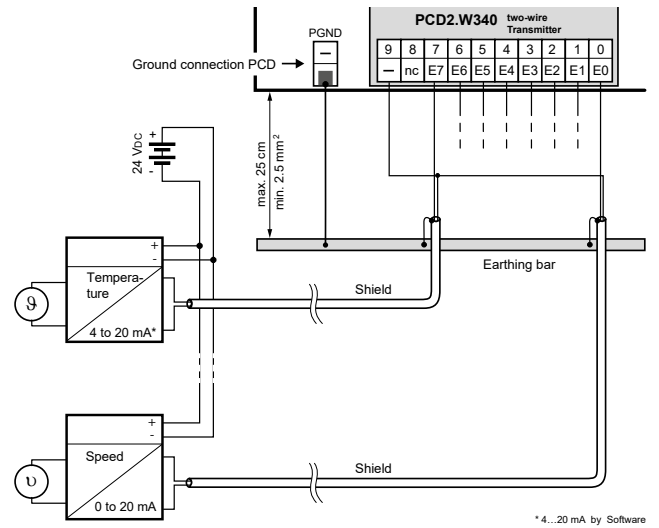

Two-wire transducers need a 24 VDC-supply in the measuring trunk.

Connection mixed operation

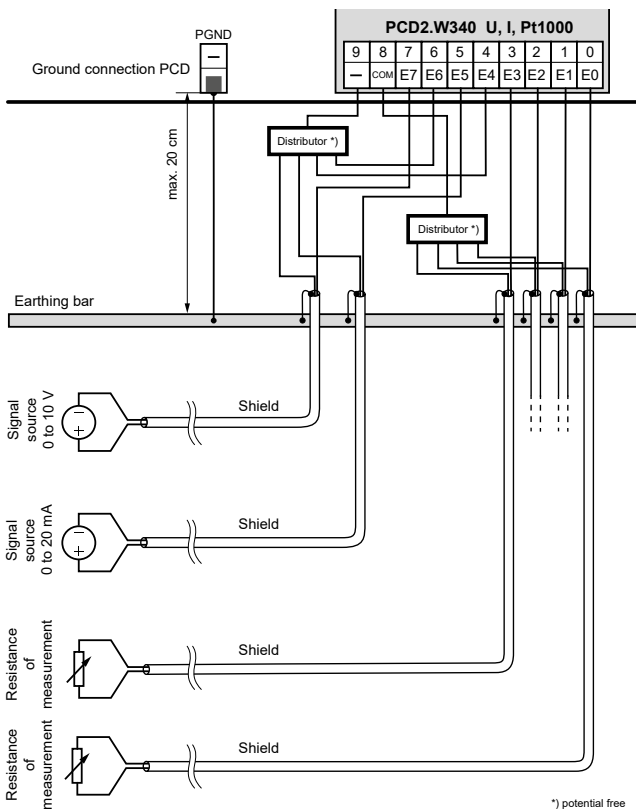

Formulae for temperature measurement

T = temperature in °C

DV = digital value (0...4095)

For Ni1000

Validity: Temperature range - 50 ... + 210 °C

Computational error: ± 0.5 °C

$$T = - 188.5 + \frac{260 \cdot DV}{2616} - 4.676 \cdot 10^{-6} \cdot (DV - 2784)^2$$

For Pt1000

Validity: Temperature range - 50 ... + 400 °C

Computational error: ± 1.5 °C

$$T = - 366.5 + \frac{450 \cdot DV}{2474} + 18.291 \cdot 10^{-6} \cdot (DV - 2821)^2$$

Resistance measurement up to 2.5 kΩ

Special temperature sensors or any other resistances up to 2.5 kΩ can be connected to the PCD3.W340. The digital value can be calculated as follows:

$$DV = \frac{16380 \cdot R}{(7500 + R)}$$

Configuration

Saia PG5® Controls Suite

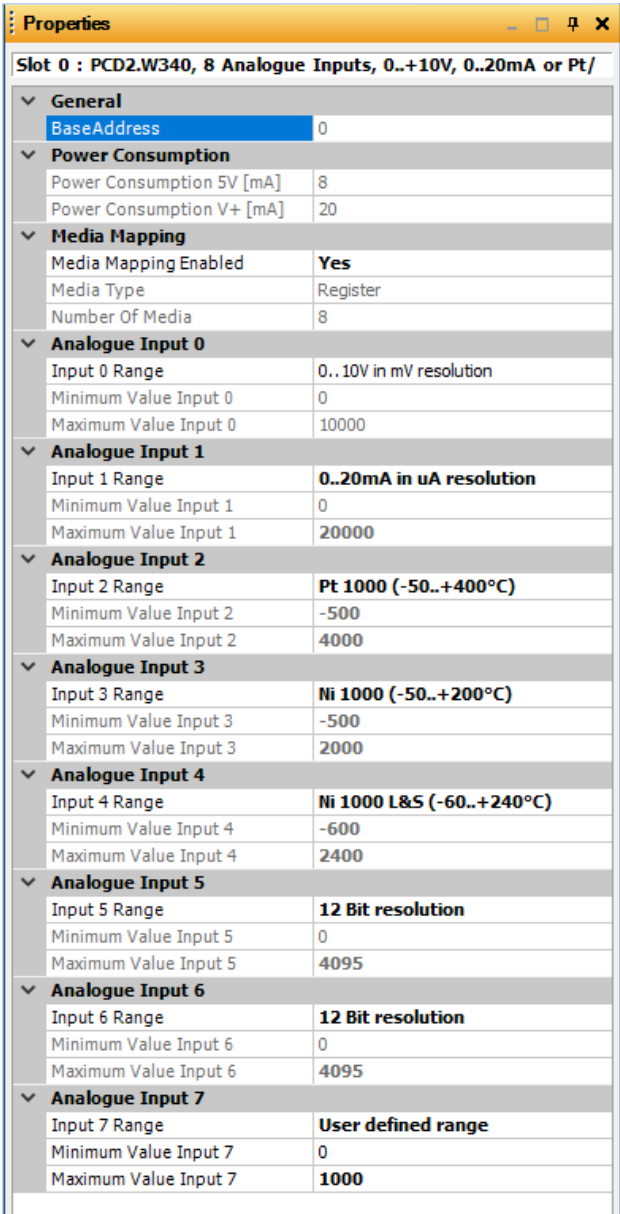
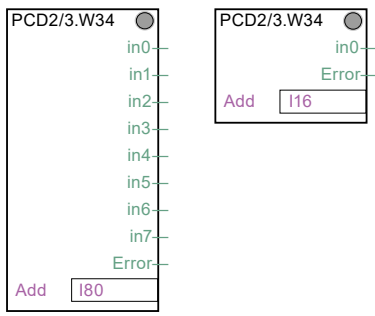
System PCD1 or PCD2	Evaluation
<p>The evaluation is performed by the firmware. It reads the values according to the configuration (Device Configurator or Network Configurator).</p>  <p>Slot 0 : PCD2.W340, 8 Analogue Inputs, 0..+10V, 0..20mA or Pt/</p> <ul style="list-style-type: none"> General <ul style="list-style-type: none"> BaseAddress: 0 Power Consumption <ul style="list-style-type: none"> Power Consumption 5V [mA]: 8 Power Consumption V+ [mA]: 20 Media Mapping <ul style="list-style-type: none"> Media Mapping Enabled: Yes Media Type: Register Number Of Media: 8 Analogue Input 0 <ul style="list-style-type: none"> Input 0 Range: 0..10V in mV resolution Minimum Value Input 0: 0 Maximum Value Input 0: 10000 Analogue Input 1 <ul style="list-style-type: none"> Input 1 Range: 0..20mA in uA resolution Minimum Value Input 1: 0 Maximum Value Input 1: 20000 Analogue Input 2 <ul style="list-style-type: none"> Input 2 Range: Pt 1000 (-50..+400°C) Minimum Value Input 2: -500 Maximum Value Input 2: 4000 Analogue Input 3 <ul style="list-style-type: none"> Input 3 Range: Ni 1000 (-50..+200°C) Minimum Value Input 3: -500 Maximum Value Input 3: 2000 Analogue Input 4 <ul style="list-style-type: none"> Input 4 Range: Ni 1000 L&S (-60..+240°C) Minimum Value Input 4: -600 Maximum Value Input 4: 2400 Analogue Input 5 <ul style="list-style-type: none"> Input 5 Range: 12 Bit resolution Minimum Value Input 5: 0 Maximum Value Input 5: 4095 Analogue Input 6 <ul style="list-style-type: none"> Input 6 Range: 12 Bit resolution Minimum Value Input 6: 0 Maximum Value Input 6: 4095 Analogue Input 7 <ul style="list-style-type: none"> Input 7 Range: User defined range Minimum Value Input 7: 0 Maximum Value Input 7: 1000 	<p>An FBox "PCD2/3.W34" exists for evaluation.</p> <p>FBox for PCD2.W340 (Inputs 0...7 selectable)</p> 

**ATTENTION**

These devices must only be installed by a professional electrician, otherwise there is the risk of fire or the risk of an electric shock.

**WARNING**

Product is not intended to be used in safety critical applications, using it in safety critical applications is unsafe.

**WARNING - SAFETY**

The unit is not suitable for the explosion-proof areas and the areas of use excluded in EN 61010 Part 1.

**WARNING - SAFETY**

Check compliance with nominal voltage before commissioning the device (see type label). Check that connection cables are free from damage and that, when wiring up the device, they are not connected to voltage. Do not use a damaged device !

**NOTE**

In order to avoid moisture in the device due to condensate build-up, acclimatise the device at room temperature for about half an hour before connecting.

**CLEANING**

The device can be cleaned in dead state with a dry cloth or cloth soaked in soap solution. Do not use caustic or solvent-containing substances for cleaning.

**MAINTENANCE**

These devices are maintenance-free. If damaged, no repairs should be undertaken by the user.



Observe this instructions (data sheet) and keep them in a safe place. Pass on the instructions (data sheet) to any future user.

**WEEE Directive 2012/19/EC Waste Electrical and Electronic Equipment directive**

The product should not be disposed of with other household waste. Check for the nearest authorized collection centers or authorized recyclers. The correct disposal of end-of-life equipment will help prevent potential negative consequences for the environment and human health.



EAC Mark of Conformity for Machinery Exports to Russia, Kazakhstan or Belarus.

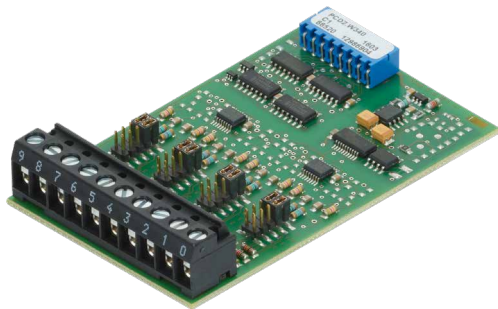

PCD2.W340



4 405 4847 0

Ordering information

Type	Short description	Description	Weight
PCD2.W340	8 analogue inputs, 12 bit. 0...2,5 V, 0...10 V, 0...20 mA or Pt/Ni1000	Universal analogue input module, 8 inputs (channels), resolution 12 bit, signal range 0...2,5 V, 0...10 V, 0...20 mA or Pt/Ni1000. The channels themselves not separated. Connection with pluggable spring terminals, plug-in type L (4 405 4847 0) included	40 g

Ordering information equipment

Type	Short description	Description	Weight
4 405 4847 0	Plug-in, type L	Plug-in I/O spring terminal block, 10-pole up to 1.5 mm ² , labelled 0 ... 9	17 g

Saia-Burgess Controls AG
 Bahnhofstrasse 18 | 3280 Murten, Switzerland
 T +41 26 580 30 00 | F +41 26 580 34 99
 www.saia-pcd.com
 support@saia-pcd.com | www.sbc-support.com

Honeywell | Partner Channel