

PCD3.W340

Analoges Eingangsmodul, 8 Kanäle, 12 Bit,
0 ... 2.5 V, 0 ... 10 V, 0 ... 20 mA, Pt/Ni 1000

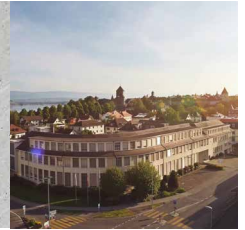

Schnelles Eingangsmodul für den universellen Einsatz mit 8 Kanälen mit je 12 Bit Auflösung.

Es stehen Varianten für Spannung 0 ... 2.5 V, 0 ... 10 V, Strom 0 ... 20 mA sowie für den Anschluss von verschiedene Temperaturmesssonden zur Verfügung.

Technische Daten	
Anzahl Eingänge (Kanäle)	8
Signalbereich	0 ... 2.5 V, 0 ... 10 V, 0 ... 20 mA Pt/Ni 1000
Digitale Darstellung (Auflösung)	12 Bit (0 ... 4095)
Auflösung (Wert des niederwertigsten Bits (LSB))	2.442 mV (0 ... 10 V) 4.884 µA (0 ... 20 mA) Pt/Ni 1000 (Vorgabe) 0.14 ... 0.24 °C (Pt 1000 -50 ... +400 °C) 0.09 ... 0.12 °C (Ni 1000 -50 ... +200 °C)
Linearisierungsmethode für Temperatureingänge:	softwaremässig
Potentialtrennung	nein
Messprinzip	nicht differenziell, single ended
Eingangswiderstand	U: 200 kΩ / I: 125 Ω
Maximaler Messstrom für die Temperaturmesssonden	1.5 mA
Genauigkeit bei 25 °C	± 0.3 %
Wiederholgenauigkeit	± 0.05 %
Temperaturfehler (0 ... +55 °C)	± 0.2 %
Wandlungszeit A/D	≤ 10 µs
Überspannungsschutz	± 50 VDC (permanent)
Überstromschutz ¹⁾	± 40 mA (permanent)
EMV-Schutz	ja



PCD3.W340

Technische Daten	
Zeitkonstante des Eingangsfilters	V: typisch 7.8 ms C: typisch 24.2 ms T: typisch 24.2 ms
Interne Stromaufnahme (ab +5 V Bus)	< 8 mA
Interne Stromaufnahme (ab V+ Bus)	< 20 mA
Externe Stromaufnahme	0 mA
Anschlüsse	Steckbarer 10-poliger Federkraftklemmen-Block für Ø bis 2.5 mm ² , Steckertyp A (4 405 4954 0)

Ansicht und Anschlüsse

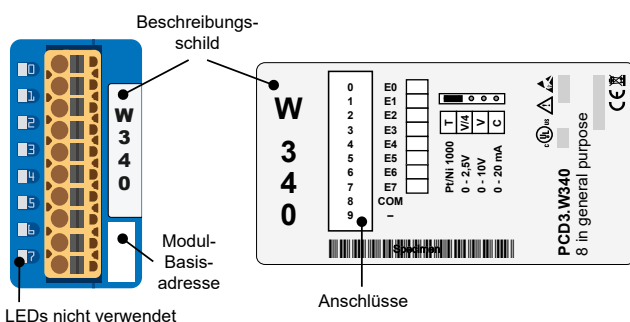

Blockschaltbild

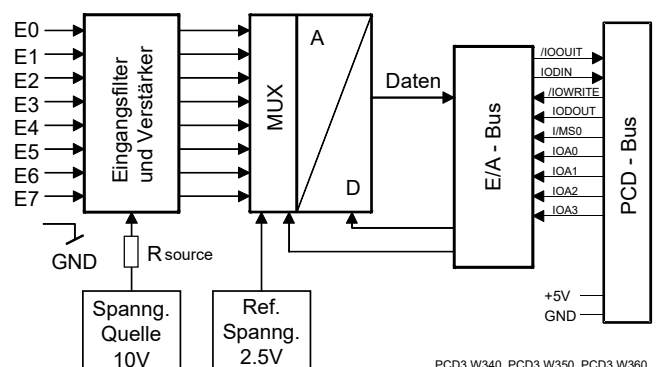

PCD3.W340, PCD3.W350, PCD3.W360

Öffnen bzw. schliessen des Modulgehäuses

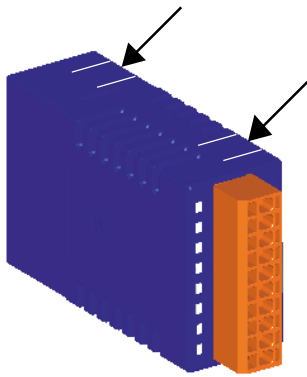

Öffnen

An den beiden schmalen Oberflächen des Gehäuses befinden sich je zwei Snap-in Laschen. Diese zuerst auf der einen Seite, dann auf der anderen mit den Fingernägeln leicht anheben und die beiden Gehäuseteile von einander nehmen.

Schliessen

Zum Schliessen des Gehäuses das Unterteil auf eine ebene Fläche (Tisch etc.) legen. Sicherstellen, dass die Leiterplatte exakt in diesem Gehäuseteil liegt. Oberteil auf das Unterteil drücken bis die Snap-in Laschen hörbar einrasten. Sicherstellen, dass alle vier Laschen korrekt eingeschnappt sind.

Layout (geöffnetes Gehäuse)

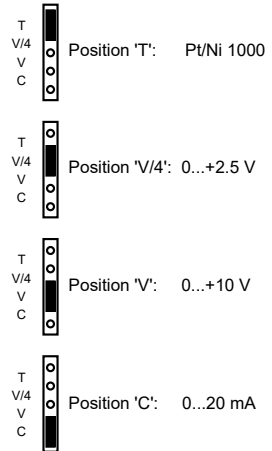
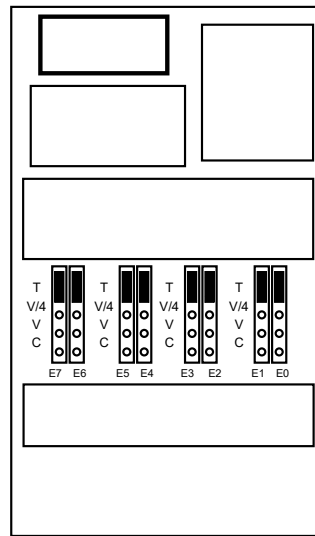

An dieses Modul dürfen keine negativen Eingangssignale angelegt werden.



Versetzen der Jumper

Auf dieser Leiterplatte befinden sich Bauteile, welche bezüglich elektrostatischen Entladungen empfindlich sind!



Jumper für die Auswahl der Betriebsart

Alle auf Temperatur (Position T) gestellten Eingänge müssen beschaltet sein. Nicht verwendete Eingänge sind auf den Strombereich 'C' oder den Spannungsbereich 'V' einzustellen.



Die Referenzpotentiale der Signalquellen sind auf einen gemeinsamen GND-Verteiler ("-" und "COM" Klemmen) zu verdrahten. Um optimale Messresultate zu erhalten, sollte jede Verbindung zu einer Erdungsschiene vermieden werden.



Werden abgeschirmte Kabel eingesetzt, sollte die Abschirmung unbedingt mit einer Erdungsschiene verbunden werden.



Eingangssignale mit falscher Polarität verfälschen signifikant die Messungen an den anderen Kanälen.



Die Eingänge sind von der CPU galvanisch getrennt, die Kanäle untereinander nicht.



E/A-Module und E/A Klemmenblöcke dürfen nur im spannungslosen Zustand der Saia PCD® gezogen oder gesteckt werden. Die externe Spannungsversorgung der Module +24 V muss auch ausgeschaltet werden.



Watchdog ..

.. in Classic Systemen

Der Watchdog mit seiner Adresse 255 kann dieses Modul beeinflussen, wenn es an der Basisadresse 240 eingesetzt wird.

.. im IEC-Controller

Ist davon nicht betroffen.



Weitere Informationen

Mehr Details, auch über den Watchdog, sind im Handbuch "27-600_EA-Module für PCD1 / PCD2 und PCD3" zu finden.

Anschlusskonzepte

Die Eingangssignale werden direkt an den 10-poligen Klemmenblock angeschlossen (E0...E7). Um möglichst wenig Störungen über die Leitungen auf das Modul einzukoppeln, soll der Anschluss nach dem anschliessend erläuterten Prinzip erfolgen.

Anschluss für 0 ... 10 V

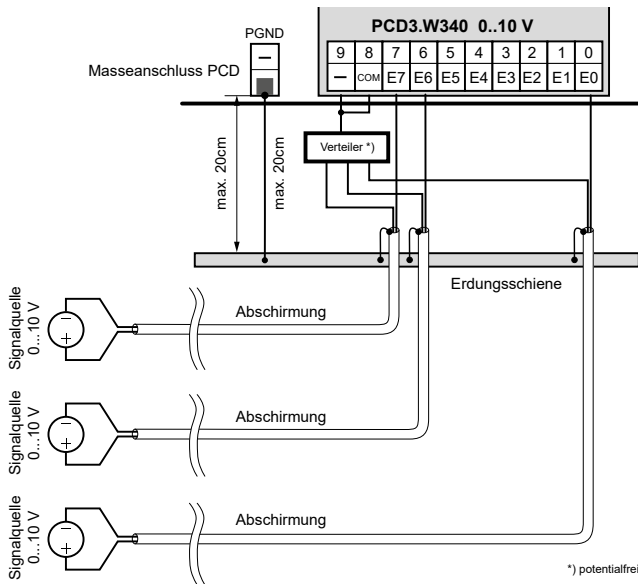

Anschluss für 0...20 mA mit Zweidraht-Messumformer

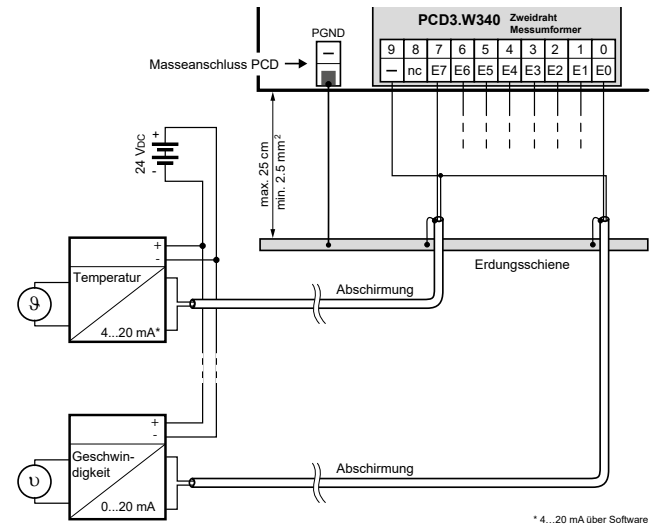

Zweidraht-Messumformer benötigen eine 24 VDC-Speisung in der Messleitung.

Gemischter Anschluss

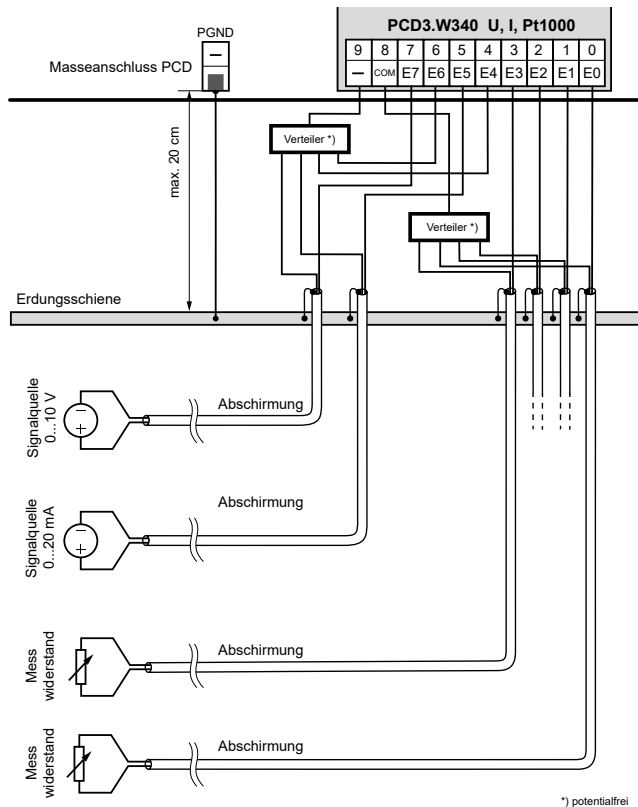

Formeln für Temperaturmessung

T = Temperatur in °C

DV = Digitaler Wert (0 ... 4095)

For Ni1000

Gültigkeit: Temperaturbereich - 50 ... + 210 °C

Rechenungenauigkeit: ± 0.5 °C

$$T = - 188.5 + \frac{260 \cdot DV}{2616} - 4.676 \cdot 10^{-6} \cdot (DV - 2784)^2$$

For Pt1000

Validity: Temperature range - 50 ... + 400 °C

Computational error: ± 1.5 °C

$$T = - 366.5 + \frac{450 \cdot DV}{2474} + 18.291 \cdot 10^{-6} \cdot (DV - 2821)^2$$

Widerstandsmessung bis 2.5 kΩ (PCD3.W340)

An die PCD3.W340 können spezielle Temperatur-Sensoren oder auch jegliche andere Widerstände bis 2.5 kΩ angeschlossen werden. Der digitale Messwert kann folgendermassen berechnet werden:

$$DV = \frac{16380 \cdot R}{(7500 + R)}$$

Konfigurierung

Saia PG5® Controls Suite

PCD-System	Auswertung																																																																																				
Classic	<p>Die Auswertung wird von der Firmware durchgeführt. Sie liest die Werte entsprechend der Konfiguration (Gerätekonfigurator oder Netzwerkkonfigurator) aus.</p> <div style="border: 1px solid #ccc; padding: 5px; margin-top: 10px;"> <p>Properties</p> <p>Slot 2 : PCD3.W340, 8 Analogue Inputs, 0...+10V, 0...20mA or Pt/Ni 1000</p> <table border="1" style="width: 100%; border-collapse: collapse;"> <tr><th colspan="2">General</th></tr> <tr><td>BaseAddress</td><td>32</td></tr> <tr><td>Connector Type</td><td>Type A, Spring Terminals 10-pole</td></tr> <tr><th colspan="2">Power Consumption</th></tr> <tr><td>Power Consumption 5V [mA]</td><td>8</td></tr> <tr><td>Power Consumption V+ [mA]</td><td>20</td></tr> <tr><th colspan="2">Media Mapping</th></tr> <tr><td>Media Mapping Enabled</td><td>No</td></tr> <tr><td>Media Type</td><td>Register</td></tr> <tr><td>Number Of Media</td><td>8</td></tr> <tr><th colspan="2">Analogue Input 0</th></tr> <tr><td>Input 0 Range</td><td>0...10V in mV resolution</td></tr> <tr><td>Minimum Value Input 0</td><td>0</td></tr> <tr><td>Maximum Value Input 0</td><td>10000</td></tr> <tr><th colspan="2">Analogue Input 1</th></tr> <tr><td>Input 1 Range</td><td>0..20mA in uA resolution</td></tr> <tr><td>Minimum Value Input 1</td><td>0</td></tr> <tr><td>Maximum Value Input 1</td><td>20000</td></tr> <tr><th colspan="2">Analogue Input 2</th></tr> <tr><td>Input 2 Range</td><td>Pt 1000 (-50...+400°C)</td></tr> <tr><td>Minimum Value Input 2</td><td>-500</td></tr> <tr><td>Maximum Value Input 2</td><td>4000</td></tr> <tr><th colspan="2">Analogue Input 3</th></tr> <tr><td>Input 3 Range</td><td>Ni 1000 (-50...+200°C)</td></tr> <tr><td>Minimum Value Input 3</td><td>-500</td></tr> <tr><td>Maximum Value Input 3</td><td>2000</td></tr> <tr><th colspan="2">Analogue Input 4</th></tr> <tr><td>Input 4 Range</td><td>Ni 1000 L&S (-60...+240°C)</td></tr> <tr><td>Minimum Value Input 4</td><td>-600</td></tr> <tr><td>Maximum Value Input 4</td><td>2400</td></tr> <tr><th colspan="2">Analogue Input 5</th></tr> <tr><td>Input 5 Range</td><td>12 Bit resolution</td></tr> <tr><td>Minimum Value Input 5</td><td>0</td></tr> <tr><td>Maximum Value Input 5</td><td>4095</td></tr> <tr><th colspan="2">Analogue Input 6</th></tr> <tr><td>Input 6 Range</td><td>User defined range</td></tr> <tr><td>Minimum Value Input 6</td><td>0</td></tr> <tr><td>Maximum Value Input 6</td><td>1000</td></tr> <tr><th colspan="2">Analogue Input 7</th></tr> <tr><td>Input 7 Range</td><td>User defined range</td></tr> <tr><td>Minimum Value Input 7</td><td>0</td></tr> <tr><td>Maximum Value Input 7</td><td>400</td></tr> </table> <p>Number Of Media Number of media (register) used to map the 8 analogue values.</p> </div>	General		BaseAddress	32	Connector Type	Type A, Spring Terminals 10-pole	Power Consumption		Power Consumption 5V [mA]	8	Power Consumption V+ [mA]	20	Media Mapping		Media Mapping Enabled	No	Media Type	Register	Number Of Media	8	Analogue Input 0		Input 0 Range	0...10V in mV resolution	Minimum Value Input 0	0	Maximum Value Input 0	10000	Analogue Input 1		Input 1 Range	0..20mA in uA resolution	Minimum Value Input 1	0	Maximum Value Input 1	20000	Analogue Input 2		Input 2 Range	Pt 1000 (-50...+400°C)	Minimum Value Input 2	-500	Maximum Value Input 2	4000	Analogue Input 3		Input 3 Range	Ni 1000 (-50...+200°C)	Minimum Value Input 3	-500	Maximum Value Input 3	2000	Analogue Input 4		Input 4 Range	Ni 1000 L&S (-60...+240°C)	Minimum Value Input 4	-600	Maximum Value Input 4	2400	Analogue Input 5		Input 5 Range	12 Bit resolution	Minimum Value Input 5	0	Maximum Value Input 5	4095	Analogue Input 6		Input 6 Range	User defined range	Minimum Value Input 6	0	Maximum Value Input 6	1000	Analogue Input 7		Input 7 Range	User defined range	Minimum Value Input 7	0	Maximum Value Input 7	400
General																																																																																					
BaseAddress	32																																																																																				
Connector Type	Type A, Spring Terminals 10-pole																																																																																				
Power Consumption																																																																																					
Power Consumption 5V [mA]	8																																																																																				
Power Consumption V+ [mA]	20																																																																																				
Media Mapping																																																																																					
Media Mapping Enabled	No																																																																																				
Media Type	Register																																																																																				
Number Of Media	8																																																																																				
Analogue Input 0																																																																																					
Input 0 Range	0...10V in mV resolution																																																																																				
Minimum Value Input 0	0																																																																																				
Maximum Value Input 0	10000																																																																																				
Analogue Input 1																																																																																					
Input 1 Range	0..20mA in uA resolution																																																																																				
Minimum Value Input 1	0																																																																																				
Maximum Value Input 1	20000																																																																																				
Analogue Input 2																																																																																					
Input 2 Range	Pt 1000 (-50...+400°C)																																																																																				
Minimum Value Input 2	-500																																																																																				
Maximum Value Input 2	4000																																																																																				
Analogue Input 3																																																																																					
Input 3 Range	Ni 1000 (-50...+200°C)																																																																																				
Minimum Value Input 3	-500																																																																																				
Maximum Value Input 3	2000																																																																																				
Analogue Input 4																																																																																					
Input 4 Range	Ni 1000 L&S (-60...+240°C)																																																																																				
Minimum Value Input 4	-600																																																																																				
Maximum Value Input 4	2400																																																																																				
Analogue Input 5																																																																																					
Input 5 Range	12 Bit resolution																																																																																				
Minimum Value Input 5	0																																																																																				
Maximum Value Input 5	4095																																																																																				
Analogue Input 6																																																																																					
Input 6 Range	User defined range																																																																																				
Minimum Value Input 6	0																																																																																				
Maximum Value Input 6	1000																																																																																				
Analogue Input 7																																																																																					
Input 7 Range	User defined range																																																																																				
Minimum Value Input 7	0																																																																																				
Maximum Value Input 7	400																																																																																				
Alternativ	<p>Zur Auswertung existiert eine "PCD2/3 W34" FBox.</p> <p>FBox für PCD3.W340 (Eingänge 0...7 wählbar)</p> <div style="display: flex; justify-content: space-around; margin-top: 10px;"> <div style="border: 1px solid #ccc; padding: 5px; text-align: center;"> <p>PCD2/3.W34</p> <p>in0</p><p>in1</p><p>in2</p><p>in3</p><p>in4</p><p>in5</p><p>in6</p><p>in7</p><p>Error</p> <p>Add 180</p> </div> <div style="border: 1px solid #ccc; padding: 5px; text-align: center;"> <p>PCD2/3.W34</p> <p>in0</p><p>Error</p> <p>Add 116</p> </div> </div>																																																																																				

Saia Qronox ECS Engineering and Commissioning Suite

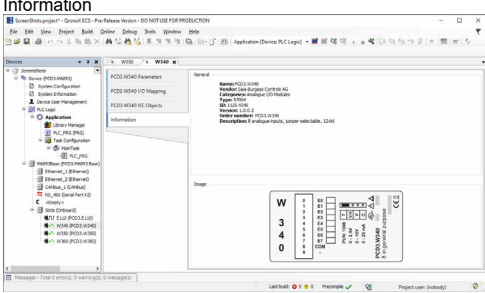
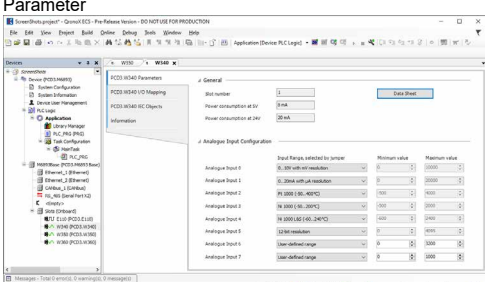
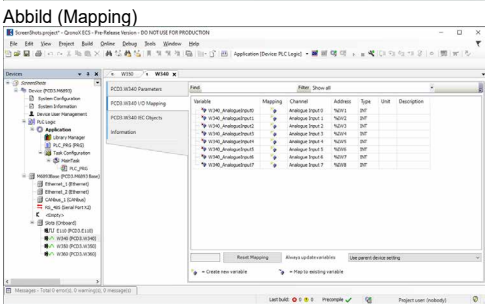
PCD-System	Auswertung																																																															
IEC-Controller	<p>Die Auswertung wird von der Firmware durchgeführt. Sie liest die Werte entsprechend der Konfiguration (Gerätekonfigurator).</p> <div style="margin-top: 10px;"> <p>Information</p>  <p>Parameter</p>  <p>Abbild (Mapping)</p>  <table border="1" style="width: 100%; border-collapse: collapse; margin-top: 10px;"> <thead> <tr> <th>Variable</th> <th>Mapping</th> <th>Channel</th> <th>Address</th> <th>Type</th> <th>Unit</th> <th>Description</th> </tr> </thead> <tbody> <tr><td>in0_AnalogInput0</td><td>0...10V with mV resolution</td><td>0</td><td>7001</td><td>20F</td><td></td><td></td></tr> <tr><td>in1_AnalogInput1</td><td>0..20mA with uA resolution</td><td>1</td><td>7002</td><td>20F</td><td></td><td></td></tr> <tr><td>in2_AnalogInput2</td><td>Pt 1000 (-50...+400°C)</td><td>2</td><td>7003</td><td>20F</td><td></td><td></td></tr> <tr><td>in3_AnalogInput3</td><td>Ni 1000 (-50...+200°C)</td><td>3</td><td>7004</td><td>20F</td><td></td><td></td></tr> <tr><td>in4_AnalogInput4</td><td>Ni 1000 L&S (-60...+240°C)</td><td>4</td><td>7005</td><td>20F</td><td></td><td></td></tr> <tr><td>in5_AnalogInput5</td><td>12Bit resolution</td><td>5</td><td>7006</td><td>20F</td><td></td><td></td></tr> <tr><td>in6_AnalogInput6</td><td>User defined range</td><td>6</td><td>7007</td><td>20F</td><td></td><td></td></tr> <tr><td>in7_AnalogInput7</td><td>User defined range</td><td>7</td><td>7008</td><td>20F</td><td></td><td></td></tr> </tbody> </table> </div>	Variable	Mapping	Channel	Address	Type	Unit	Description	in0_AnalogInput0	0...10V with mV resolution	0	7001	20F			in1_AnalogInput1	0..20mA with uA resolution	1	7002	20F			in2_AnalogInput2	Pt 1000 (-50...+400°C)	2	7003	20F			in3_AnalogInput3	Ni 1000 (-50...+200°C)	3	7004	20F			in4_AnalogInput4	Ni 1000 L&S (-60...+240°C)	4	7005	20F			in5_AnalogInput5	12Bit resolution	5	7006	20F			in6_AnalogInput6	User defined range	6	7007	20F			in7_AnalogInput7	User defined range	7	7008	20F		
Variable	Mapping	Channel	Address	Type	Unit	Description																																																										
in0_AnalogInput0	0...10V with mV resolution	0	7001	20F																																																												
in1_AnalogInput1	0..20mA with uA resolution	1	7002	20F																																																												
in2_AnalogInput2	Pt 1000 (-50...+400°C)	2	7003	20F																																																												
in3_AnalogInput3	Ni 1000 (-50...+200°C)	3	7004	20F																																																												
in4_AnalogInput4	Ni 1000 L&S (-60...+240°C)	4	7005	20F																																																												
in5_AnalogInput5	12Bit resolution	5	7006	20F																																																												
in6_AnalogInput6	User defined range	6	7007	20F																																																												
in7_AnalogInput7	User defined range	7	7008	20F																																																												

**GEFAHR**

Diese Geräte dürfen nur durch eine Elektrofachkraft installiert werden, andernfalls besteht Brandgefahr oder Gefahr eines elektrischen Schlages!

**WARNUNG**

Das Produkt ist nicht für den Einsatz in sicherheitskritischen Anwendungen vorgesehen. Die Verwendung in sicherheitskritischen Anwendungen ist unsicher.

**WARNUNG**

Das Gerät ist nicht geeignet für den explosionsgeschützten Bereich und den Einsatzbereichen, die in EN 61010 Teil 1 ausgeschlossen sind.

**WARNUNG - SICHERHEITSHINWEISE**

Nennspannung beachten, bevor das Gerät in Betrieb genommen wird (siehe Typenschild). Es ist darauf zu achten, dass die Anschlussleitungen nicht beschädigt und während der Verdrahtung des Gerätes spannungsfrei sind. Ein beschädigtes Gerät darf nicht verwendet werden !

**HINWEIS**

Um Feuchtigkeit im Gerät durch Kondenswasser zu vermeiden, das Gerät vor dem Anschliessen ca. eine halbe Stunde bei Raumtemperatur akklimatisieren.

**REINIGUNG**

Die Module können, im spannungsfreien Zustand, mit einem trockenen oder mit Seifenlösung angefeuchtetem Tuch gesäubert werden. Auf keinen Fall dürfen ätzende oder lösungsmittelhaltige Substanzen zur Reinigung verwendet werden.

**WARTUNG**

Diese Geräte sind wartungsfrei.
Bei Beschädigungen der Geräte dürfen vom Anwender keine Reparaturen vorgenommen werden.



Bitte diese Anweisungen (Datenblatt) beachten und an einem sicheren Ort aufbewahren.
Diese Anweisungen (Datenblatt) bitte an jeden zukünftigen Benutzer weitergeben.



WEEE Directive 2012/19/EC Waste Electrical and Electronic Equipment directive
Am Ende der Produktlebensdauer ist die Verpackung und das Produkt in einem entsprechenden Recyclingzentrum zu entsorgen! Das Gerät nicht mit dem üblichen Hausmüll entsorgen ! Das Produkt darf nicht verbrannt werden!



EAC Konformitätszeichen für Maschinen-Exporte nach Russland, Kasachstan und Belarus.



PCD3.W340



4 405 4954 0

Bestellangaben

Typ	Kurzbeschreibung	Beschreibung	Gewicht
PCD3.W340	8 analoge Eingänge, 12 Bit, 0...2.5 V, 0...10 V, 0...20 mA oder Pt/Ni1000	Analoges Eingangsmodul, 8 Kanäle, Auflösung 12 Bit, Bereiche pro Kanal wählbar 0...2.5 V, 0...10 V, 0...20 mA, Pt/Ni1000. Die Kanäle sind untereinander nicht getrennt. Anschluss mit steckbaren Federklemmen, Steckertyp A (4 405 4954 0) mitgeliefert	80 g

Bestellangaben Zubehör

Typ	Kurzbeschreibung	Beschreibung	Gewicht
4 405 4954 0	Stecker Typ A	Steckbarer E/A-Federkraftklemmenblock, 10 polig bis 2.5 mm ² , Beschriftung 0 ... 9.	15 g

Saia-Burgess Controls AG
 Bahnhofstrasse 18 | 3280 Murten, Schweiz
 T +41 26 580 30 00 | F +41 26 580 34 99
 www.saia-pcd.com
 support@saia-pcd.com | www.sbc-support.com

Honeywell | Partner Channel