

# PCD3.M6880

## High Power Standby Controller

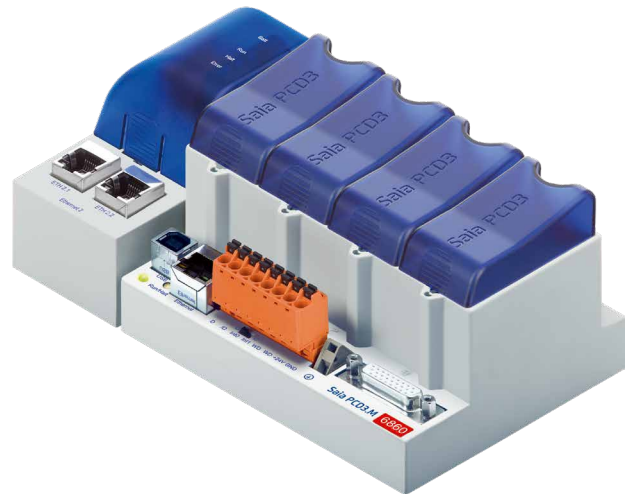

The PCD3.M6880 Standby Controllers are for creating redundant automation solutions, to ensure the uninterrupted operation of systems and processes.

**Standby (redundant automation) systems from SBC have the following characteristics:**

- ▶ Based on the modular and robust PCD3 family, using standard modules.
- ▶ Simple system architecture to reduce costs.
- ▶ Standby processors with shared Ethernet Remote I/Os avoids the duplication of the inputs/outputs and the sensors/actuators.
- ▶ Programmable remote I/Os create intelligent decentralized nodes to provide additional reliability.
- ▶ The network uses standard Ethernet components, and can run over a standard Ethernet TCP/IP network along with other services.
- ▶ Easy engineering and commissioning, using the PG5 Project Manager to automatically generate the project.
- ▶ Uninterrupted switching from Standby to Active device.
- ▶ Standby controllers contain two processors. One processor runs the redundant program and monitors the active PCD. The second independent processor runs other non-redundant processes. This significantly increases the performance and flexibility of the system.
- ▶ Comprehensive diagnostic features to aid commissioning and fault finding.

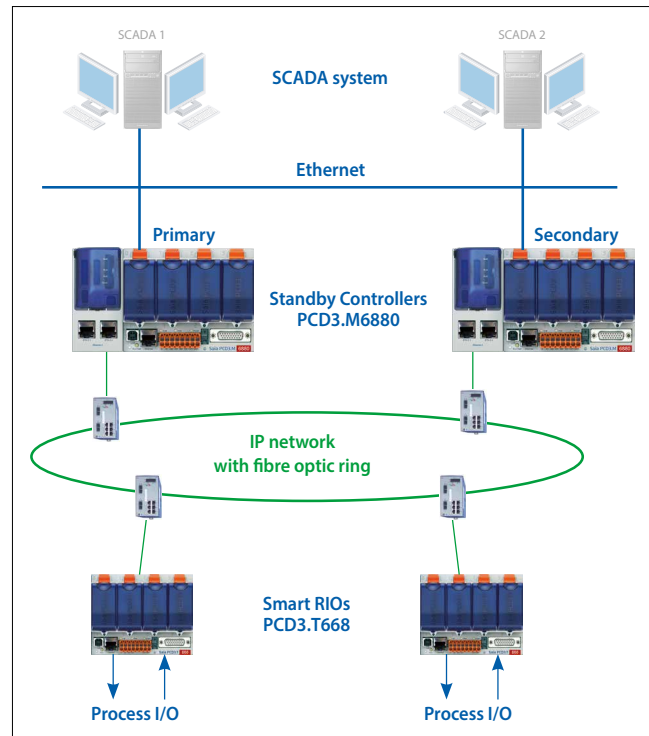

Typical layout of a redundancy system with two PCD3.M6880 Standby devices and PCD3.T668 Ethernet Smart RIOs.

# Terminology

The following definitions will provide a better understanding of the properties and operating principles:

- Standby Controller** The PCD3.M6880 controller which supports the standby feature.
- Primary PCD** The PCD which becomes the active device by default when the system is powered up, depending on the configuration.
- Secondary PCD** The PCD which becomes the standby device on power up, and only takes over active control in the event of a fault on the active device.
- Active PCD** The PCD whose CPU1 is in Active Mode, running the redundant program and controlling the inputs/outputs (PCD3.T668 RIOs).
- Standby PCD** The PCD whose CPU1 is in Standby mode. It does not run the redundant program and the outputs (PCD3.T668 RIOs) are not controlled by this device.
- Main CPU** CPU0 of the Primary or the Secondary PCD, which runs the non-redundant program. This program may be different on the Primary and Secondary devices.
- Redundant CPU** CPU1 of the Primary or Secondary PCD, which contains the Redundant program. This program must be the same on the primary and Secondary devices. This CPU is either in Active mode and running the Redundant program, or in Standby mode and monitoring the Active PCD.

Redundant control solutions are created using two PCD3.M6880 Standby Controllers. The input/outputs (process signals) are connected and controlled via PCD3.T668 Ethernet smart RIOs. The RIO stations are connected to both controllers via an Ethernet connection. This means there is no need to have duplicate inputs, outputs, sensors and actuators. The two PCDs (primary and secondary) monitor each other. If the active PCD fails, the standby PCD takes over processing and control of the connected RIO stations. The process image (I/O) and the internal PCD media (F, R, T, C, DB) - the synchronization data - are continuously transferred from the active PCD to the standby PCD via the Ethernet connection. This ensures uninterrupted switching from the active to the standby PCD.

The Redundant CPU1 has two independent Ethernet interfaces. The ETH 2.x interface is reserved exclusively for operating the PCD3.T668 RIO stations. The PCDs also synchronize their process data via the same interface. For security reasons, we recommend setting up this network as a ring structure with specific network components from third-party providers. We have had good experiences with the industrial Ethernet switches from Hirschmann.

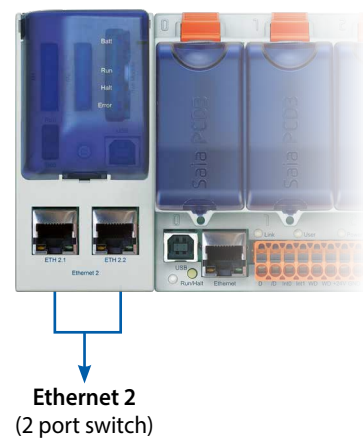

The ETH 1 interface on CPU0 is available for connecting and operating other systems and devices. For example, SCADA systems can be connected via this interface. SBC does not provide its own SCADA system for redundant automation solutions, but almost any system can be used. A single SCADA system, or an additional redundant SCADA system can be used if it supports redundant controllers. The PCD3.M6880 controllers provide detailed status and diagnostic information which can be evaluated by the SCADA systems.

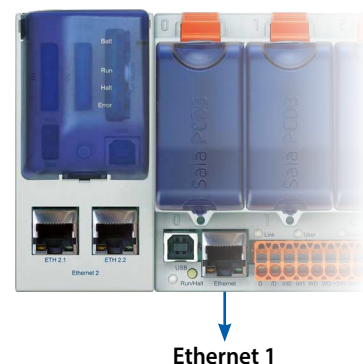

# Designing the System

Redundant automation solutions can be achieved with various network topologies.

Physically separating the management network (SCADA systems) and the network for the remote I/Os is recommended. We also recommend setting up the remote I/O network in a ring structure using fibre-optic network components. This significantly increases the performance, security and, above all, the network availability and thus the system reliability. Standard devices from third-party providers can be used for the network components (switches). We have had good experiences with the switches (RS30) from Hirschmann. However, the networks can also be set up with standard components in a star structure. A shared physical network for the remote I/Os and management systems is also possible, but availability of the system will be reduced accordingly.

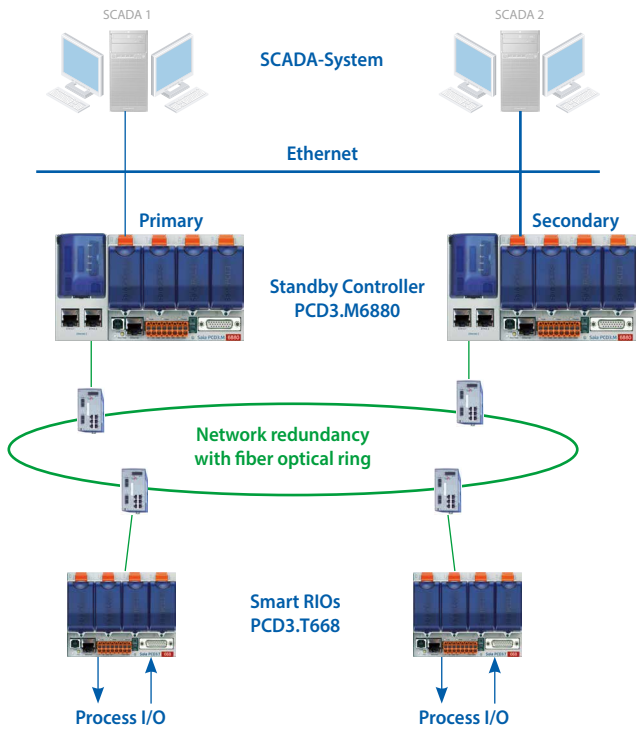

Recommended network topology with physically separate networks and a fibre-optic ring

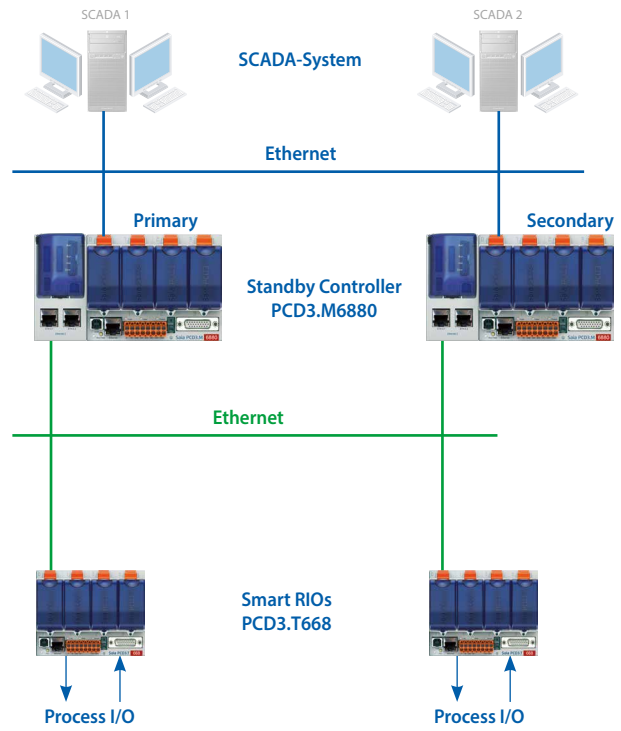

Physically separate networks in a star topology with standard components

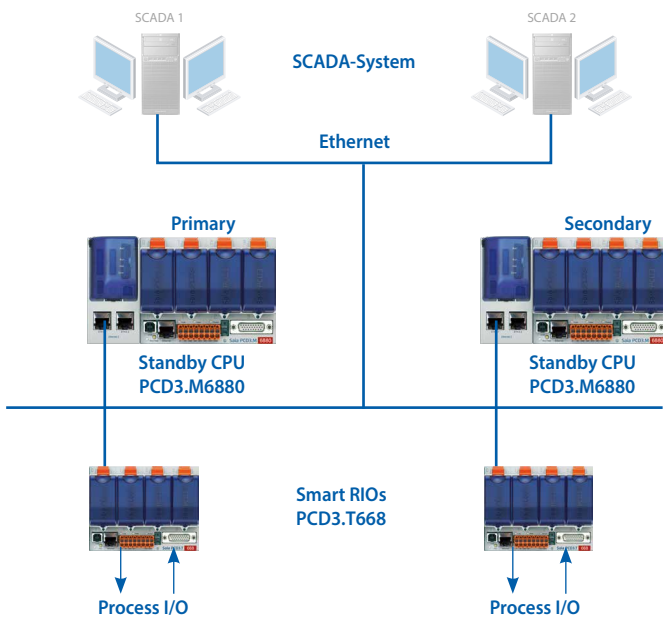

Shared physical network in a star topology with standard components

# PCD3.M6880 Standby Controller

## Architecture of the PCD3.M6880

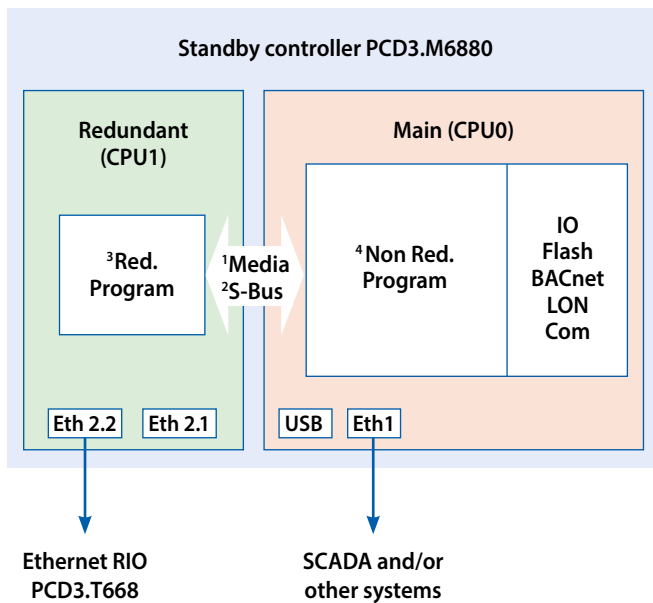

PCD3.M6880



- <sup>1</sup> Data Media Transfer (Exchange Range or/and CSF/FBox)
- <sup>2</sup> S-Bus GWY CPU0 to CPU1 (2 different S-Bus address)
- <sup>3</sup> Redundant program on CPU1 runs only if active. Same program on both PCDs.
- <sup>4</sup> Non-redundant program can be different in both PCDs.

The PCD3.M6880 standby controller has two independent processors (CPU0 and CPU1). Both processors have their own independent PCD media (F, R, T, C, DB/TX).

The redundant CPU1 runs the redundant user program and controls the shared inputs/outputs of the PCD3.T668 remote I/Os. The redundant programs in the primary and secondary PCD3.M6880s are identical. During normal operation, only the active PCD runs the redundant program. CPU1's internal used PCD media (F, R, T, C, DB/TX) are transferred from the active to the standby PCD via the Ethernet interface 2 (ETH2.x). In the event of a fault, the standby PCD takes over operation without interruption, and runs the redundant program using the last process image from the active PCD.

Depending on requirements, the user programs of the main CPU0 can be different in the primary and secondary PCD3.M6880. CPU0 has the same capabilities as a standard PCD (e.g. PCD3.M5560). Local I/Os in the PCD's slots, and the I/O expansion modules, are controlled by CPU0. External systems and devices (SCADA systems, web browsers and other external devices) communicate only with CPU0. CPU0's internal PCD media (F, R, T, C, DB) are not synchronized between the active and standby PCD.

CPU1's program cannot directly access the local I/Os or CPU0's media (and vice versa). Data is exchanged between CPU0 and CPU1 using a data exchange mechanism. The data to be exchanged (PCD media) are define in global symbol files. This data is automatically exchanged between CPU0 and CPU1 on each program cycle.

# Saia PCD3.M6880 controllers

## High Power Standby Controller

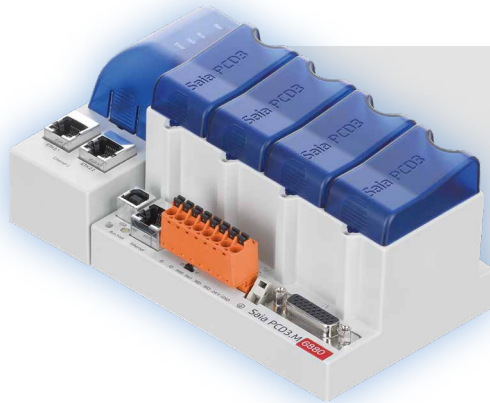

1.023	I/O
up to 4.2 GB	File system
2 MB	Program
0.1/0.3 μs bit/word	CPU speed

Property/function	PCD3.M6880	
	Main CPU0	Redundant CPU1
Number of inputs/outputs	1023	—
or I/O-module slots	64	—
I/O expansion connection for PCD3.C module holder	Yes	—
Processing time [μs]	0.1...0.8 μs	
bit operation	0.3 μs	
word operation		
Real time clock (RTC)	Yes	

### On-Board memory

Program memory, DB/TEXT (Flash)	2 MByte	
User memory, DB/TEXT (RAM)	1 MByte	128 KByte
Flash memory (Program, S-RIO and configuration)	128 MByte	
User flash file system (INTFLASH)	128 MByte	—
PCD media:		
Register	16384	16384
Flag	16384	16384
DB/TEXT	8192	8192

### On-Board interfaces

USB 1.1	Yes	No
Ethernet 10/100 Mbit/s, full-duplex, auto-sensing/auto-crossing	ETH1	ETH2.x (2 port switch)
RS-485 on terminal block (Port 2) or RS-485 Profibus-DP Slave, Profi-S-Net on terminal block (Port 2)	up to 115 kbit/s up to 187.5 kbit/s	—

### Optional communication interfaces

I/O slot 0: PCD3.F1xx modules for RS-232, RS-422, RS-485 and Belimo MP-Bus	Yes	No
I/O slot 0...3 up to 4 modules or 8 interfaces: PCD3.F2xx modules for RS-232, RS-422, RS-485, BACnet® MS/TP, Belimo MP-Bus, DALI and M-Bus	Yes	No

### Other features

Communication protocols/systems (BACnet, Modbus, LonWORKS®, DALI, M-Bus...)	As PCD3.M6860 without 2nd Ethernet	No
Automation server (web server, FTP server, e-mail, SNMP, flash file system...)	Yes	No
Connection and operation of PCD3.T668 remote I/O	No	Yes
Number of supported RIO stations	—	64
Connection and operation of PCD3.T665/T666 remote I/O	Yes	No
Number of supported RIO stations	64	—
Access to the I/O slots in the basic housing as well as to the PCD3.Cxxx I/O terminal bases	Yes	No

## Switchover Criteria

Each of the Standby PCDs (CPU1) sends a „Keep Alive“ telegram to its partner for supervision.

### The STANDBY PCD switches to ACTIVE when:

- ▶ No Keep Alive telegram has been received within the „Keep alive timeout“ period defined with the Redundant CPU's Device Configurator. The „Keep Alive Timeout“ can be adjusted between 100...500 ms. By this the max. switchover latency is <100...500 ms.
- ▶ The ACTIVE PCD's state is not RUN or STOP (stops sending Keep Alive).
- ▶ A manual Switchover command is executed. This is only possible if the Primary device does not have priority, the „Primary device has priority“ option must be „No“.

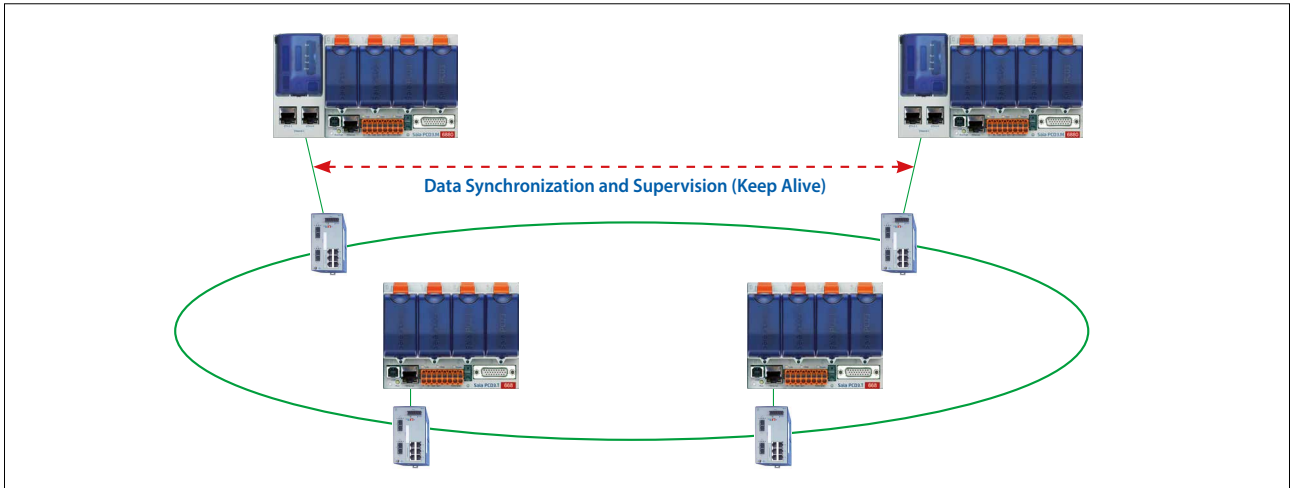

### Data Synchronisation and Program Cycle:

The used PCD medias (R, F, T/C, DB/TX) in the redundant CPU1 are cyclically synchronized between the active and the standby PCD. The synchronization time for all PCD media is normally less than 200 ms. This time is reduced accordingly if only a part of the PCD media is used. The total program cycle time is calculated as follows:

Total cycle time = program execution time + data synchronization time

The max. value for a large application can be calculated as follows: 100 ms + 200 ms = 300 ms max.  
For smaller applications where less PCD media are used the cycle time is reduced correspondingly.

## PCD3.T668 Standby RIO

### Architecture of the PCD3.T668

The PCD3.T668 remote I/Os are exclusively for use with the PCD3.M6880 Standby Controllers. With the exception of the redundancy function, they support the same properties/functions as the PCD3.T666 remote I/O station. The PCD.T665 and PCD3.T666 standard remote I/Os cannot be used with Standby Controllers.

- ▶ Can be used as a simple local I/O station or an intelligent programmable I/O station
- ▶ Can be programmed with the PG5. Important or timecritical tasks can be processed directly in the RIO
- ▶ The RIO's user programs are managed centrally by the Smart RIO Manager (PCD) and downloaded to the RIOs automatically
- ▶ Data exchange uses the efficient Ether-S-IO protocol. Simple configuration with the RIO Network Configurator
- ▶ Cross-communication with other PCD systems using Ether-S-Bus (FBoxes)
- ▶ Intelligent communication modules (e.g. M-Bus, DALI) are supported
- ▶ Other communication protocols (e.g. Modbus) via Ethernet TCP/IP and also by the onboard RS-485 interface
- ▶ Integrated Web Server





## Technical data

Property	PCD3.T668	
Number of inputs/outputs	64 in base unit, extensible to 256	
I/O-module slots	4 in base unit, extensible to 16	
I/O-modules supported	PCD3.Exxx, PCD3.Axxx, PCD3.Bxxx, PCD3.Wxxx	
Max. number of RIO stations	128	
Protocol for data transfer	Ether-S-IO	
Ethernet connection	10/100 Mbit/s, full-duplex, auto-sensing, auto-crossing	
Default IP configuration	IP address: 192.168.10.100 Subnet mask: 255.255.255.0 Default gateway: 0.0.0.0	
USB port for configuration and diagnostics	yes	
Program memory	128 kByte	
Web server for configuration and diagnostics	yes	
Web server for user pages	yes	
On-Board file system for web pages and data	512 kByte	
BACnet® or LonWORKS®	no	
On-Board interrupt inputs	2	
On-Board RS-485 interface	yes	
Special modules	for I/O-slot 0 only	PCD3.F1xx
	for I/O-slots 0...3 (up to 4 modules)	PCD3.H1xx counter PCD3.F26x DALI PCD3.F27x M-Bus
S-Web alarming/trending	no	
Watchdog	no	
Real-time clock	no	
Software clock (not battery-powered)	yes, synchronized by the Manager	
Battery	no	

## General data

Supply voltage	24 VDC ±20% smoothed or 19 VAC ±15% full-wave rectified
Capacity of 5 V bus / 24 V bus	max. 650 mA/100 mA
Ambient temperature	0...+55 °C or 0...+40 °C (depending on mounting position)
Storage temperature	-20...+70 °C
Relative humidity	30...95% RH with no condensation
Mechanical strength	according to EN/IEC 61131-2

## System properties/limits and recommendations for lean automation

With lean automation, it is not recommended to make full use of the specified limits with regard to the maximum number of stations per Manager and the maximum number of I/Os per RIO. The following points should be taken into account:



- ▶ The load on the RIO Manager increases with the rising number of RIO stations. This has an impact on the overall application in the RIO Manager.
- ▶ If there is a large number of RIOs, a sufficiently large amount of PCD media must be reserved on the Manager for the data transfer.
- ▶ With a rising number of RIO stations, the build and download process in PG5 is lengthened accordingly. Likewise, the start-up behavior of the Manager or the entire RIO network is proportionately longer.

**Recommendations:** 20 Smart RIOs per Manager is a sensible configuration for efficient and problem-free operation, and simple commissioning and support.

The Smart RIOs do not have a battery. In the event of an interruption to the power supply, all the data in the RAM memory (registers, flags, DBs/text) will be lost. Data and parameters that are to remain must either be transferred by the Manager or stored in the RIO's flash file system. If this is not possible, the use of a normal controller in place of a Smart RIO is recommended. The user programs are stored in the flash memory of the RIOs and are retained in the event of an interruption to the power supply.

## Connections

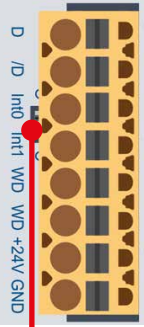
	Pin	Signal	Explanation
	1	D	<b>Port #2</b> RS-485 up to 115.2 kbit/s usable as free user interface or Profi-S-Bus up to 187.5 kbits/s
	2	/D	
	3	Int0	2 interrupt inputs 24 VDC or 1 rapid counter 24 VDC
	4	Int1	
	5	WD	Watchdog
	6	WD	
	7	+24V	Voltage supply
	8	GND	

### RS-485 terminator switch

Switch position	Designation	Explanation
left	O	without termination resistors
right	C	with termination resistors

## Dimension Drawing

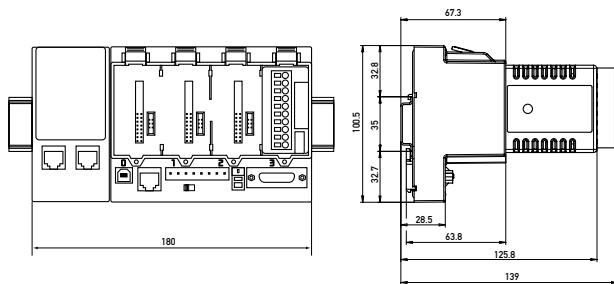

Further information can be found in the manual 27-645\_ENG "Standby Controller" and the manual 26-789\_ENG "Series PCD3".



I/O modules and I/O terminal blocks may only be plugged in and removed when the Saia PCD® and the external +24 V are disconnected from the power supply.



EAC Mark of Conformity for Machinery Exports to Russia, Kazakhstan or Belarus.

## Ordering information

Type	Short description	Description	Weight
PCD3.M6880	Modular PCD3 standby controller with 2 Ethernet TCP/IP ports and co-processor for standby operation	PCD3 Standby processor unit with 2 Ethernet TCP/IP and Co-processor for Standby operation, web and FTP server, file system, CPU with 2 MByte user program, 1 MByte SRam extension memory, 128 MByte user Flash memory with file system, clock (RTC), data protection 1-3 years, USB port for PG5, up to 1024 I/O, 2 interrupt inputs, RS-485 for Profi-S-Net/MPI/S-Bus	820 g

## Accessories

Type	Short description	Description	Weight
PCD3.T668	Modular PCD3 smart RIO for connection to the standby controller	Smart-RIO for Standby processor unit, Ether-S-IO data exchange, programmable, 128 KByte program memory, up to 256 I/O, 2 Interrupts, web server and on-board RS-485 interface	480 g
4 405 4995 0	8-pin spring terminal block	for power supply to PCD3.Mxxx0	34 g

### Saia-Burgess Controls AG

Bahnhofstrasse 18 | 3280 Murten, Switzerland  
 T +41 26 580 30 00 | F +41 26 580 34 99  
[www.saia-pcd.com](http://www.saia-pcd.com)

[support@saia-pcd.com](mailto:support@saia-pcd.com) | [www.sbc-support.com](http://www.sbc-support.com)