

Overview PCS1.C8xx

Übersicht PCS1.C8xx

Récapitulatif PCS1.C8xx

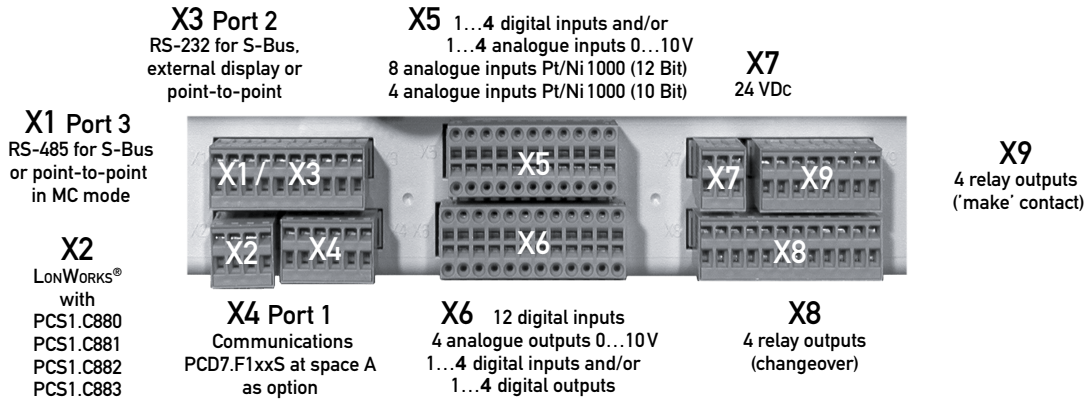

Block	Pin	Name	I/O address	Notes
X1	1	Data_Sbus		Port#3, RS-485 S-Bus Standard Port on all PCS1
	2	/Data_Sbus		
	3	GND		
X3	4	+5V		Port#2, RS-232 External display. Standard port on all PCS1.C822 and PCS1.C823
	5	n.c.		
	6	GND		
	7	CTS2_ext		
	8	RxD2_ext		
	9	RTS2_ext		
X2	1			LonWorks®
	2	LON A Data		
	3	LON B Data		
	4	GND		
X4	1	GND		Port#1 Optional port RS-485/RS-422/RS-232
	2	I1A		
	3	I1B		
	4	I1C		
	5	I1D		
	6	I1G		
X5	1	COM		GND for Pt/Ni 1000 ¹⁾ Inputs 0...10V or digital Inputs 24 VDC Base address = 48 see also FBox PCS1.W2xx Pt/Ni 1000
	3	E48	I 48 ch 0	
	5	E49	I 48 ch 1	
	7	E50	I 48 ch 2	
	9	E51	I 48 ch 3	
	11	GND		
	13	GND		
	15	E52	I 48 ch 4	
	17	E53	I 48 ch 5	
	19	E54	I 48 ch 6	
X5	2	COM		GND for Pt/Ni 1000 ¹⁾ Pt/Ni 1000 Base address = 64 see also FBox PCS1.W3xx
	4	E64	I 64 ch 0	
	6	E65	I 64 ch 1	
	8	E66	I 64 ch 2	
	10	E67	I 64 ch 3	
	12	GND		
	14	GND		
	16	E68	I 64 ch 4	
	18	E69	I 64 ch 5	
	20	E70	I 64 ch 6	
X6	1	E0	I 0	Digital inputs, 8 ms as PCD2.E110 Digital inputs, 0.2 ms as PCD2.E111
	3	E1	I 1	
	5	E2	I 2	
	7	E3	I 3	
	9	E4	I 4	
	11	E5	I 5	
	13	E6	I 6	
	15	E7	I 7	
	17	E8	I 8	
	19	E9	I 9	
X5	21	E10	I 10	Digital inputs, 0.2 ms as PCD2.E111
	23	E11	I 11	
	24	GND		

Block	Pin	Name	I/O address	Notes		
X6	2	GND		Outputs 0...10 V ¹⁾ Base address = 80 see also FBox PCS1.W4xx		
	4	A80	O 80 ch 0			
	6	A81	O 80 ch 1			
	8	A82	O 80 ch 2			
	10	A83	O 80 ch 3			
X7	12	GND		Selectable as digital inputs (as PCD2.B100) (I 12...I 15) or as digital outputs (O 12...O 15)		
	14	+24V_EXT				
	16	E/A12	I/O 12			
	18	E/A13	I/O 13			
	20	E/A14	I/O 14			
	22	E/A15	I/O 15			
	(24)	GND				
	X7	1	Uin +24 VDC			Power supply (inc. 24 VDC) for relays
		2	GND			
		3	GND			
3		NO20	O 20			
X8	2	COM20		1. Relay ²⁾ /open common closed		
	3	NC20	O 20			
	4	NO21	O 21			
	5	COM21				
	6	NC21	O 21			
	7	NO22	O 22			
	8	COM22				
	9	NC22	O 22			
	10	NO23	O 23			
	11	COM23				
	12	NC23	O 23			
	X9	1	COM16			5. Relay ²⁾ /common open
2		NO16	O 16			
3		COM17				
4		NO17	O 17			
5		COM18				
6		NO18	O 18			
7		COM19				
8		NO19	O 19			

Intern	A_M16	I 24	Switch pos.1
Intern	A_M17	I 25	
Intern	A_M18	I 26	
Intern	A_M19	I 27	
Intern	A_M20	I 28	Acknowledgement of manual/ emergency control level (Auto/Man = 1/0) ³⁾ Switch pos.1
Intern	A_M21	I 29	
Intern	A_M22	I 30	
Intern	A_M23	I 31	
Intern	A_M80_0	I 32	
Intern	A_M80_1	I 33	
Intern	A_M80_2	I 34	
Intern	A_M80_3	I 35	

¹⁾ extra filtered

²⁾ With manual/emergency control level as option

³⁾ Caution: If the manual/emergency control level is not equipped, the status of inputs I24 to I35 is always logical "1".

Communication Interfaces PCS1.C8xx

Kommunikations-Schnittstellen PCS1.C8xx

Interfaces de communication PCS1.C8xx

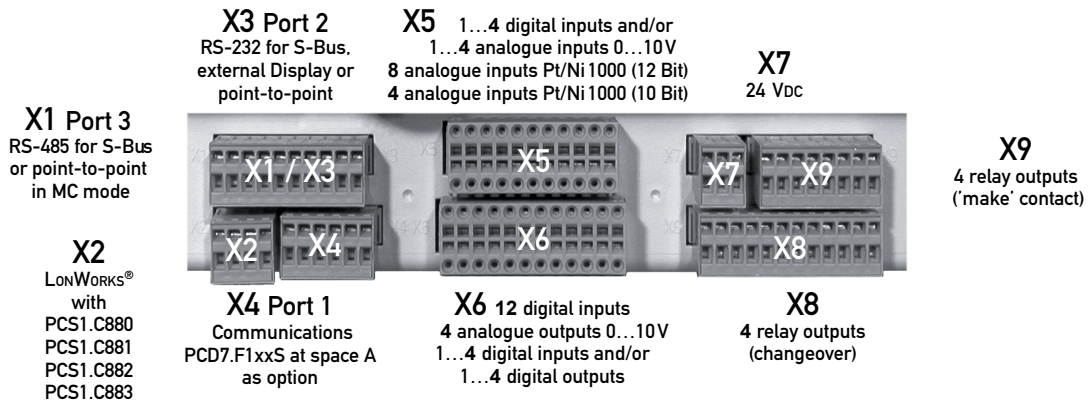

Pins on terminal block X4 for PCD7.F1x0 communications modules at space A

Pin	PCD7.F110S RS-485	PCD7.F110S RS-422	PCD7.F121S RS-232	PCD7.F150S RS-485 *g.i.	PCD7.F180S MP-Bus	*g.i. = galvanically isolated
1 (gnd)	GND	GND	GND	—	GND	MP-Bus GND
2 (I1A)	RX - TX	TX	TX	RX - TX	A-COM	MP-Bus signal line
3 (I1B)	/RX - /TX	/TX	RX	/RX - /TX	MST	BELIMO® programming unit
4 (I1C)	—	RX	RTS	—	IN	BELIMO® programming unit detection
5 (I1D)	—	/RX	CTS	—	GND	BELIMO® programming unit GND
6 (I1G)	—	—	—	SGND	—	—

S-Bus/RS-485

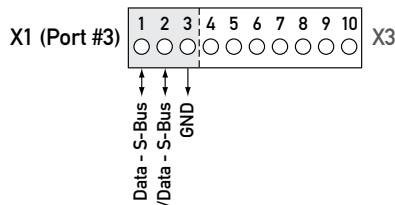

PCD7.F110S – S-Bus/RS-485

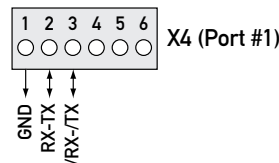

LonWorks® – PCS1.C880...C883

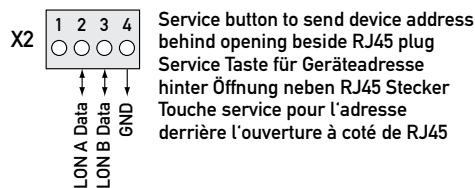

PCD7.F121S – RS-232

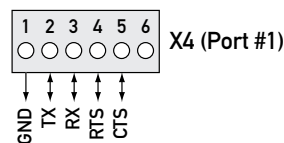

Display PCD7.D230/RS-232 (C822 & C823)

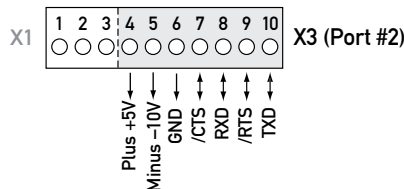

PCD7.F180S – BELIMO® MP-Bus

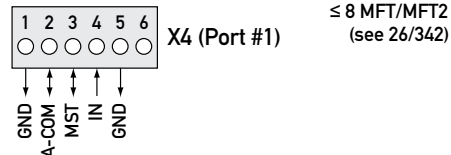

PCD7.F110S – RS-422

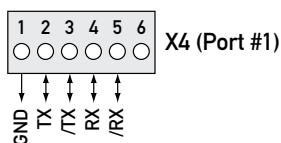

PCD7.F121S – EIB/RS-232

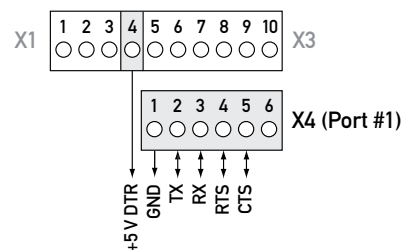

I/O Interfaces PCS1.C8xx

E/A-Schnittstellen PCS1.C8xx

Interfaces d'E/S PCS1.C8xx

X5

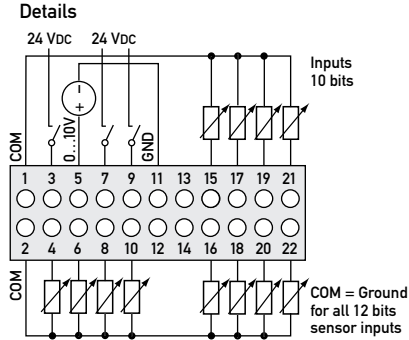
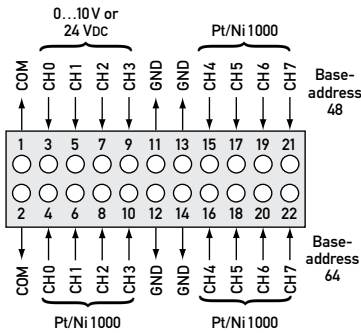

X6

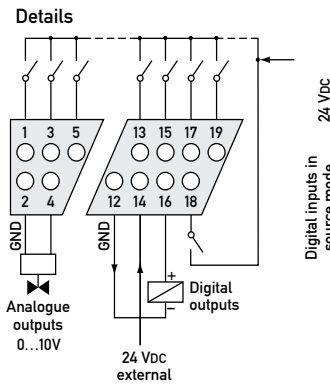
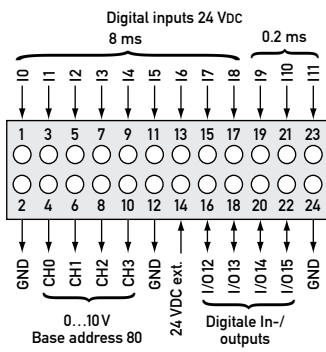

IMPORTANT If combined I/Os 12...15 are used as outputs, an external supply is required (24 VDC external). In such cases only source operation will be possible at the inputs.
WICHTIG Werden kombinierte E/A 12...15 als Ausgänge verwendet, ist eine externe Speisung erforderlich (24 VDC extern). In diesem Fall ist bei den Eingängen nur Quellbetrieb möglich.
IMPORTANT Des qu'une des 4 I/O mixt 12...15 est utilisée comme sortie, une alimentation externe de 24 VCC est nécessaire à la borne 14. Dans ce cas, seul le fonctionnement en logique positive est possible pour les autres entrées.

X7

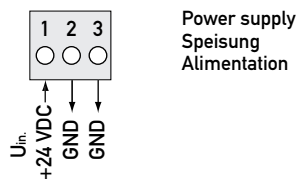

X8

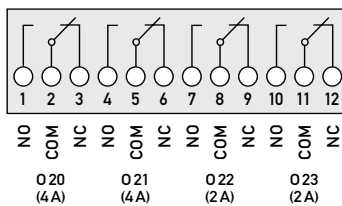

Details

2-stage fan controller with mutual latching
 2-stufige Ventilatorsteuerung mit gegenseitiger Verriegelung
 Commande de ventilateur bivitesse avec verrouillage des sorties entre elles.

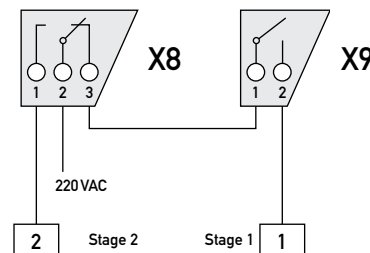

X9

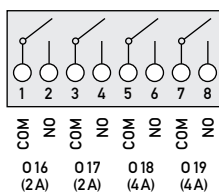

PCS1.C8xx

Mounting instruction Montageanleitung Assemblage

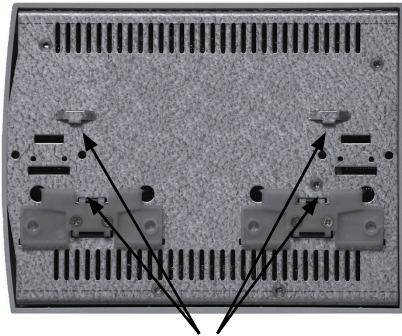

Standard mounting on 35 mm top-hat rail DIN EN 60715
Standard-Montage auf 35 mm-Hutschiene DIN EN 60715
Montage classique sur rail 35 mm DIN EN 60715

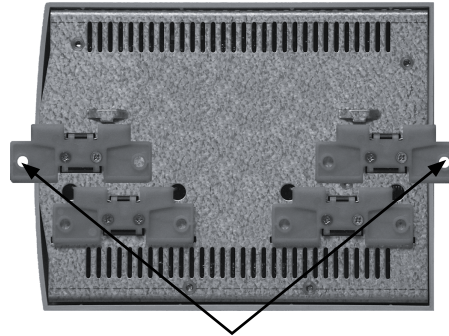

Wall-mounting as option
Wandmontage als Option
Montage mural en option
(4'109'4849'0)

Plug-in spring terminals Steckbare Federkraftklemmen Bornier à ressort embrochable

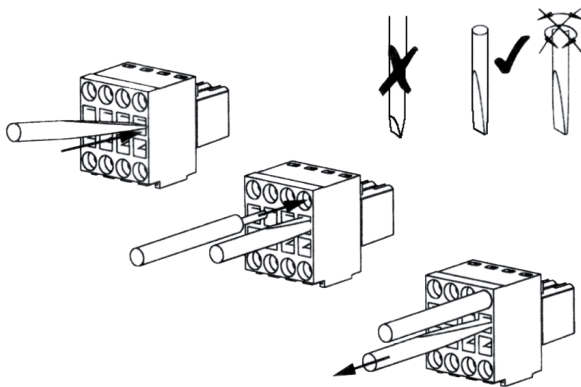

The process input terminals are up to 1.0 mm² and the process output terminals are up to 1.5 mm². Process cable must be bared along 7...8 mm (1.0 mm²) or 10 mm (1.5 mm²) and inserted in the terminals.

UL Compliance:

For use of 60/75 °C copper (Cu) wire only.

IMPORTANT: Screwdrivers used should be type SDI 0.4 × 2.5 × 80 (max. width 2.5 mm).

Die Prozess-Eingangsklemmen sind bis 1.0 mm² und die Prozess-Ausgangsklemmen bis 1.5 mm² ausgelegt. Die Prozesskabel müssen 7...8 mm (1.0 mm²) bzw. 10 mm (1.5 mm²) abisoliert und in die Klemmen gesteckt werden.

UL-konformer Einsatz:

Nur 60/75 °C Kupferleiter (Cu) verwenden.

WICHTIG: Schraubendreher des Typs SDI 0.4 × 2.5 × 80 verwenden (max. Breite von 2.5 mm).

Leur section maximale est de 1 mm² pour les entrées et de 1.5 mm² pour les sorties. Le câble de raccordement côté PCS doit être dénudé sur 7 à 8 mm (1 mm²) ou 10 mm (1.5 mm²), puis être inséré dans les bornes.

Conformité UL :

N'utiliser que des fils de cuivre (Cu) 60/75 °C.

IMPORTANT: utiliser un tournevis du type SDI 0.4 × 2.5 × 80 (largeur max. 2.5 mm) pour ouvrir les ressorts.

Dimension drawing Massbild Schémas cotés

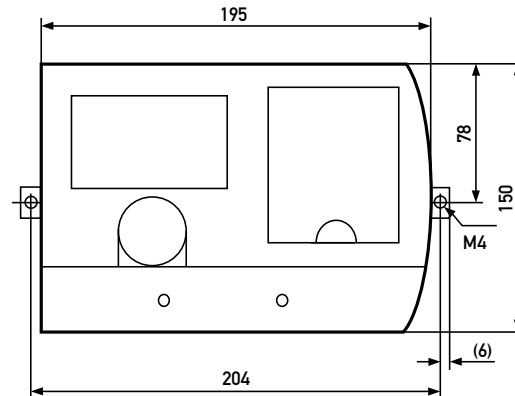

Device depth: 60 mm
Gerätetiefe: 60 mm
Profondeur: 60 mm

Terminal cover Klemmenabdeckung Capot cache-bornes

4'111'4927'0



Mounting with the enclosed screws.
Befestigung mit den beiliegenden Schrauben.
Montage avec les visses fournies.

UL Compliance:

Ambient temperature operation max. 55 °C

UL-konformer Einsatz:

Umgebungstemperatur Betrieb max. 55 °C

Conformité UL :

Température ambiante de service 55 °C maxi

For more details, see Technical Information P+P26/345.

Weitere Informationen, siehe TI P+P26/345.

Pour tous détails, consulter l'information technique P+P26/345.

Saia-Burgess Controls AG

Bahnhofstrasse 18 | CH-3280 Murten | Switzerland

T +41 26 580 30 00 | F +41 26 580 34 99

www.saia-pcd.com | info@saia-pcd.com

Support www.sbc-support.com | support@saia-pcd.com