

## No. 10: Auxiliary Output

The RJ45 connector is located behind the front label; remove the window at AUX INPUT to find the connector.

It is possible connect a temperature sensor, for ambient temperature charging compensation.

With this it is possible to achieve the specifications of the EN54-4 firing norm.

## No. 11: Input AC Voltage connectors

### 6. Thermal behaviour

The rated maximal air temperature @ nominal current is 50 °C. For ambient temperature of above 50 °C, the output current must be reduced by 2.5 % per Kelvin increase in temperature. At the temperature of 70 °C the output current will be  $0.5 \times I_n$ . The equipment does not switch off in case of ambient temperature above 70 °C or thermal overload. The devices are protected for Over temperature conditions "worst case"; in this situations the device Shut-down the output and automatic restart when temperature inside fall.

### 7. Technical Datas

#### Input Data

Nominal input voltage (2 × VAC)	115 / 230 VAC
Input voltage range	90...305 VAC
Inrush current	≤ 11 A / ≤ 5 msec.
Frequency	47...63 Hz
Input current (nominal input voltage)	2.8...1.3 A
Internal fuse	F 4A
External fuse (recommended)	Fast 10A

#### Output Data

Output voltage battery boost charge/nominal current	Max 28.8 VDC/5 A
Output voltage battery trickle charge/nominal current	Max 27.5 VDC/5 A
Adjustment range of charge (In adj)	20...100% I <sub>N</sub>
Output voltage in backup mode	27.5...22 VDC
Type of charging characteristic	I <sub>U</sub> O <sub>U</sub>
End of charging voltage (boost charge)	Max 28.8 VDC
End of charging current (boost charge)	0.3 A
Start up with capacity load	≤ 30.000 mF
Switching on after applying mains voltage	1 sec. max
Nominal current max.	$1.1 \times I_n \pm 5\%$
Continuous current (without battery) I <sub>LOAD</sub> = I <sub>N</sub>	5 A
Continuous current (with battery) I <sub>LOAD</sub> = I <sub>N</sub> + I <sub>BATT</sub>	10 A
Max. current Output Load (Main) I <sub>LOAD</sub> (4 sec.)	15 A max.

Max. current Output Load (Back Up) I <sub>LOAD</sub> (4 sec.)	10 A max.
Residual ripple	≤ 60 mVpp
Minimum load	No
Efficiency	≥ 90 %
Short-circuit protection	Yes
Over load protection	Yes
Over voltage output protection	Yes
Reverse battery protection	Yes

#### Climatic Data

Ambient temperature (operation)	- 25...+ 70 °C
Ambient temperature (storage)	- 40...+ 85 °C
Humidity; no moisture condensation	95 % @ 25 °C

#### General Data

Isolation voltage (input/ output)	3000 VAC
Input ground insulation	1605 VAC
Electrical safety	EN60950
Degree of protection	IP20
Pollution Degree Environment	2
Protection class	I with PE connected
Dimension (wxhxd)	65x115x135
Connection Terminals Blocks:	
Screw Type	2.5 mm
Weight	0.6 kg approx

### 8. Standards and Certification

#### Electrical Safety:

Assembling device: UL508, IEC/EN60950 (VDE0805) and EN50178 (VDE0160)

Isolation according: IEC/EN60950

Input/Output separation: SELV EN60095-1 and PELV EN60204-1.

Double or reinforced insulation

#### EMC Standards (Surge, Transient Immunity):

Immunity: EN61000-4-2, EN61000-4-3, EN61000-4-4, EN61000-4-5, EN61000-4-6, EN61000-6-2

Emission: EN61000-6-4, EN61000-3-2

#### Standards Conformity:

Safety of Electrical Equipment Machines: EN60204-1.

**CE** In according to EMC2004/108/EC and EMC93/68/EEC  
Low voltage directive 2006/95/EU + ROHS 2011/65/EU

**EAC** EAC Mark of Conformity for Machinery Exports to  
Russia, Kazakhstan or Belarus

#### Saia-Burgess Controls AG

Bahnhofstrasse 18 | 3280 Murten, Switzerland  
T +41 26 580 30 00 | F +41 26 580 34 99 | www.saia-pcd.com  
support@saia-pcd.com | www.sbc-support.com

### ► Data sheet

www.sbc-support.com

# Q.PS-ADB-2405-1

## Single phase power supply with intelligent battery charging module

### 1. Technical features

Thanks to the intelligent battery charger (Q.PS-ADB-2405-1), it will be possible to optimise power management. We call "Battery Care" the concept base on algorithms that implement rapid and automatic charging, battery charge optimization during time, flat batteries recovery and real time diagnostic during installation and operation. The Real Time Auto-diagnostic system, monitoring battery faults such as, battery Sulfated, elements in short circuit, accidental reverse polarity connection, disconnection of the battery, they can easily be detected and removed by help of Blink Code of Diagnosis Led; during the installation and after sell. The continuous monitoring of battery efficiency reduces battery damage risk and allows a safe operation in permanent connection. Each device is suited for all battery types, by means of jumpers it is possible setting predefined curves for Open Lead Acid, Sealed Lead Acid, Gel, Ni-Cd, Ni-MH(option).

Before starting with the operations of installation you should consult the manual.

### 2. Rail Mounting

**!** All modules must have a minimum vertical and horizontal distance of 10 cm to this power supply in order to guarantee sufficient auto convection. Depending on the ambient temperature and load of the device, the temperature of the housing can become very high!

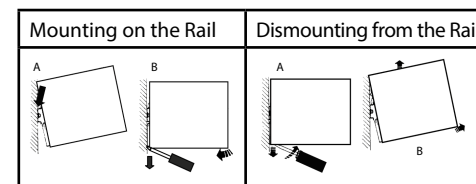

### 3. Cable connection

The following cable cross-sections may be used:

	Solid (mm <sup>2</sup> )	Stranded (mm <sup>2</sup> )	AWG	Torque (Nm)	Stripping Length
Input	0.2÷2.5	0.2÷2.5	24...14	0.5...0.6Nm	7 mm
Output	0.2÷2.5	0.2÷2.5	24...14	0.5...0.6Nm	7 mm
Signal	0.2÷2.5	0.2÷2.5	24...14	0.5...0.6Nm	7 mm

**Input:** The input connection is made by the screw terminals L, N, .

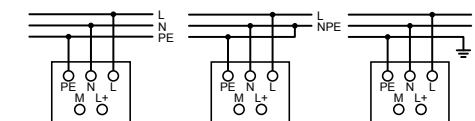

### 4. Safety and warning notes

- !** WARNING – Explosion Hazard. Do not disconnect equipment unless power has been switched off or the area is known to be non-hazardous.
- !** WARNING – Explosion Hazard. Substitution of components may impair suitability for class I, Division 2.
- !** WARNING – Switch off the system before connecting the module. Never work on the machine when it is live. The device must be installed in according with UL508 and EN60950. The device must have a suitable isolating facility outside the power supply unit, via which can be switched to idle. Danger of fatal Injury!

## 5. Operating and Display Elements

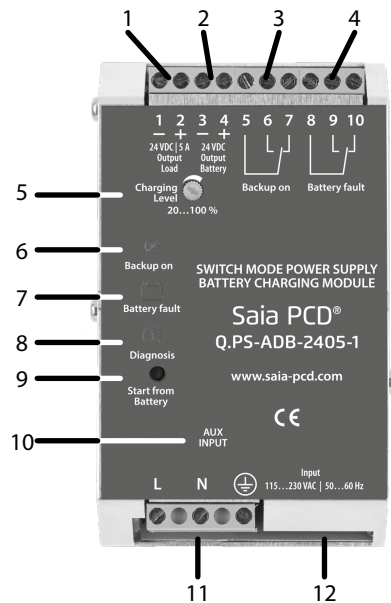

### No. 1: Output Load:

Connect this Output to the load 1 (-) 2 (+).

With Main input ON:

If the Main Input Voltage falls below a Threshold level (50 % of the Typ. Vac input) the battery it is immediately connected to the Output Load, without any interruption of voltage dips: In this situation the voltage in the output load it is the same of the battery.

**To avoid deep battery discharge**, the battery will supply the load supplied until battery voltage reaches 1.5 (1.5 V/cell). Below this level the device automatically switches off to prevent Deep discharge and battery damage.

### No. 2: Battery Connection Port:

Connect the battery between pin. 3 (-) and 4 (+)

### No. 3, 4 Signal Ports (output Isolated):

Connections for,

No. 3: Main/Back Up: Input Main On/Off. Contact: 5, 6, 7

No. 4: Low Battery, Fault connections systems, Battery replacement. Contact: 8, 9, 10

Relay Contact Rating:

Max. DC1: 30 Vdc 1 A; AC1: 60 Vac 1 A: Resistive load (EN60947-4-1)

Min. 1 mA at 5 Vdc: Min. permissive load

Signal Output port true table:		Port N°3 - Led N°6 Main/Back-Up		Port N°4 - Led N°7 Fault Battery	
		5-6 Closed	5-7 Closed	8-9 Closed (OK)	8-10 Closed
Main Input Vac	ON	■ led off		■ led off	
	OFF		■ led On (1)	■ led off	
The battery in BackUP it is less than 30% cap?	YES		■ led On		■ led On
	NO		■ led On	■ led off	
Battery or system Fault?	YES	■ led off			■ led On (2)
	NO	■ led off		■ led off	

Note:

(1) For better efficiency of the system, filter relay Main/Back up with a delay of at least 5 seconds before give alarm Main Lost, example: connection to PLC.

(2) See Diagnosis Led



It is possible set the max recharging current for the batteries by trimmer (Charging Level).

The current adjustment goes from 20 %...100 % of In. Set the maximum charging current between 10% and 20% of the battery capacity.

## No. 6, 7 and 8 Display Signals

No.6: Led Main/Back Up: Input Main On/Off

No.7: Led Low Battery (capacity less than 30%), Fault connections systems and Battery replacement.

No.8: Led Battery charge mode or Led Diagnosis. Diagnosis of the system through "blinking code" signal

Monitoring Control Chart:	State	LED Diagnosis (No.8)	LED Battery Fault (No.7)
Charging Type	Trickle	1 Blink/sec	OFF
	Boost	2 Blink/sec	OFF
	Recovery	5 Blink/sec	OFF
Auto diagnosis of the system	Reverse polarity or high battery Voltage	1 Blink/pause	ON
	Battery No connected	2 Blink/pause	ON
	Element in Short Circuit	3 Blink/pause	ON
	Over Load or short circuit on the load	4 Blink/pause	ON
	Bad battery; Internal impedance Bad or Bad battery wire connection.	5 Blink/pause	ON
	Life test not possible	6 Blink/pause	ON
	Bad thermal sensor	7 Blink/pause	ON
	Boost condition; battery discharge after 4 min. of overload.	8 Blink/pause	ON
	Internal fault	9 Blink/pause	ON
	Low battery. Only if started from battery with no Main input (Form Jumper N°5 or Push Bottom)	10 Blink/pause	ON

### No. 9: Start from Battery, No Main Vac

Push-bottom in the front panel (pressed for 3 sec.) for switch ON the system without the "Main input Vac" and only the battery is connected.

### No. 12: Battery Management Configurations

Completely automatic, all devices are suitable to charge most batteries types thank to the user selectable charging curves. They can charge open lead acid, sealed lead acid, Gel and Ni-Cd, Ni-MH batteries (option).

Caution: Switch off the system before setting the jumper.

Battery Type Selection	Jumper Position	Trickle/Float charge (Volt/Cell)	Fast/Bulk charge (Volt/Cell)	Notice:
Open Lead		2.23	2.40	(1) Option NiCd-NiMH on demand.
Sealed Lead Low		2.25	2.40	⚠ Be careful, in NiCd-NiMH Option, the Sealed Lead High charging curve is deleted. In order to detect end-of-charge negative ΔV, charging current must be set at least at 30% of nominal battery capacity; with lower values of charging current negative ΔV detection is not guaranteed.
Sealed Lead High		2.27	2.40	
Gel Battery		2.30	2.40	
Gel Battery (option) (1)		2.30	2.40	
NiCd - NiMH (option) (1)		10% I <sub>max</sub> Trimmer	1.50	
Functional Setting	Function			
Battery Life test ON		Jumper present: Life test enabled.		(2) Do not leave the jumper in position 5; penalty discharge, in Back up mode, completely the battery close to Zero.
Fast Charge Enable		Jumper present: Fast charge enabled.		
Battery Start (2)		Via cable for connection to external Push bottom mounted on front Panel of the external system.		