





Q.PS-AD2-2402F



Power supplies with 24 VDC output

- Input rated voltage 115...230 VAC
- Output: 24 VDC $\pm 3\%$ / 2.5 A
- Power Boost: 3.5 A for at least 3 minutes, up to 60 °C
- Short-circuit protection
- Overload protection
- Strong overload without switch-off
- IP 20
- Mounting on DIN rail
- Extremely small size

| Figure | Input | Output | Protection | Features |
|--|---|---|--|---|
|  Q.PS-AD1 | Single phase 24 VAC / 40 VDC | 24 VDC, 3 A 24 VDC, 5 A 24 VDC, 7 A | Short circuit Overload | |
|  Q.PS-AD2-24xxF | Single phase 115 / 230 VAC | 24 VDC, 1,5...3 A 24 VDC, 5...7.5 A 24 VDC, 10...14 A | Short circuit Overload Overvoltage | Adjustable output voltage 22...27 VDC |
|  Q.PS-AD3 | Double-phase 230 / 400...500 VAC | 24 VDC, 5...7.5 A | Short circuit Overload Overvoltage | Adjustable output voltage 22...26 VDC |
|  Q.PS-ADB | Single phase 115 / 230 VAC / 24 VDC battery | 24 VDC, 5 A | Short circuit Overload Overvoltage | Adjustable charging current 1...5 A, battery diagnostic and different charging modes |

Applications

Control panels, where 24 VDC is required to supply PLC's, actors, sensors etc. But also power demanding loads such as solenoid valves, motors, lamps, etc. Can be used in applications for:

- Building automation
- Industrial automation
- Infrastructure plants, such as water or sewage treatment
- Machineries
- Material handling
- etc.

Functions

Q.PS-AD2-2402F

| Input data | |
|--|--|
| Input voltage | 115...230 VAC |
| Input Voltage Range | 90...264 VAC |
| Inrush Current (at U_n and I_n) | $\leq 7 A \leq 5 ms$ |
| Frequency | 47...63 Hz $\pm 6\%$ |
| Input Current (Input Rated Voltage) | 1.0...0.7 A |
| Internal Fuse | 4 A |
| External Fuse | Fast 6 A |
| Output data | |
| Output Voltage (U_o) / Nominal Current (I_n) | 24 VDC $\pm 3\%$ / 2.5 A |
| Adjustment range (U_{adj}) | 22...27 VDC |
| Turn-On delay after applying mains voltage | 2 s (max.) |
| Start up with capacitive load | $\leq 50.000 \mu F$ |
| Continuous running current | |
| Max. continuous current at $\leq 40^\circ C$ | 2 A (115 VAC), 3 A (230 VAC) |
| Max. continuous current at $\leq 50^\circ C$ | 1.5 A (115 VAC), 2.5 A (230 VAC) |
| Power reserve (power boost) (within 3 min. $\leq 60^\circ C$) | 3,5 A |
| Short-circuit current (I_{cc}) | 7 A |
| Hold-up Time (at 100...240 VAC) | in general 20 ms |
| Residual Ripple | $\leq 80 mV_{pp}$ |
| Minimum load | No |
| Efficiency (at 50% I_n) | $\geq 88\%$ |
| Short-circuit protection | Yes |
| Overload protection | Yes |
| Over Voltage Output protection | Yes (max 35 VDC) |
| Parallel connection | Yes |
| Climatic data | |
| Ambient Temperature (operation) | -25...+70 °C (Derating $>50^\circ C$, 2,5%/°C) |
| Ambient Temperature (storage) | -40... +85 °C |
| Humidity; no moisture condensation | 95% at +25°C |
| General data | |
| Isolation Voltage (Input/Output) | 3000 VAC |
| Input / Ground isolation PE | 1605 VAC |
| Output / Ground isolation PE | 500 VAC |
| Degree of protection | IP 20 |
| Pollution Degree Environment | 2 |
| Protection class | I, with PE connected |
| Dimension ($w \times h \times d$) | 50 \times 120 \times 50 mm |
| Weight | approx 0.30 kg |

Output characteristics

Output Derating Curve

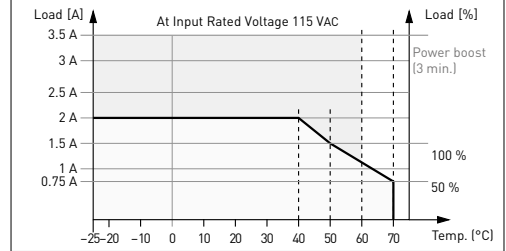
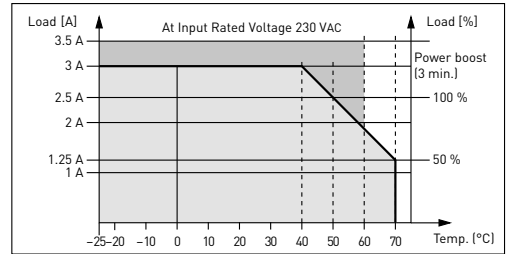

Output Characteristic Curve U/I

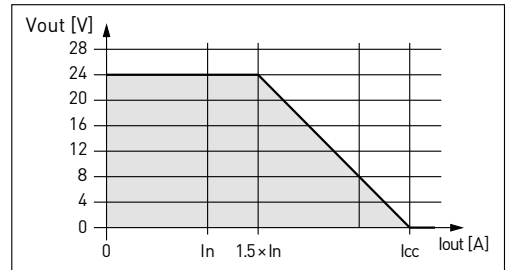

Dimensions

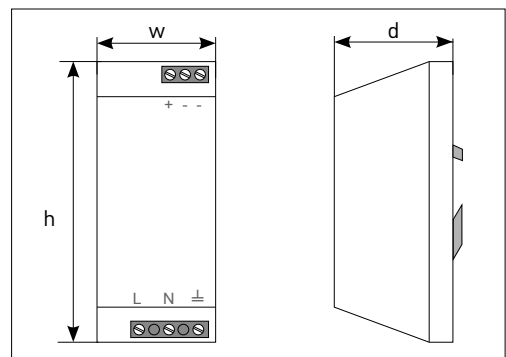

Saia-Burgess Controls AG

Bahnhofstrasse 18 | 3280 Murten, Switzerland | T +41 26 580 30 00 | F +41 26 580 34 99 | www.saia-pcd.com

support@saia-pcd.com | www.sbc-support.com

Instruction manual 4 319 5131 0e 09.2015 Subjects to change without notice.

1 Phase Power supplies Q.PS-AD2-24xxF

Primary switched power supply

Thank you for having chosen one of our products for your work. We are certain that it will give the utmost satisfaction and be a notable help on the job.

Application

The power supplies Q.PS-AD2-24xxF can be used in areas with extreme industrial environment, and complies with the latest technical standard. Before working with the unit, read these instructions carefully and completely. All these power supplies are single output, IP20 and have Mounting DIN Rail IEC60715/TH35. Class 1 isolation devices suitable for SELV and PELV solutions.

Connection

The following cable cross-sections may be used:

| | Solid (mm ²) | Stranded (mm ²) | AWG | Torque (Nm) | Stripping Length |
|--------|--------------------------|-----------------------------|-----------|-------------|------------------|
| Input | 0.2÷2.5 | 0.2÷2.5 | 24 ... 14 | 0.5...0.6Nm | 7 mm |
| Output | 0.2÷2.5 | 0.2÷2.5 | 24 ... 14 | 0.5...0.6Nm | 7 mm |
| Signal | 0.2÷2.5 | 0.2÷2.5 | 24 ... 14 | 0.5...0.6Nm | 7 mm |

Signalling

| Jumper Settings | Standard Conditions "LED VDC ok" | Overflow conditions "LED VDC ok" |
|---------------------|--|--|
| MANUAL RESET | Lights up permanently when the output voltage is OK. | Switches off when there is an overload |
| HICCUP MODE | | Blinks when there is an overload |
| CONTINUOUS OUT MODE | | Switches off when there is an overload |

Rail Mounting

Mounting on the Rail

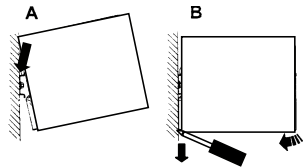

Dismounting from the Rail

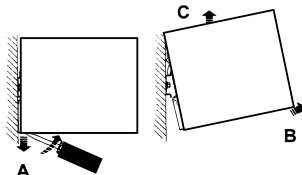

With PLASTIC Hook



Other modules must have a minimum vertical distance of 10 cm to this power supply in order to guarantee sufficient auto convection. Depending on the ambient temperature and load of the device, the temperature of the housing can become very high!

Installation

WARNING!



Explosion Hazard! Do not disconnect equipment unless power has been switched off or the area is known to be non-hazardous.

Explosion Hazard! Substitution of components may impair suitability for class I, Division 2. Switch off the system before connecting the module. Never work on the machine when it is live. The device must be installed in according with EN60950. The device must have a suitable isolating facility outside the power supply unit, via which can be switched to idle. Danger of fatal Injury!

The connection is made by screw type 2.5 mm² terminal blocks. Use only copper cables that are designed for operating temperatures of >75 °C. Wiring terminals shall be marked to indicate the proper connection for the power supply.

Input: The input connection is made by L, N, 
Output: 24 VDC is made via the + (+), - (-).

Protection

On the primary side: the device is equipped with an internally fuse. If the internal fuse is activated, it is most probable that there is a fault in the device. If happen, the device must be checked in the factory.
 On the secondary side: the device is electrically protected against: Over-load, output over-voltage and short circuit automatically. It is not possible to set the overload mode on the Q.PS-AD2-2402F.

Connection

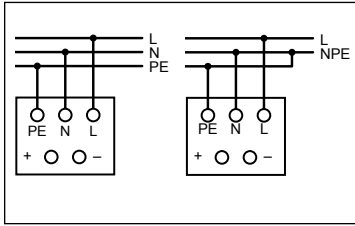

Parallel Connection for increased capacity

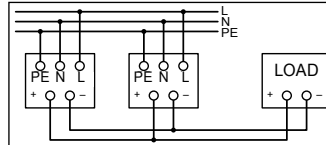

With Q.PS-AD2-2402F and Q.PS-AD2-2405F

To result a good current share between all devices in parallel, adjust the output voltage in a tolerance of ± 20 mV. Therefore applying 1...2 A load to adjust the output voltage. Then connect them in parallel. Use only power supplies of the same model.



With Q.PS-AD2-2410F

Change the jumper position to enable the "Easy parallel connection"



Easy Parallel connection OFF
(factory selection)



Easy Parallel connection ON
In this mode it can be put up to 4 power supply in parallel

Characteristic Curves

Short circuit and overload

The output of the device is electrically protected against overload and short circuit. At nominal voltage the device can supply 1.5 the nominal Current without switching off. In the case of higher overload, the operating point traces the curve illustrated in figure. As the overload increases, the output voltage is reduced until zero.

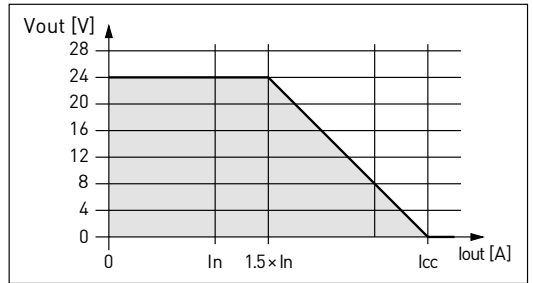

Thermal behaviour

The rated maximal air temperature @ nominal current is 60 °C (the Q.PS-AD2-2402F 50 °C). For ambient temperature above 60 °C, the output current must be reduced by 2.5% per Kelvin increase in temperature. At the temperature of 70 °C, the output current will be $3/4 \times I_n$ (by the Q.PS-AD2-2402F $I_n/2$). The equipment does not switch off in case of ambient temperature up to 70 °C or thermal overload. The devices are protected for excess temperature conditions. In conditions where the power-supply inside temperature is over 70 °C will the device shut-down the output and will be automatically restarted when the temperature inside the power-supply is decreased.

Standards and Certification

Electrical Safety:

Assembling device: UL508, IEC/EN60950 (VDE0805) and EN50178 (VDE0160)

Isolation according: IEC/EN60950

Input/Output separation: SELV EN60095-1 and PELV EN60204-1. Double or reinforced insulation

EMC Standards (Surge, Transient Immunity):

Immunity: EN61000-4-2, EN61000-4-3, EN61000-4-4, EN61000-4-5, EN61000-4-6, EN61000-6-2

Emission: EN61000-6-4, EN61000-3-2

Standards Conformity:

Safety of Electrical Equipment Machines: EN60204-1.



In according to EMC2004/108/EC and EMC93/68/EEC
Low voltage directive 2006/95/EU + ROHS 2011/65/EU



EAC Mark of Conformity for Machinery Exports to
Russia, Kazakhstan or Belarus