

HPCD3.C200

Extension module holder for 4 I/O modules

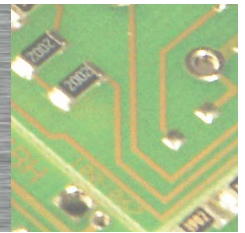

Description

The HPCD3.M6893 controllers can be expanded with HPCD3.Cxxx components, making additional module sockets available. On the HPCD3.M6893, up to 15 HPCD3.Cxxx module holders can be attached. This allows the user to attach a maximum of 64 I/O modules, or 1023 digital inputs/ outputs.

HPCD3.C200 serves as a bus repeater and internally provides + 5 V and V + for a segment of I/O modules.

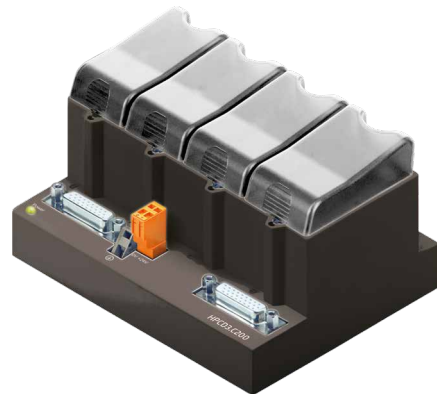

HPCD3.C200

Device design

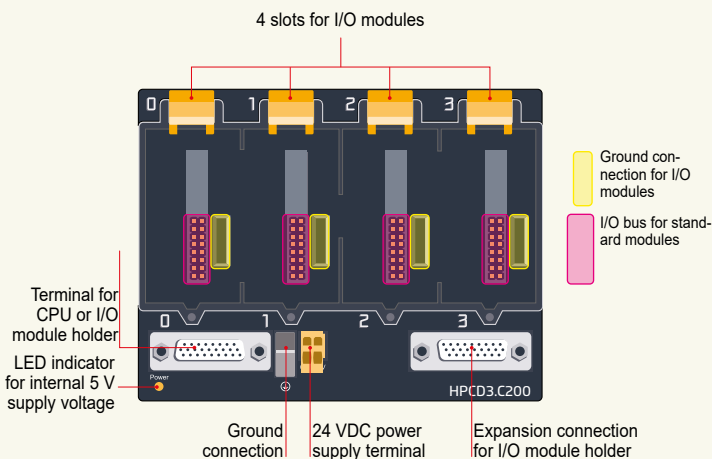

All standard I/O modules can be used in the expansion module holders. Communication modules or other intelligent modules can only be used in the slots of the Basic CPU.

Example calculation for the current consumption of the internal +5V and +V (24V) bus of the I/O modules

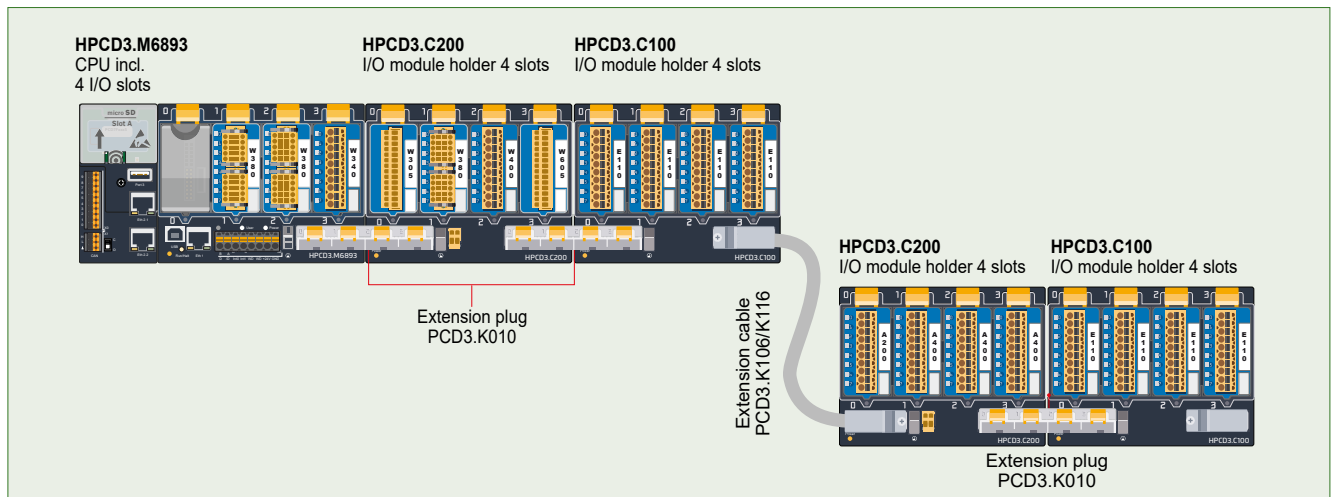

Dimension Drawing HPCD3.C200

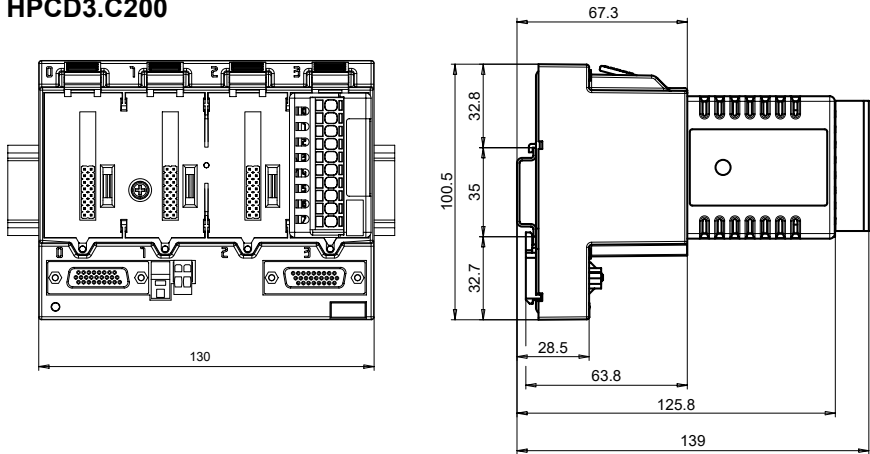

Easy assembly of the module holders on DIN rail (1 × 35 mm)

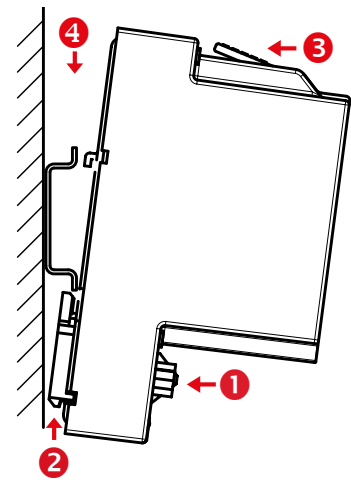

- 1 Press lower part of housing onto mounting rail
 - 2 Push up against the spring force up to the stop
 - 3 Hook in over the upper edge of the mounting rail and yield to the spring force
 - 4 For safety, push the housing into the mounting rail from top to bottom
- Check if the device is securely fixed.

Connections of the HPCD3.C200

Bus connection from CPU or module carrier Bus connection to module carrier

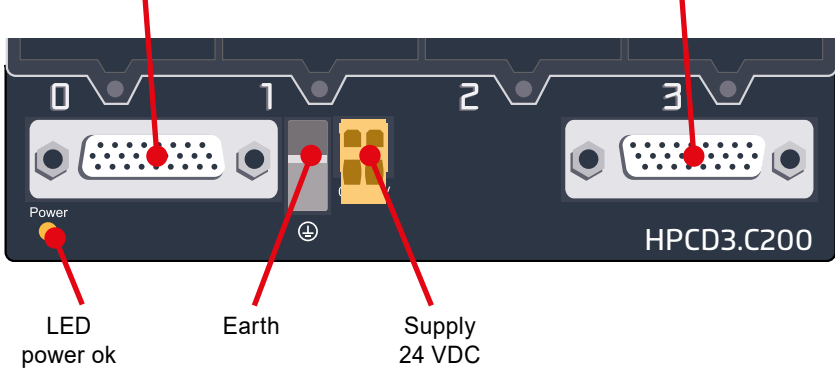

Dismounting from DIN rail

To remove the housing, push upwards and pull out.

Technical data		
Number of module slots	4	
Description	4 I/O modules	
External power supply (maximum load see below)	24 VDC	
Load capacity from +5 V bus HW versions A and B	1000 mA	
Load capacity from +5 V bus Starting with HW version C	1500 mA	
Load capacity from V+ bus HW versions A and B	100 mA	
Load capacity from V+ bus Starting with HW version C	24 VDC -25...+30%	200 mA
	24 VDC -20...+25%	310 mA – $\frac{I+5V}{15}$ mA
	24 VDC -10...+10%	630 mA – $\frac{I+5V}{3.8}$ mA

Internal supply of the LIO module carrier HPCD3.C200

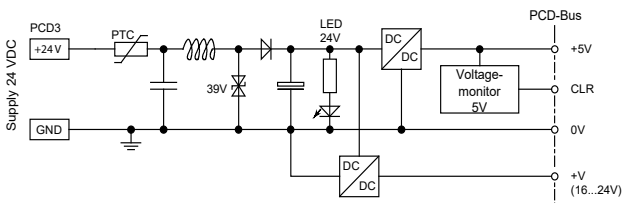

When planning HPCD3 systems, it must be checked whether the two internal power supplies are not overloaded. This control is especially important when using analog, counting, and positioning and other special modules, as some of them consume a relatively large amount of power.

Insertion of I/O modules

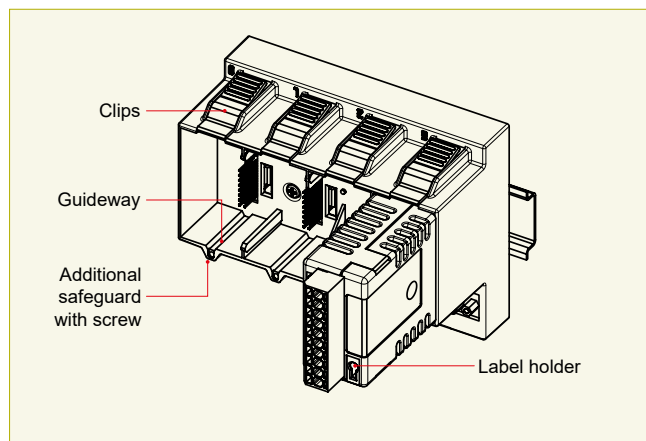

▲ Simple exchange of I/O modules

Over 40 modules available with different functionalities

Types

- ▶ **PCD3.Axxx** Digital output modules
- ▶ **PCD3.Exxx** Digital input modules
- ▶ **PCD3.Fxxx** Communication modules
- ▶ **PCD3.Wxxx** Analogue input/output modules



The HPCD3.C200 is used to extend the I/O bus or for the internal power supply +5V and +V (24V) to a module segment.

Please note the following rules:

- **Mandatory:** Insert a HPCD3.C200 after the HPCD3.M6893 and after each cable (at the start of a row).
- Do not use more than six HPCD3.C200 in a single configuration, or the time delay will exceed the I/O access time. Use a maximum of five PCD3.K106/K116 cables.
- If an application is mounted in a single row (max. 15 module holders), then after five HPCD3.C100 a HPCD3.C200 must be used to amplify the bus signal (unless the configuration ends with the fifth HPCD3.C100).
- If the application is mounted in multiple rows, the restricted length of cable means that only three module holders (1× HPCD3.C200 and 2× HPCD3.C100) may be mounted in one row.



HPCD3 I/O modules are not hot-plug capable:

- Carefully insert and remove the I/O modules after switching off the power supply (24V).



The following aspects should be considered when planning HPCD3 applications:

- In keeping with lean automation, it is recommended to leave the first slot in the CPU basic module free for any subsequent expansions. This slot can accommodate simple I/O modules but also communication modules.
- The total length of the I/O bus is limited by technical factors; the shorter, the better.



I/O modules and I/O terminal blocks may only be plugged in and removed when the Control Edge PCD and the external +24 V are disconnected from the power supply.

Consumption M6893 + C200 + C100

Module	Internal 5V	Internal +V (24V)
Not used		
W380	25 mA	25 mA
W380	25 mA	25 mA
W340	8 mA	20 mA
Total M6893	58 mA	70 mA
W340	8 mA	20 mA
W340	8 mA	20 mA
W610	110 mA	0 mA
E160	10 mA	
Total C200	136 mA	40 mA
E160	10 mA	
E160	10 mA	
E160	10 mA	
E160	10 mA	
Total C100	40 mA	0
Total C200	176 mA	40 mA

Consumption C200 + C100

Module	Internal 5V	Internal +V (24V)
A200	15 mA	
A810	40 mA	
A810	40 mA	
A860	18 mA	
Total C200	113 mA	
A460	10 mA	
A460	10 mA	
A460	10 mA	
W380	25 mA	25 mA
Total C100	55 mA	25 mA
Total C200	168 mA	25 mA

Capacity	HPCD3.M6893	HPCD3.C200
Internal 5V	600 mA	1500 mA
Internal +V (24V)	100 mA	200 mA

The calculation example shows that internal capacity is maintained in the CPU basic module HPCD3.M6895 and the holder module HPCD3.C200. The CPU basic module has a sufficient reserve to receive an additional communication module in the empty slot 0. The holder module HPCD3.C200 also has sufficient reserves to connect an additional HPCD3.C100 holder module. The power consumption of the internal +5V and +V (24 V) bus for the I/O modules can be calculated in the Control Edge PCD IO-Calculator Excel sheet.

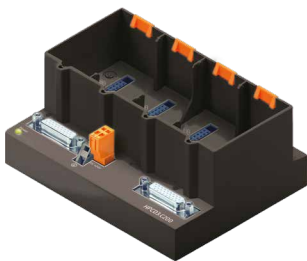

PCD3.C200



Slot cover
32347605-001



Screw terminal
2-pole
440549520



Connecting plug
PCD3.K010



Extension cable 0.7 / 1.2 m
PCD3.K106 / PCD3.K116

Ordering information

Type	Short description	Description	Weight
HPCD3.C200	PCD3.C100 for 4 modules	Extension module holder for 4 I/O modules	440 g

Accessories

Type	Short description	Description	Weight
32347605-001	Slot cover	Slot cover for unused HPCD3 I/O slots	8 g
440549520	Screw terminal 2-pole	Plug-in screw terminal block, 2-pole up to 2.5 mm ² (orange block) for HPCD3.C200	15 g
PCD3.K010	Connection plug	Connection plug HPCD3.M/T/C to HPCD3.Cx00	40 g
PCD3.K106	Extension cable 0.7 m	Extension cable for HPCD3.M/T/C to HPCD3.Cx00 (length 0.7 m)	140 g
PCD3.K116	Extension cable 1.2 m	Extension cable for HPCD3.M/T/C to HPCD3.Cx00 (length 1.2 m)	180 g

**ATTENTION**

These devices must only be installed by a professional electrician, otherwise there is the risk of fire or the risk of an electric shock.

**WARNING**

Product is not intended to be used in safety critical applications, using it in safety critical applications is unsafe.

**WARNING - SAFETY**

The unit is not suitable for the explosion-proof areas and the areas of use excluded in EN61010 Part 1.

**WARNING - SAFETY**

Check compliance with nominal voltage before commissioning the device (see type label). Check that connection cables are free from damage and that, when wiring up the device, they are not connected to voltage. Do not use a damaged device !

**NOTE**

In order to avoid moisture in the device due to condensate build-up, acclimatise the device at room temperature for about half an hour before connecting.

**CLEANING**

The device can be cleaned in dead state with a dry cloth or cloth soaked in soap solution. Do not use caustic or solvent-containing substances for cleaning.

**MAINTENANCE**

These devices are maintenance-free.
If damaged during, no repairs should be undertaken by the user.



Observe this instructions (data sheet) and keep them in a safe place.
Pass on the instructions (data sheet) to any future user.

**WEEE Directive 2012/19/EC Waste Electrical and Electronic Equipment directive**

The product should not be disposed of with other household waste. Check for the nearest authorized collection centers or authorized recyclers. The correct disposal of end-of-life equipment will help prevent potential negative consequences for the environment and human health.



EAC Mark of Conformity for Machinery Exports to Russia, Kazakhstan or Belarus.

Sales and Service

For application assistance, current specifications, pricing, or name of the nearest Authorized Distributor, contact one of the offices below.

ASIA PACIFIC

Honeywell Process Solutions,
(TAC) hfs-tac-support@honeywell.com

Australia

Honeywell Limited
Phone: +(61) 7-3846 1255
FAX: +(61) 7-3840 6481
Toll Free 1300-36-39-36
Toll Free Fax:
1300-36-04-70

China – PRC - Shanghai

Honeywell China Inc.
Phone: (86-21) 5257-4568
Fax: (86-21) 6237-2826

Singapore

Honeywell Pte Ltd.
Phone: +(65) 6580 3278
Fax: +(65) 6445-3033

South Korea

Honeywell Korea Co Ltd
Phone: +(822) 799 6114
Fax: +(822) 792 9015

EMEA

Honeywell Process Solutions,
Phone: +80012026455 or
+44 (0)1344 656000

Email: (Sales)
FP-Sales-Apps@Honeywell.com
or
(TAC) hfs-tac-support@honeywell.com

AMERICA'S

Honeywell Process Solutions,
Phone: (TAC) 1-800-423-9883 or
215/641-3610
(Sales) 1-800-343-0228

Email: (Sales)
FP-Sales-Apps@Honeywell.com
or
(TAC) hfs-tac-support@honeywell.com

WARRANTY/REMEDY

Honeywell warrants goods of its manufacture as being free of defective materials and faulty workmanship. Contact your local sales office for warranty information. If warranted goods are returned to Honeywell during the period of coverage, Honeywell will repair or replace without charge those items it finds defective. The foregoing is Buyer's sole remedy and is **in lieu of all other warranties, expressed or implied, including those of merchantability and fitness for a particular purpose.** Specifications may change without notice. The information we supply is believed to be accurate and reliable as of this printing. However, we assume no responsibility for its use.

While we provide application assistance personally, through our literature and the Honeywell web site, it is up to the customer to determine the suitability of the product in the application.

Specifications are subject to change without notice.

For more information

Learn more about ControlEdge PCD, visit our website www.honeywellprocess.com/ControlEdgePCD or contact your Honeywell account manager.

Honeywell Process Solutions

2101 CityWest Blvd, Houston TX 77042
Honeywell House, Skimped Hill Lane

Bracknell, Berkshire, England RG12 1EB UK ©2020 Honeywell International Inc.
Building #1, 555 Huanke Road,

Zhangjiang Hi-Tech Industrial Park,
Pudong New Area, Shanghai 201203

Document No.: 51-52-03-51
Rev.3.1
July 2020

