

PCD7.LRxx BACnet Room Controller

GENERAL

The PCD7.LRXX BACNET Room Controllers family provide flexible, configurable, demand-led control that delivers tangible benefits to reduce energy spends and drives new levels of functionality and efficiency in today’s buildings. The BACnet MS/TP-based room controllers includes a configurable application supporting fan coil unit, chilled and hot ceiling as well as radiator heating applications. It is even possible to handle a mix of these applications in one controller.

Line voltage or 24VAC power supply and the flexible use of relays and triacs (24 VAC or 230 VAC), 24 VAC power supply for field devices, Sylk wall modules, and smart engineering and commissioning tools reduce the total installed cost.

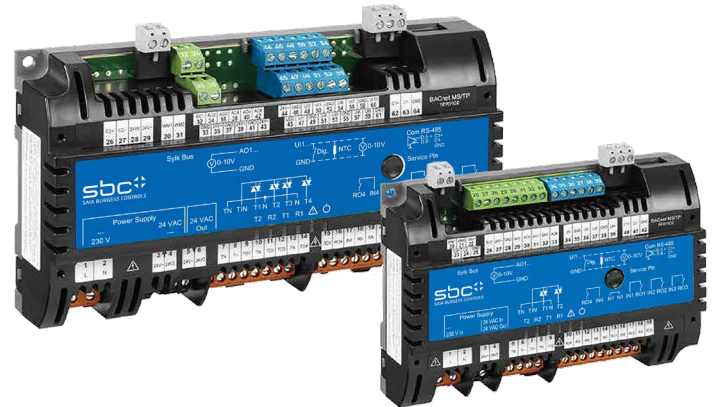

Fig. 1. PCD7.LRxx (without optional covers)

FEATURES

- ▶ Designed to control terminal units such as 2- and 4-pipe fan coil units, chilled and hot ceilings, hydronic heating, and a mix of these applications.
- ▶ Support for 1-3 stage fans, variable fan speed drives (VSDs), thermal, floating, proportional actuators, and 6-way valve actuators (see section “Commissioning”, pg. 7).
- ▶ Auto Mac-addressing.
- ▶ Fast commissioning using plug-and-play solutions, pre-defined applications and state-of-the-art commissioning via the ROOMUP mobile application – eliminating the need for two people when commissioning.
- ▶ Reduced number of sensors because sensors are shared across different applications.
- ▶ BACnet BTL®-Listed as Advanced Application Controllers (B-AAC) rev 1.12.
- ▶ Two housing dimensions and several different I/O versions to match your individual needs.
- ▶ Universal mounting options, including terminal covers and color-coded terminals.
- ▶ The 230 VAC models feature 24 VAC aux. output voltage, allowing direct connection and powering of field devices
- ▶ Two-wire polarity-insensitive bus interface to connect to Honeywell Sylk wall modules.

SYSTEM OVERVIEW

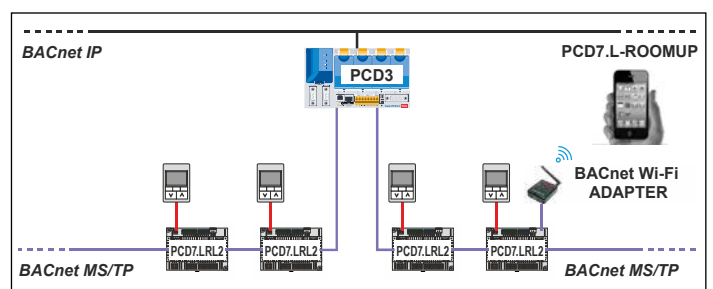

Fig. 2. PCD7.LRL2 Example

Table 1. Overview of models

Article number	Housing	Power supply	Analogue outputs AOs	Universal inputs UIs	Relays	Triacs (24/230 VAC)	Total no. of I/O	24 VAC output for field devices and Triac outputs	Comment
PCD7.LRL2	Large	230 VAC	2	6	4	4	16	max 300 mA	fixed terminals, except BACnet MS/TP, Sylk and 24VAC power supply terminals which are removable
PCD7.LRS4	Small	230 VAC	4	4	4	2	14	max 300 mA	
PCD7.LRS5	Small	24 VAC	4	4	4	2	14	max 600 mA	

DIMENSIONS AND MOUNTING

Housings

The controller is available in two housing sizes, both conforming to IP20:

- ▶ PCD7.LRL2 (large housing):
W × L × H = 110 × 198 × 59 mm and
- ▶ PCD7.LRSx (small housing):
W × L × H = 110 × 162 × 59 mm

See also Fig. 3 and Fig. 4.

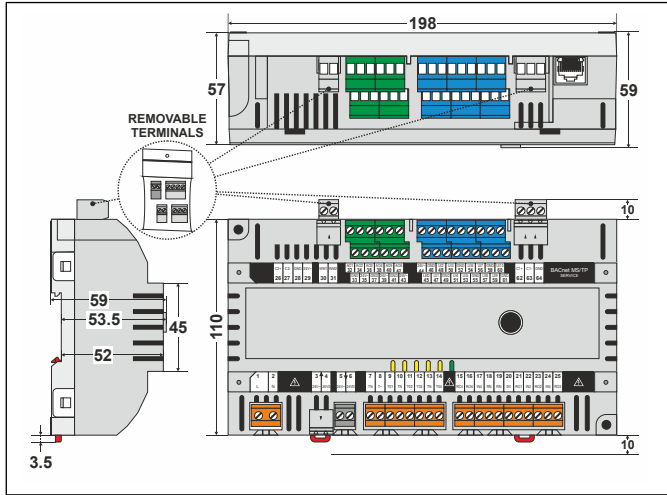

Fig. 3. PCD7.LRL2 dimensions (in mm)

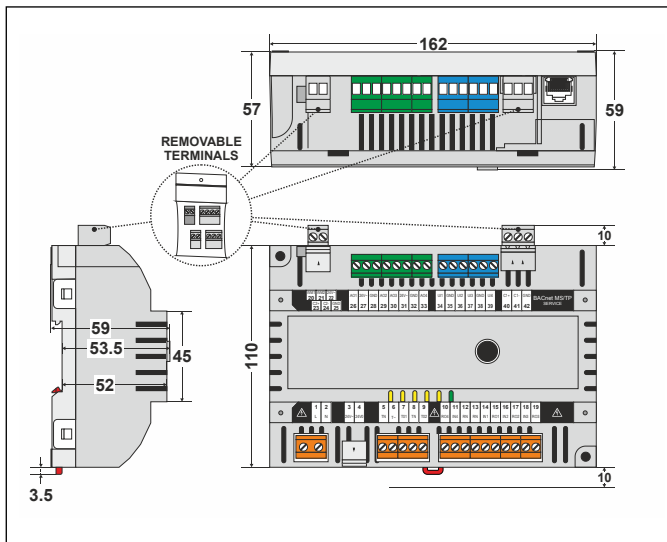

Fig. 4. PCD7.LRSx dimensions (in mm)

The unit is suitable for mounting on a standard rail, on walls, as well as in wiring cabinets or fuse boxes.

Terminal Protection Covers for IP30

In the case of controllers mounted outside of a cabinet, before applying power to the device, Terminal Protection Covers (10-pc. bulk packs, order no.: IRM-RLC for large housings and IRM-RSC for small housings) must be mounted so as to provide IP30.

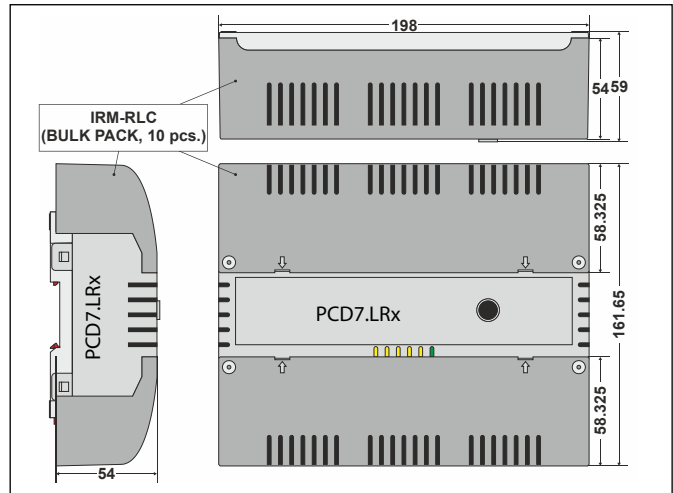

Fig. 5. Large housing, with terminal protection covers, dimensions (in mm)

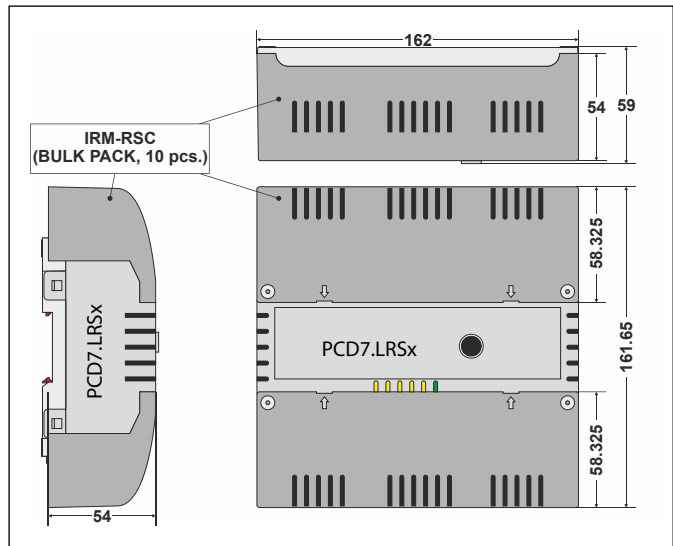

Fig. 6. Small housing, with terminal protection covers, dimensions (in mm)

TERMINAL ASSIGNMENT

General

For a complete list of all terminals and a description of their functions, see Table 2 and Table 6.

Communication Interfaces

All models of the controller features the following communication interfaces:

- ▶ A Sylk Bus interface for connection to TR40, TR40-CO2, TR42 and TR42-CO2 Wall Modules;
- ▶ A BACnet MS/TP interface;
- ▶ An RJ-45 connector for connection of the BACnet WiFi Adapter.

Table 2. PCD7.LRSx Room Controller: Overview of terminals and functions

term.	printing	function	RS4	RS5
1, 2	„L“, „N“	230-V power supply	X	---
3, 4	„24V~“, „24V0“	Removable 24-V power supply input	---	X
3, 4	„24V~“, „24V0“	Aux. output voltage (24 VAC) for all triacs	X	---
5	„TN“	Aux. term. for triac neutral wiring (internally connected with terminal 8)	X	X
6	„T~“	Triac input voltage (24 VAC / 230 VAC) for all triacs; triac-switched	X	X
7	„T01“	Triac-switched output	X	X
8	„TN“	Aux. term. for triac neutral wiring (internally connected with terminal 5)	X	X
9	„T02“	Triac-switched output	X	X
10, 11	„RO4“, „IN4“	Output of Relay 4, Input for Relay 4	type 2	type 2
12, 13	„RN“, „RN“	Aux. terminals for relay neutral wiring	X	X
14, 15	„IN1“, „RO1“	Input for Relay 1, Output of Relay 1	type 1	type 1
16, 17	„IN2“, „RO2“	Input for Relay 2, Output of Relay 2	type 1	type 1
18, 19	„IN3“, „RO3“	Input for Relay 3, Output of Relay 3	type 1	type 1
20, 21	„WM1“, „WM2“	Removable interface for Sylk Bus	X	X
22, 23, 24, 25	„24V~“, „C2+“, „C2-“, „GND“	Not used	---	---
26	„AO1“	Analog Output 1	type 2	type 2
27	„24V~“	24 VAC power for field devices	X	X
28	„GND“	Ground for AOs	X	X
29	„AO2“	Analog Output 2	type 1	type 1
30	„AO3“	Analog Output 3	type 1	type 1
31	„24V~“	24 VAC power for field devices	X	X
32	„GND“	Ground for AOs	X	X
33	„AO4“	Analog Output 4	type 1	type 1
34	„UI1“	Universal Input 1	X	X
35	„GND“	Ground for UIs	X	X
36	„UI2“	Universal Input 2	X	X
37	„UI3“	Universal Input 3	X	X
38	„GND“	Ground for UIs	X	X
39	„UI4“	Universal Input 4	X	X
40, 41, 42	„C1+“, „C1-“, „GND“	Removable BACnet MS/TP interface and corresponding GND	X	X

Relay output types: See Table3. Universal input types: See Table 4. Analog output types: See Table 5

Table 3. Relay output types and characteristics

	type 1 (standard)	type 2 (high in-rush current)
corresponding ROs of RSxx	RO1, RO2, RO3	RO4
corresponding ROs of RLxx	RO2, RO3	RO1, RO4
contact	N.O.	N.O.
min. load	5 VAC, 100 mA	24 VAC, 40 mA
switching voltage range	15...253 VAC	15...253 VAC
max. continuous load at 250 VAC (cos φ = 1)	4 A	10 A
max. continuous load at 250 VAC (cos φ = 0.6)	4 A	10 A
in-rush current (20 ms)	---	80 A
usage	fan motor	light switching and fan motor

NOTE: The max. sum load of all relay currents at the same time is 14 A.

Table 4. Analog output types and characteristics

	type 1	type 2	type 3
output voltage	0...11 V		
output current	0...1 mA	0...5 mA	0...10 mA
min. accuracy	±150 mV		
max. ripple	±100 mV		
accuracy at zero point	0...200 mV		

Table 5. Universal input types and characteristics

	UI1, UI2, UI3, UI4, UI5, UI6
pull-up voltage: 10 V	X
NTC10kΩ	X
NTC20kΩ	X
dry contact (closed: res. <10 kΩ; open: res. > 20 kΩ; max. 0.2 Hz; pull-up voltage: 10 V)	X
fast binary (=counter) input (max. 30 Hz; pulse ON = min. 16 ms; pulse OFF = min. 16 ms; closed: voltage < 1 V; open: voltage > 5 V; pull-up voltage: 10 V)	X
SetPoint and FanSpdSW (from PCD7.L63x, Q.RCU-A-Txxx and T7460x)	X

Table 6. PCD7.RLxx Room Controllers: Overview of terminals and functions (by model)

term.	printing	function	RL2
1, 2	"L", "N"	230-V power supply	X
3, 4	"24V~", "24V0"	Removable 24-V power supply input	---
5, 6	"24V~", "24V0"	Aux. output voltage (24 VAC) for all triacs	X
7	"TN"	Aux. terminal for triac neutral wiring (internally connected with terminals 10 + 13)	X
8	"T~"	Triac input voltage (24 VAC / 230 VAC) for all triacs; triac-switched	X
9	"T01"	Triac-switched output	X
10	"TN"	Aux. terminal for triac neutral wiring (internally connected with terminals 7 + 13)	X
11	"T02"	Triac-switched output	X
12	"T03"	Triac-switched output	X
13	"TN"	Aux. terminal for triac neutral wiring (internally connected with terminals 7 + 10)	X
14	"T04"	Triac-switched output	X
15	"RC4"	Triac-switched output	---
16, 17	"RO4", "IN4"	Output of Relay 4, Input for Relay 4	type 2
18	"RN"	Aux. terminal for relay neutral wiring	X
19	"RN"	Aux. terminal for relay neutral wiring	X
20, 21	"IN1", "RO1"	Input for Relay 1, Output of Relay 1	type 2
22, 23	"IN2", "RO2"	Input for Relay 2, Output of Relay 2	type 1
24, 25	"IN3", "RO3"	Input for Relay 3, Output of Relay 3	type 1
26, 27, 28, 29	"C2+", "C2-" "GND", "24V~"	RS-485 Modbus interface, corr. GND, + aux. power (24 VAC ±20%, 50/60 Hz)	---
30, 31	"WM1", "WM2"	Removable interface for Sylk Bus	X
32	"AO1"	Analog Output 1	type 3
33	"GND"	Ground for AOs	X
34	"AO2"	Analog Output 2	type 3
35	"24V~"	24 VAC power for field devices	X
36	"AO3"	Analog Output 3	---
37	"GND"	Ground for AOs	---
38	"AO4"	Analog Output 4	---
39	"24V~"	24 VAC power for field devices	---
40	"AO5"	Analog Output 5	---
41	"GND"	Ground for AOs	---
42	"AO6"	Analog Output 6	---
43	"24V~"	24 VAC power for field devices	---
44	"24V~"	24 VAC power for field devices	X
45	"LED"	Output to LED of PCD7.L632, Q.RCU-A-TSOx and T7460C,E,F	X
46	"GND"	Ground for Uls	X
47	"UI1"	Universal Input 1	type 1
48	"UI2"	Universal Input 2	type 2
49	"GND"	Ground for Uls	X
50	"UI3"	Universal Input 3	type 1
51	"UI4"	Universal Input 4	type 1
52	"GND"	Ground for Uls	X
53	"UI5"	Universal Input 5	type 1
54	"UI6"	Universal Input 6	type 1
55	"GND"	Ground for Uls	X
56	"UI7"	Universal Input 7	---
57	"UI8"	Universal Input 8	---
58	"GND"	Ground for Uls	---
59	"UI9"	Universal Input 9	---
60	"UI10"	Universal Input 10	---
61	"GND"	Ground for Uls	---
62, 63, 64	"C1+", "C1-", "GND"	Removable BACnet MS/TP interface and corresponding GND	X

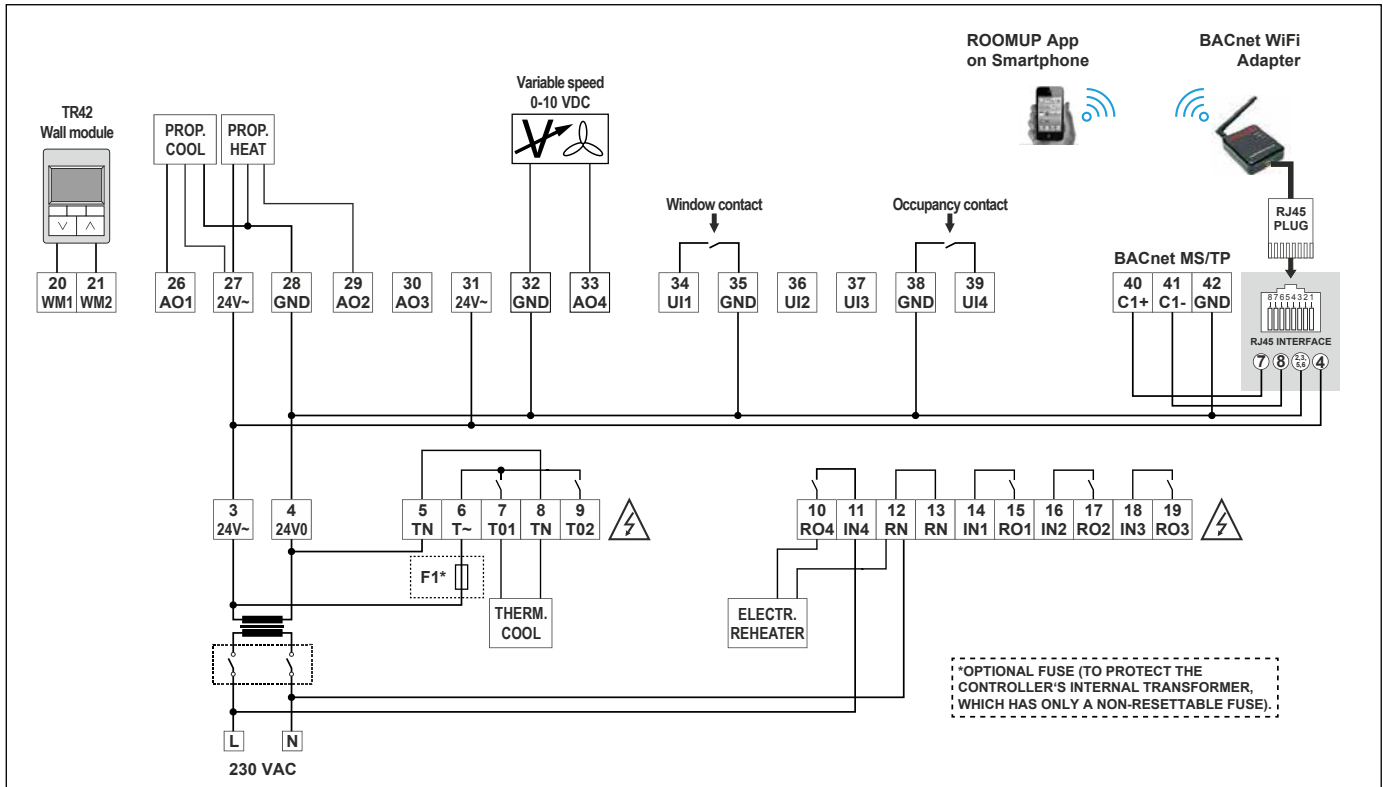

Fig. 7. PCD7.LRS5 example wiring

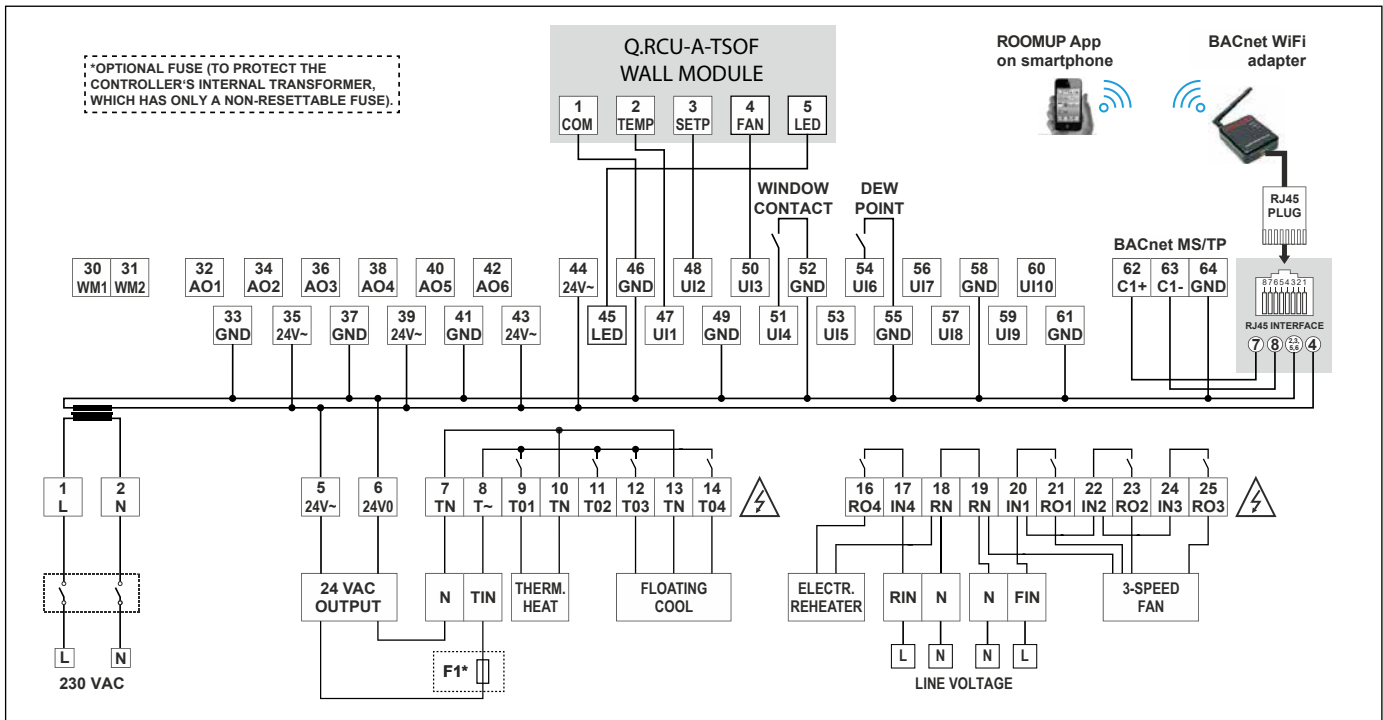

Fig. 8. PCD7.LRL2 example wiring

ELECTRICAL DATA

RL2 and RS4 (230 VAC)

Power via terminals 1 + 2: 230 VAC +10% / -15%, 50/60 Hz.

Max. power consumption (when unloaded): 8 W.

Max. power consumption (when loaded): 18 W.

The controller is "unloaded" when it has no external load. Thus, the only load on the controller is the inherent load (8 W) of the electronics, themselves. The heat dissipation then amounts to 8 W. The controller is "loaded" when – besides the inherent load – an additional sum load of max. **300 mA** is applied to the 24 VAC output terminals.

The max. unloaded output voltage at terminals 3 and 4 is 33 VAC (typically 29.5 VAC).

RS5 (24 VAC)

Power via terminals 3+4: 24 VAC ±20%, 50/60 Hz.

Max. current consumption (when unloaded): 300 mA.

Max. current consumption (when loaded): 900 mA.

The controller is "unloaded" when it has no external load. The heat dissipation then amounts to 7 W. The controller is "loaded" when – besides the inherent load (300 mA) – an additional sum load of max. **600 mA** is applied to the 24 VAC output terminals.

COMMISSIONING

Configurable Application

All models are delivered with the configurable application already included in the controller.

The configurable application has the advantage that it is proven and quickly commissioned using the ROOMUP commissioning tool available in the Google Playstore (URL: <https://play.google.com/store>) running on an Android Smart device with Android Version > V4.4. To activate the downloaded RoomUp app, it need to be ordered a RoomUp Licence-Key with ordering number PCD7.L-ROOMUP.

NOTE: Before configuring, if as yet no WLAN is present, the commissioning engineer will require a BACnet WiFi Adapter (order no.: BACA-A) to establish wireless communication between his Android Smart device and the controller.

Example Application Types

The configurable application supports the following application types:

- ▶ The **FCU application type** supports 1-, 2-, and 3-stage or variable-speed fan. It also supports water cooling, water heating (2-pipe or 4-pipe), electric re-heating, and dx-cooling (incl. fan interlock). It supports PID and, optionally, cascade control as well as min. temperature limitation. This application type may be used in combination with other types (see following).
- ▶ The **chilled/heated ceiling application type** uses PID with dewpoint protection (2-pipe or 4-pipe). It also supports 6-way valve on AO.
- ▶ The **radiator heating** application type uses PID and, optionally, min. temperature limitation.
- ▶ The **underfloor heating** application type uses PID and, optionally, max. temperature limitation.
- ▶ The **intake air** application type uses PID and, optionally, min. temperature limitation and air quality control.
- ▶ Those inputs/outputs not needed by the configurable application are available for use as free I/Os (like the I/Os of an I/O module) by the plant controller – see also PCD7.LRxx Room Controller – Installation & Commissioning Instructions (PP31-401).
- ▶ The use of different application types is limited by the number of I/Os supported by the given model.

Supported Actuators

The application supports a variety of actuators.

Table 6. Supported actuators

Supported actuators / Application	Analog 0(2)...10V	Floating	PWM	Stage 1	Stage 2, Stage 1+2	6-way valve 0...10V	ON / OFF
FCU Cooling	×	×	×	---	---	---	---
FCU Heating	×	×	×	---	---	---	---
FCU DX-Cooling	---	---	×	×	×	---	---
FCU E-Heating	---	---	×	×	×	---	---
Ceiling Cooling	×	×	×	---	---	×	---
Ceiling Heating	×	×	×	---	---	×	---
Ceiling Switch over 2-way Cooling	---	---	---	---	---	---	×
Ceiling Switch over 2-way Heating	---	---	---	---	---	---	×
Ceiling Switch over 3-way	---	---	---	---	---	---	×
Radiator Heating	×	×	×	---	---	---	---
Underfloor Heating	×	×	×	---	---	---	---
Intake Air	×	×	---	×	---	---	---
FreeAO	×	×	×	×	×	---	---
FreeBO	---	---	---	---	---	---	×

Supported Sensors

A variety of sensors (e.g., room temperature sensors, supply temperature sensors, condensation switch, window sensors, occupancy sensors, and card readers, etc.) may be used to optimize control quality.

Supported Operating Modes

The application supports a variety of different operating modes (e.g., occupied, standby, unoccupied, building protection, fan automatic/manual).

Automatic MAC Addressing

In contrast to many other MS/TP controllers, PCD7.LRxx BACNET Room Controllers features automatic MAC addressing. There is thus no need to manually set the MAC address.

BACnet MS/TP Master/Slave Functionality

During configuration, the commissioning engineer can identify (e.g., using the ROOMUP configuration tool) which of the controllers located on a given BACnet MS/TP bus are so-called "Masters," and which are so-called "Slaves." The commissioning engineer is not allowed to assign more than a single Master to each Slave; this is the only action which the commissioning engineer is required to perform. The Slave controller will inform its Master that it has been assigned to be its Slave.

The given application in the Master controller defines how this group (consisting of the Master controller and its Slave controllers) reacts to sensor inputs.

Examples:

- ▶ Activation of a window contact (indicating an opened window) will cause the application to stop heating/cooling.
- ▶ Each Master and each Slave needs to have its own ceiling cold water temperature sensor and its own condensation contact.
- ▶ Receipt of a condensation signal will stop cooling.
- ▶ Occupancy will be detected if one of the occupancy sensors detects occupancy.
- ▶ A key card will be detected if one of the key card sensors detects a key card.
- ▶ Occupancy override from one of the connected wall modules will trigger an occupancy override.
- ▶ The last setpoint change (temperature setpoint or fan speed setpoint) on one of the wall modules (TR40x / TR42x) will define the setpoint (NOTE: All TR42x wall modules will show the actual settings used by the controllers).
- ▶ For such sensor values as temperature, CO₂, and humidity, the average value is used (thus improving system robustness against failures of a single sensor and having a better average value of the room.)
- ▶ The Master shares schedule, heat/cool mode, actuator positions, etc. with its Slave(s).

OPERATOR INTERFACES LEDs

The controller features the following LEDs:



Fig. 10. Controller LEDs

Table 7. Description of LED behaviors

symbol	color	function, description
T2	yellow	Not used
R2	yellow	Not used
T1	yellow	LED indicating transmission of communication signals via the BACnet MS/TP interface
R1	yellow	LED indicating reception of communication signals via the BACnet MS/TP interface.
	yellow	Status LED indicating firmware problems, hardware problems, etc.
	green	Power LED indicating firmware problems, hardware problems, etc.
	red	Not used

Service Button

The controller's Service Button is used to trigger dedicated events.

COMMUNICATION INTERFACES

BACnet MS/TP Interface

The controller features an RS-485 interface (RLx: terminals 62, 63, and 64; RSx: terminals 40, 41, and 42) suitable for BACnet MS/TP communication. The terminal block containing it is black. The cable length affects the baud rate. See Table 8.

Table 8. Baud rate vs. max. cable length

baud rate	max. cable length (L)
9.6, 19.2, 38.4, 57.6, and 76.8 kbps	1200 m
115.2 kbps	800 m

For information on wire gauge, max. permissible cable length, possible shielding and grounding requirements, and the max. number of devices which can be connected to a bus, refer to standard EIA-485.

RJ-45 Connector for BACnet WiFi Adapter

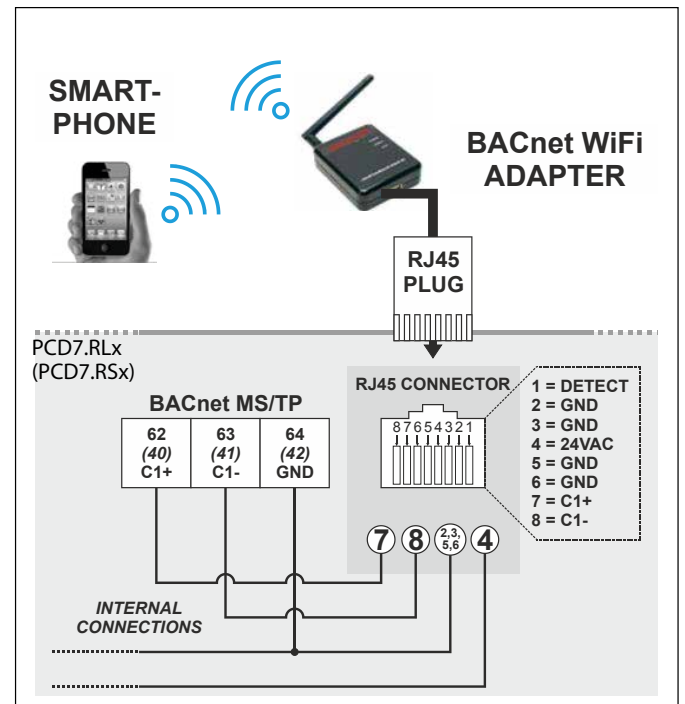

Fig. 11. RJ-45 interface and BACnet WiFi Adapter

CAUTION

It is permitted to connect **only** the BACnet WiFi Adapter to this RJ-45 connector. Do **not** connect IP!

A BACnet WiFi Adapter can be connected to the controller's RJ-45 connector in order to establish wireless communication with an Android Smart device so that the application engineer can configure the controller (using the ROOMUP configuration tool).

NOTE: When the BACnet WiFi Adapter is connected to the controller's RJ-45 connection, it is powered by the controller. It is then prohibited to simultaneously power the BACnet WiFi Adapter via a wall adapter.

When, on the other hand, the BACnet WiFi Adapter is instead connected to the controller's BACnet MS/TP interface, it is prohibited to simultaneously use an RJ-45 plug; instead, the BACnet WiFi Adapter must then be powered by a wall adapter (standard 5-V USB wall adapter with micro USB connector).

Wall Modules

The TR40, TR40-CO2, TR42, TR42-CO2 and PCD7.L63x, Q.RCU-A-Txxx and T7460x Wall Modules can be used in conjunction with the controller to perform room temperature sensing, setpoint adjustment, fan speed manual override, and occupancy override.

I/O TERMINALS

Relay Outputs

CAUTION

Mixing of different voltages (e.g., 24 V and 230 V) within the relay block is not allowed.

The terminal blocks containing the controller's relay outputs are orange. Relay output types: **See table 3**

NOTE: If inductive components are to be connected to the relays and if these relays switch more often than once every two minutes, these components must be prevented from causing harmful interference to radio or television reception (conformance with EN 45014).

Triac Outputs

NOTE: Recommended fuse (F1): 1.25 A time-lag fuse (IEC). User must consider the correct voltage and max. breaking capacity / interrupting rate (line voltage urgently requires high breaking capacity / interrupting rate).

The terminal blocks containing the controller's triac outputs are orange.

These triac outputs can be configured (using, e.g., the ROOMUP configuration tool) for a variety of different functions, e.g., for connection to either a floating drive or to a thermal actuator. Once the triac outputs have been configured, the corresponding devices can then be connected to them directly.

NOTE: The VC6983 actuator is intended for use at relay outputs, only and must not be used at the controller's triac outputs.

Triac Current Limitations

In the case of the 230-VAC versions of the controller, when the triacs are to be supplied with 24-VAC power from the controller's internal transformer, then the following applies:

- ▶ 300 mA max., i.e., a max. of one thermal actuator for heating and one thermal actuator for cooling can be operated (provided that heating and cooling are not operated at the same time).

CAUTION

The max. permissible power output of all 24 VAC terminals combined is 300 mA! If the triacs, alone, are loaded with 300 mA, then it is not permitted to connect a load at any other 24 VAC output terminal.

In all other cases, when the triacs are to be supplied with power (24 VAC or 230 VAC) from an external source, then the following applies:

- ▶ 700 mA (peak) and 600 mA (max.), i.e., two to three thermal actuators can be operated in parallel (depending upon the current consumption of the given actuator).

Universal Inputs

The terminal blocks containing the controller's universal inputs are blue. Universal input types: **See Table 3**.

The universal inputs are protected against voltages of max. 29 VAC and 30 VDC (due to, e.g., miswiring).

Bias Resistors

Each universal input is equipped with one bias resistor.

Analog Outputs

The terminal blocks containing the controller's analog outputs are green. Analog output types: **See Table 4**.

The analog outputs of the RLxx controllers (large housing) are protected against voltages of max. 29 VAC and 30 VDC (due to, e.g., miswiring).

NOTE: Connecting 24 VAC to any analog output of the RSxx controller (small housing) will damage the hardware.

TROUBLESHOOTING

The controller features the following LEDs:



Fig. 12. Controller LEDs

Table 9. Description of LED behaviors



symbol	color	function, description
T2	yellow	Not used
R2	yellow	Not used
T1	yellow	LED indicating transmission of communication signals via the BACnet MS/TP interface
R1	yellow	LED indicating reception of communication signals via the BACnet MS/TP interface.
	yellow	Status LED indicating firmware problems, hardware problems, etc. (see Table 9)
	green	Power LED indicating firmware problems, hardware problems, etc. (see Table 9)
	red	Watchdog (RL7U, only) has locked controller (see Table 9)

Table 10. Status LED and power LED behaviors

#	Mode	Power LED (green)	Status LED (yellow)
1	Power failure	Stays OFF	Stays OFF
2	Normal operation	ON/OFF (0.5 Hz)	Stays OFF
3	No firmware	ON/OFF (0.5 Hz)	ON/OFF (1 Hz)
4	No valid MAC	ON/OFF (0.5 Hz)	ON/OFF (0.5 Hz)
5	Auto-MAC	ON/OFF (1 Hz)	ON/OFF (0.5 Hz)
6	No application	ON/OFF (0.5 Hz)	ON/OFF (0.25 Hz)
7	Short-circuiting	ON/OFF (0.5 Hz)	Stays ON
8	Broken sensor	ON/OFF (0.25 Hz)	Stays ON
9	Watchdog locked	Turns ON and stays	Stays OFF
10	Device error*	Stays ON	Stays ON

* Please return the controller for repair (all of the software is missing).

ACCESSORIES

Terminal Protection Cover

Required for wall mounting. Bulk pack, set of ten covers.

- ▶ For LARGE controllers, order no.: **IRM-RLC**
- ▶ For SMALL controller, order no.: **IRM-RSC**

APPROVALS, CERTIFICATIONS, AND STANDARDS

Approvals and Certifications

- ▶ UL 60730-1, Standard for Automatic Electric Controls for Household and Similar Use, Part 1: General Requirements;
- ▶ CAN/CSA-E60730-1:02, Standard for Automatic Electrical Controls for Household and Similar Use, Part 1: General Requirements;
- ▶ Complementary listing for UL916, CSA C22.2 No. 205;
- ▶ BTL-listed, BACnet AAC profile;
- ▶ SASO-approved;
- ▶ CE-approved;
- ▶ FCC part 15B-compliant.

Classification according to EN 60730-1

EN 60730 sub part	EN 60730-2-9
Environmental conditions	For use in home (residential, commercial, and light-industrial) environments
Construction	Independently mounted electronic control unit with fixed wiring; panel-mounted on DIN rail
Action:	type 1.C
Rated impulse voltage	230 V circuits: 2500 V
24 V circuits	500 V
Pollution degree	2
Protection against shock	Class 0 (without terminal cover) Class II (with terminal cover)
Software class	A

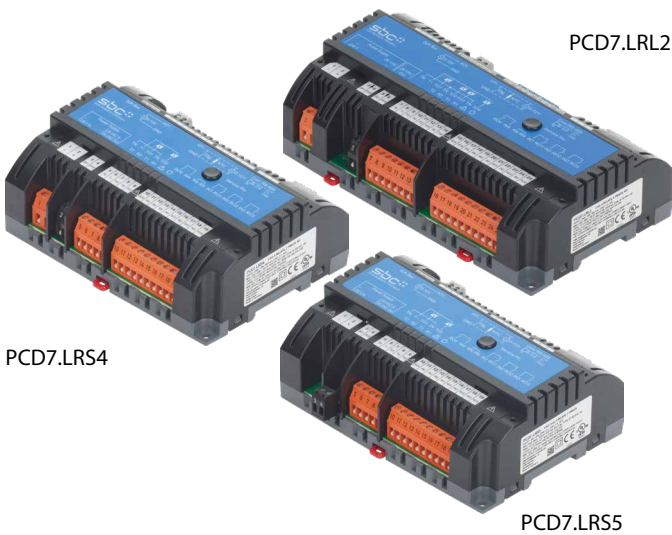

Fig. 23.
PCD7.LRxx without optional covers

Classification according to EN 60529

(Degree of protection provided by enclosures) IP20. In the case of controllers mounted outside of a cabinet, before applying power to the device, Terminal Protection Covers (10-pc. bulk packs, order no.: IRM-RLC for large housings and IRM-RSC for small housings) must be mounted so as to provide IP30.

Ambient Environmental Limits

5...95% r.H., non-condensing

Operating temperature (floor/ceiling mounting): 0...40 °C
 Operating temperature (wall/rail mounting): 0...50 °C
 Storage temperature: -20...70 °C

Trademark Information

BACnet™ is a trademark of ASHRAE Inc.

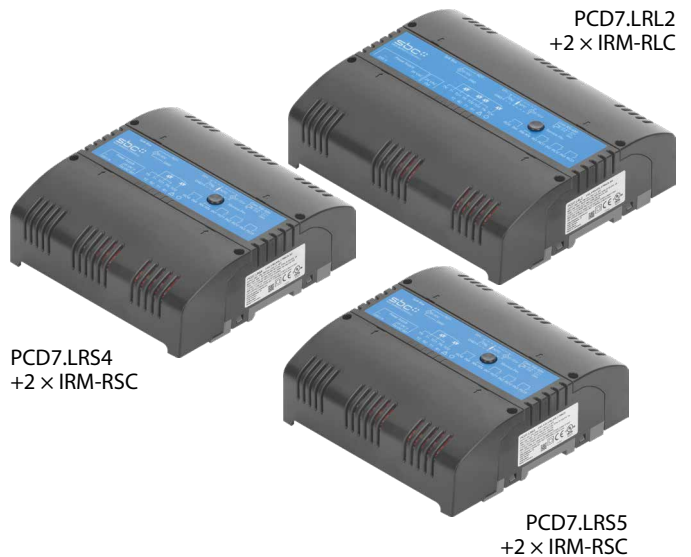

Fig. 24.
PCD7.LRxx with optional covers (covers come in sets of 10)

Saia-Burgess Controls AG
 Bahnhofstrasse 18
 3280 Murten
 Switzerland
 T +41 26 580 30 00
 F +41 26 580 34 99
 www.saia-pcd.com

info.ch@saia-pcd.com
 www.sbc-support.com

